



CATALOGO TECNICO TECHNICAL CATALOGUE

SISTEMI ANTINCENDIO UNI EN 12845 UNI EN 12845 FIRE FIGHTING SYSTEMS

SAFETY
EVERYWHERE.





www.idrofogliasafety.com

Indice Index

Introduzione / Introduction	4
Normativa UNI EN 12845 / Norm UNI EN 12845	6
Quadri Automatici / Control Panel	8
BG Base Giunto / BG Base Coupling	13
Voce di capitolato / Project description	14
Prestazioni pompe / Pumps performances	16
Idrofire BG P1E	19
Idrofire BG P2E	25
Idrofire BG ETP	31
Idrofire BG P1M	37
Idrofire BG PEM	43
Idrofire BG MTP	49
VTS Vertical Turbine / VTS Vertical Turbine	55
Voce di capitolato / Project description	56
Prestazioni pompe / Pumps performances	58
Idrofire VTS P1E	60
Idrofire VTS P2E	64
Idrofire VTS P1M	68
Idrofire VTS PEM	72
Idrofire VTS P2M	76
SM Sommerse / SM Submersible	80
Voce di capitolato / Project description	81
Prestazioni pompe / Pumps performances	82
Idrofire SM P1E	84
Idrofire VTS P2E	86
Accessori / Accessories	88
Informazioni tecniche / Technical information	93
Componenti per impianti / Components for installation	96



Idrofoglia Safety Systems

è una realtà giovane e dinamica specializzata nella progettazione e produzione di sistemi antincendio e pressurizzazione idrica civile/ industriale. La voglia di imporsi unita alla solida esperienza maturata dai suoi fondatori in più di trent'anni di attività nel settore del trattamento delle acque, fanno di Idrofoglia Safety Systems un partner capace ed affidabile. Il nostro obiettivo è la soddisfazione totale della clientela attraverso una costante innovazione dei nostri prodotti e servizi. Idrofoglia Safety Systems è partner attivo nell'interpretazione e anticipazione dei bisogni dei propri clienti e grazie a tecnologie all'avanguardia ed un team di professionisti.

Idrofoglia Safety Systems

is a young and dynamic company specialized in the project and manufacturing of fire fighting systems and hydro and civil pressurisation units. Idrofoglia Safety System is a safe and reliable partner thanks to its will to stand our and the solid experience of the founders that have been working for more than 30 years in the water treatment sector. Our aim is to totally satisfy the customers through a constant innovation of our products and services. We're always at our clients' disposal in order to anticipate and understand their needs thanks to technologies always at the forefront and to our highly specialized staff.

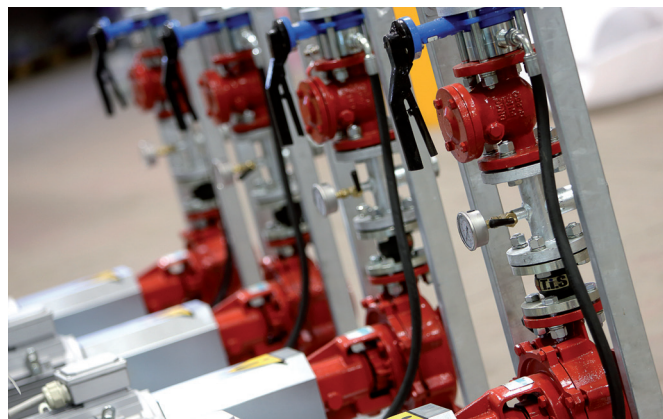
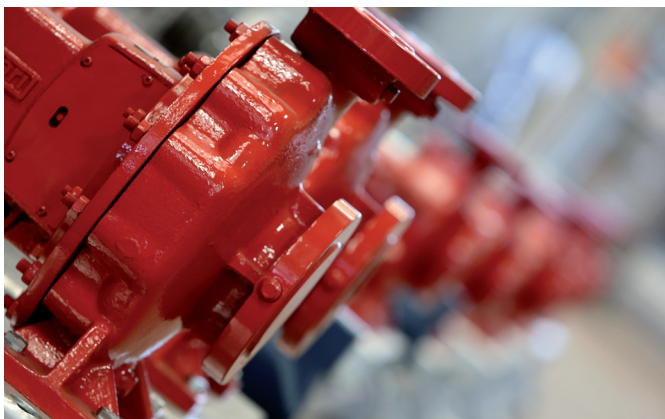

Idrofoglia Safety Systems

È il partner ideale per tutte le soluzioni di sistemi antincendio e pressurizzazione civile ed industriale.

SISTEMI ANTINCENDIO

Per i sistemi antincendio, Idrofoglia Safety Systems propone una vasta gamma di:

- Gruppi antincendio costruiti secondo le normative EN12845-UNI10779 con pompe del tipo base-giunto, con pompe verticali a stelo immerso e motore esterno (vertical turbine) e con elettropompe sommerse;
- Gruppi antincendio costruiti secondo le normative NFPA con pompe del tipo split case e pompe verticali a stelo immerso e motore esterno (vertical turbine);
- Locali per l'alloggiamento esterno dei gruppi di pompaggio, costruiti secondo normativa UNI11292;
- Serbatoi di riserva idrica in acciaio ed in polietilene da interro e da esterno;
- Sistemi integrati in acciaio da interro e da esterno, costruiti secondo normativa UNI11292.

In gamma, Idrofoglia Safety Systems propone anche:

- Sistemi di spegnimento a gas
- Sistemi water mist
- Materiali per reti idranti e reti sprinkler

SISTEMI DI PRESSURIZZAZIONE

Per i sistemi di pressurizzazione civile ed industriale, Idrofoglia Safety Systems propone una vasta gamma di:

- Gruppi di pressurizzazione a 2,3 o 4 elettropompe ad asse verticale od orizzontale comandate da quadro a pressostati;
- Gruppi di pressurizzazione a 2,3 o 4 elettropompe ad asse verticale od orizzontale comandate da inverter (nelle versioni a quadro, a bordo motore o a passaggio d'acqua);
- Serbatoi autoclave
- Sistemi di sollevamento per acque chiare o acque luride con elettropompe sommergibili e serbatoi in polietilene

Idrofoglia Safety Systems è in grado di offrire la soluzione più idonea a seconda delle applicazioni con sistemi che rispettano in pieno le normative vigenti. L'alta qualità dei prodotti è garantita dall'utilizzo di soli materiali di primaria marca e da un accurato collaudo effettuato da personale specializzato in apposito laboratorio. La realizzazione interna ed un elevato magazzino di tutte le componenti, assicurano consegne rapide, prezzi altamente competitivi e la possibilità di customizzare i nostri prodotti secondo le più svariate esigenze del cliente.



Is your ideal partner for all the solutions of fire fighting units and civil and industrial pressurisation.

FIRE FIGHTING UNITS

As for fire fighting units, Idrofoglia Safety Systems offer a wide range of:

- Fire fighting units according to EN12845-UNI10779 norms with base frame and coupling pumps, with vertical pumps and external engine (vertical turbine) and with submersible electro pump;
- Fire fighting unit according to NFPA norms with split case pumps and vertical pumps and external engine (vertical turbine);
- External room to the put pumping sets, manufactured according to UNI11292 norm.
- Steel and polyethylene water storage to be put underground and externally.
- Steel integrated systems to be put underground and externally, manufactured according to UNI11292 norm.

To complete the range Idrofoglia Safety Systems offer also:

- Gas extinguishing systems
- Water mist systems
- Hydrant networks and sprinkler networks materials

PRESSURIZATION SYSTEMS

Idrofoglia Safety System can offer you a wide range of civil and industrial pressurisation systems:

- Pressurisation units with 2,3 o 4 electro pumps with vertical and horizontal axle managed by 4 pressure switch.
- Pressurisation units with 2,3 o 4 electro pumps with vertical and horizontal axle managed by inverter (with panel, engine on board and water passage version).
- Autoclave tank.
- Lifting system for clean and dirty water with submersible electro pump and polyethylene tank.

Idrofoglia Safety Systems can offer you the most suitable solution with systems that totally respect the norms in force.

The high quality of the products is granted by the use of first choice materials and of an accurate test made by our highly specialized staff in an appropriate workshop. The fact that we have a huge stock of all the components and that we manufacture everything inside our premises assure fast deliveries, very competitive prices and the possibility to customize our products following customers needs.



PRINCIPALI INFORMAZIONI SULLA NORMATIVA UNI EN 12845

La normativa

La normativa UNI EN 12845 "Impianti fissi di estinzione incendi - Sistemi automatici sprinkler - Progettazione, installazione e manutenzione", valida per tutta la UE, regolamenta l'esecuzione degli impianti antincendio utilizzando sprinkler e sistemi di pompaggio acqua ad uso antincendio adatti all'alimentazione di reti idriche antincendio sprinkler o idranti.

Principio di funzionamento

I sistemi antincendio IDRO J-FIRE sono realizzati in conformità alle normative UNI EN 12845.

Sono composti da una o più pompe principali da motori elettrici o diesel e da una pompa di compensazione (pompa pilota), che ha la funzione di mantenere in pressione l'impianto, oltre che compensare le piccole perdite nell'impianto stesso, evitando inopportuni avviamenti delle pompe principali (EN 12845:2009 punto 3.49 e par. 10.6.2.5).

La logica di funzionamento conforme alla normativa EN12845 prevede che le pompe entrino in funzione automaticamente in seguito ad una caduta di pressione dell'impianto e vengano arrestate manualmente.

In caso di una richiesta d'acqua dall'impianto, la prima a partire è la pompa di compensazione; se questa non riesce a ristabilire la pressione, interviene la pompa principale. Nel caso di più pompe, se la pressione nell'impianto continua a scendere, entrerà in funzione automaticamente anche la pompa di riserva indipendentemente dal funzionamento della pompa principale.

Per gli impianti ad idranti, ove ritenuto necessario per attività non costantemente presidiate, è ammesso anche l'arresto automatico del sistema, dopo che la pressione sia mantenuta costante per 20 minuti consecutivi (UNI10779 Appendice A.1.2).

COME RICONOSCERE SE UN GRUPPO ANTINCENDIO RISPETTA LA NORMATIVA DI RIFERIMENTO EN12845 PUNTI PRINCIPALI:

Dimensionamento e alimentazioni

- Dimensionamento dei motori (elettrico e Diesel) della pompa principale in corrispondenza dell'assorbimento ad NPSH 16 m della pompa stessa (Par. 10.1); consigliamo di richiedere le curve prestazionali complete della curva di assorbimento della pompa ad NPSH 16 m;
- In caso di pompe orizzontali deve essere possibile intervenire indipendentemente sia sul motore che sulla pompa ed eseguire le operazioni di manutenzione sulla pompa senza intervenire sulle tubazioni. Le pompe di aspirazione assiale devono essere del tipo back pull-out, (smontaggio lato motore). (Par. 10.1)
- Nei casi in cui più di una pompa è installata in una alimentazione idrica superiore o multipla, solamente una deve essere azionata da un motore elettrico (Par. 10.2);

In caso di motopompa

- Il motore Diesel deve essere in grado di funzionare continuamente a pieno carico alla quota di installazione con una potenza nominale continua e deve essere in grado di rendere operativa la pompa entro 15 secondi dall'inizio della sequenza di avviamento (Par. 10.9.1)
- Il serbatoio del combustibile deve contenere una quantità sufficiente di combustibile in grado di far funzionare il motore a pieno carico per 3,4 o 6 ore in base alla classificazione di rischio incendio dello stabile (Par. 10.9.6);
- Ogni motopompa deve essere collaudata dal fornitore per almeno 1,5 h alla portata nominale riportando tutti i dati di portata, prevalenza, velocità e temperature su apposito certificato (Par. 10.9.13.1);
- Il sistema di avviamento del motore deve essere dotato di due batterie separate, ogni batteria deve essere dotata di un carica batteria indipendente, sempre collegato alla rete (Par. 10.9.8 e Par. 10.9.9).

Circuito di avviamento pompe

- Ogni pompa di servizio deve essere munita di un circuito composto da due pressostati, (uno di riserva all'altro in caso di anomalie), (Par. 10.7.5.1 – 10.7.5.3)

Componentistica di mandata (Par. 10.5)

- Su ogni pompa è necessario installare una valvola di non ritorno e una valvola di intercettazione
- Ogni pompa, se necessario per garantire una velocità inferiore ai 6 m/s (Par. 13.2.3), deve prevedere in mandata un cono concertino con angolo non superiore a 20°; il ns. cono concentrico ha anche la predisposizione per l'attacco al circuito di adescamento in caso di installazione soprabattente
- Tutte le valvole in mandata devono essere installate dopo una qualsiasi tubazione conica.
- Ogni pompa deve prevedere un dispositivo di ricircolo per assicurare un flusso continuo di acqua attraverso la pompa sufficiente a prevenire il surriscaldamento in caso di funzionamento a mandata chiusa.

Componentistica di aspirazione (10.6.2)

- Ogni pompa deve prevedere in aspirazione un cono eccentrico con lunghezza pari ad almeno 2 volte il diametro, con la parte superiore rettilinea ed una conicità che non superi i 20°.
- Le valvole non possono essere installate direttamente sull'aspirazione della pompa. (Par.10.6.2.1)

In caso di aspirazione SOTTOBATTENTE (Par 10.6.2.2)

- La tubazione in aspirazione sarà dimensionata in maniera tale da garantire una velocità in aspirazione inferiore a 1,8 m/s alla massima portata richiesta, considerando che il diametro minimo della tubazione in aspirazione non deve essere inferiore a 65 mm;
- Nel caso di più pompe le aspirazioni possono essere interconnesse, se dotate di una valvola di intercettazione.
- È consigliato per una corretta installazione installare sempre una valvola di intercettazione, su ogni pompa, per gli interventi di manutenzione ed un giunto in gomma per attutire le vibrazioni in aspirazione (obbligatorio per la motopompa)

In caso di aspirazione SOPRABATTENTE(Par 10.6.2.3)

- La tubazione in aspirazione sarà dimensionata in maniera tale da garantire una velocità in aspirazione inferiore a 1,5 m/s alla massima portata richiesta, considerando che il diametro minimo della tubazione in aspirazione non deve essere inferiore a 80 mm;
- L'altezza del livello minimo dell'acqua non può superare i 3,2 m;
- Nel caso di più pompe le aspirazioni devono essere separate, anche l'aspirazione della pompa di compensazione (Par 10.6.2.5);
- È necessario installare nel punto più basso una valvola di fondo e prevedere un dispositivo di adescamento automatico separato per ogni pompa.

Il dispositivo deve comprendere un serbatoio della capacità di 100 o 500 l (in base alla classificazione di rischio incendio dello stabile) posizionato ad un livello più alto rispetto alla pompa e con una tubazione di collegamento discendente dal serbatoio alla mandata della pompa.

Il serbatoio e l'aspirazione della pompa devono essere mantenute costantemente piene d'acqua, se il livello del serbatoio scende sotto i 2/3 la pompa deve partire.

Il serbatoio deve essere fornito di tutto ciò che viene richiesto dal paragrafo 10.6.2.4 Fig. 6

MAIN INFORMATIONS ABOUT THE UNI EN 12845 NORM

EN 12845 Standard

The EN 12845 rule "Fixed fire fighting installations – Sprinkler automatic system – Planning installations and maintenance" is compulsory in all EU countries. The norm regulate the implementation of the fire fighting systems using sprinkler and pumping water system for fire fighting use appropriate to the fire fighting water supply network sprinkler or hydrant.

Working Principle

The fire fighting systems IDRO J-FIRE are realized according to the EN 12845 norm. Composed by one or more main pumps, electric or diesel motors and one jockey pump used to keeps the fire fighting circuit pressurized as well as to replenish minor water loss to avoid starting an automatic suction or booster pump unnecessarily.

The jockey pump is automatically started and stopped by means of a pressure switch and keeps the fire fighting circuit pressurized. The main pump and the standby pump will start in sequence if there is a pressure drop in the circuit that cannot be compensated by the limited flow rate of the jockey electric pump.

The main pump and the standby pump will start automatically but are stopped in the manual mode with a switch on the relative control panel.

If the over pressure system is to exclusive service of an hydrant net, for not constantly protected activities, the stop can happen automatically, after that the pressure has been constantly maintained over the starting pressure of the pump at least 20 minutes in succession.

HOW TO RECOGNIZE IF A FIRE FIGHTING UNIT IS MANUFACTURED ACCORDING TO THE EN12845 NORM

HIGHLIGHTS:

Sizing and power supply

- For pumps with increasing power characteristics, motor (electric and diesel) must be able to supply the maximum in any charge situation of the pump, from invalid capacity to the capacity at NPSH 16 (Sec. 10.1); we suggest to request the performance curve complete with the absorption curve of the pump at NPSH16;
- In case of horizontal pumps the coupling between the driver and the pump shall be of a type which ensures that either can be removed independently and in a such a way that pump internals can be inspected or replaced without affecting suction or discharge piping. End suction pump shall be of the "back-pull out" type (Sec 10.1)
- Where more than one pump is installed in a superior or duplicate water supply, no more than one shall be driven by an electric motor (Sec. 10.2)

In case of diesel engine

- The diesel engine shall be capable of operating continuously at full load at site elevation with a rated continuous power output (according to ISO 3046). The diesel engine has also to guarantee that the pump has to be fully operational within 15s of the beginning of any starting sequence (Sec. 10.9.1)
- The fuel tank shall contain sufficient fuel to enable the engine to run on full load for 3-4-6 hours depending on the risk class of the system (Sec. 10.9.6);
- Each complete engine and pump-set shall be tested by the supplier for no less than 1,5 h at the rated flow. All the parameters contained in Sec. 10.9.13.1 (flow rate, hydraulic head, temperatures, engine speed...) has to be mentioned on the test certificate (Sec. 10.9.13.1);
- The starting system of the diesel engine has to be fitted out with two separate battery power suppliers. Each starter battery shall be provided with an independent, continuously connected, fully automatic and constant potential charger. It shall be possible to remove either charger while leaving the other operational (Sec. 10.9.8 – Sec. 10.9.9)

Pump starting circuit

- Two pressure switches shall be provided to start each pump set in order to assure the work of each pump in case of anomalies. They must be connected in series with normally closed contact (Sec. 10.7.5.1 – 10.7.5.3).

Valves and accessories (sec. 10.5)

- A non-return and a stop valve shall be installed on each pump;
- Any taper pipe fitted to the pump outlet, if it is necessary to guarantee a lower water speed of 6 m/s (Sec. 13.2.3) shall expand in the direction of flow at an angle not exceeding 20°;
- Valves on the delivery side shall be fitted after any taper pipe;
- Some arrangements (e.g. circulation device) shall be made to ensure a continuous flow of water through the pump sufficient to prevent overheating when it is operating against a closed valve

Suction conditions (sec. 10.6.2)

- The pump suction shall be connected to a straight or taper pipe at least two diameters long. The taper pipe shall have an horizontal top side and a maximum included angle not exceeding 20°;
- Valves shall not be fitted directly to the pumps inlet (Sec. 10.6.2.1)

Positive head (10.6.2.2):

- In positive head conditions, the diameter of the suction pipe shall be no less than 65 mm. Furthermore, the diameter shall be such that a velocity of 1,8 m/s is not exceeded when the pump is operating at maximum demand flow. Where more than one pump is provided, the suction pipes may only be inter-connected if they are fitted with stop valves to allow each pump to continue operating when the other is removed for maintenance. The connections shall be dimensioned as appropriate for the flow rate required.
- It is recommended, for a correct installation, to install on each pump a stop valve for maintenance intervention, and a rubber joint to ease the suction vibration (compulsory in case of diesel engine pump)

Suction lift (sec. 10.6.2.3):

- In suction lift conditions, the diameter of the suction pipe shall be no less than 80 mm. Furthermore, the diameter shall be such that a velocity of 1,5 m/s is not exceeded when the pump is operating at maximum demand flow;
- The height from the low water level (see 9.3.5) to the centre line of the pump shall not exceed 3,2 m;
- Where there is more than one pump-set installed, the suction pipes shall not be interconnected;
- Each pump shall be fitted with a separate automatic priming arrangement. The arrangement shall consist of a tank of 100 or 500 lt. (depending on the risk class of the system) situated at a higher level than the pump and with a pipe connection sloping from the tank to the delivery side of the pump. A non-return valve shall be fitted to this connection. The tank, the pump and the suction pipework shall be kept constantly full of water. Should the water level in the tank fall to 2/3 of the normal level, the pump shall start. The tank shall be provided with everything requested by the Sec. 10.6.2.4 – Fig. 6.

ISG 100

Idrofoglia Safety Guard

QUADRO AUTOMATICO PER ELETTROPOMPA PILOTA

Avviamento Diretto

Costruito secondo normativa UNI EN12845

CONTROL PANE FOR JOCKEY ELECTRIC PUMP

Direct starting

Produced according to UNI EN12845

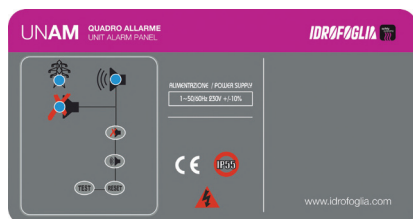

- Alimentazione 3 ~ 50/60Hz 400V±10%
- Quadro elettronico
- Ingresso normalmente aperto per comando di avviamento
- Ingresso per 3 sonde unipolari o galleggiante
- Pulsantiera per selezione funzionamento automatico, manuale (momentaneo), Spento/Reset
- Dip-switch per funzionamento sonde in Riempimento/Svuotamento
- Sensibilità sonde regolabile
- Led verde di presenza rete
- Led verde automatico inserito
- Led verde motore attivo
- Led rosso allarme livello
- Led rosso allarme motore in sovraccarico
- Controllo elettronico per sovraccarico motore regolabile
- Protezione ausiliari e motore con fusibili
- Uscita allarme (com-no-nc carico resistivo)
- Sezionatore generale bloccoporta
- Possibilità di inserimento condensatore di marcia (optional)
- Box in ABS, IP55
- Temperatura ambiente: -5/+40 °C
- Umidità relativa 50% a 40 °C (non condensata)
- Power supply 3~50/60 Hz 400V ±10%
- Electronic panel
- Normally open contact for start
- Contact for 3 level probes or float switch
- Push-buttons for selecting operation automatic, manual (temporary), Off/ Reset
- Dip-switch selector for filling/emptying operation
- Probes sensitivity adjustable
- Green led indicating mains supply
- Green led indicating automatic operation
- Green led indicating motor running
- Red led indicating level alarm
- Red led indicating motor overload
- Adjustable overload electronic protection
- Auxiliaries and motor protection fuses
- Alarm output (com-no-nc resistive load)
- Main switch interlocking door
- Running capacitor can be added (optional)
- Enclosure in ABS, IP55
- Ambient temperature: -5/+40 °C
- Relative humidity 50% at 40 °C (not condensed)

ISG 200 D

Idrofoglia Safety Guard

QUADRO AUTOMATICO PER ELETTROPOMPA DI SERVIZIO

Avviamento Diretto

Costruito secondo normativa UNI EN12845

CONTROL PANE FOR MAIN ELECTRIC PUMP

Direct starting

Produced according to UNI EN12845

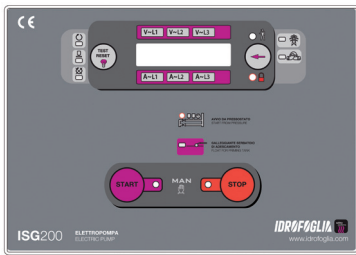

- Alimentazione 3 ~ 50/60Hz 400V±10%
- Ingressi e circuiti di comandi in bassa tensione
- N.2 Ingressi normalmente chiusi per pressostati di avviamento
- Ingresso per comando da serbatoio di avviamento
- Ingresso per segnalazione da pressostato impianto in pressione/pompa spenta
- Ingresso per segnalazione basso livello riserva idrica
- Selettore a chiave AUTO-0-EMERGENZA
- Pulsanti Marcia/Arresto per prova manuale
- Pulsante prova led centralina
- Display LCD per visualizzazione volt di rete e ampere su 3 fasi, Hz, var, watt, voltampere, cosfi, contaore totale e parziale, cronologia eventi
- Display con 5 lingue: Italiano, Inglese, Francese, Spagnolo, Tedesco
- Led di segnalazione
- Possibilità di funzionamento secondo UNI10779
- Funzioni di ritardo e allarmi impostabili
- Uscite allarme cumulativo di tipo A e tipo B
- Contattore elettropompa in AC4
- Protezione ausiliari e motore con fusibili
- Sezionatore generale bloccoporta
- Box metallico, IP55
- Temperatura ambiente: -5/+40 °C
- Umidità relativa 50% a 40 °C (non condensata)
- Power supply 3~50/60 Hz 400V ±10%
- Auxiliary circuits in low voltage
- N.2 Normally close contacts for start pressure switches
- Contact for contact from priming tank
- Contact for signal from pressure switch of system in pressure/pump off
- Contact for "low water mark" in to the water tank
- Key-selector for Auto-Off-Emergency
- Push-buttons for pump Start/Stop in manual test
- Push-buttons for checking the control unit's LED
- LCD for monitoring: mains volt and ampere on 3 phases, Hz, var, watt, voltampere, cosfi, total and partial hour meter , events chronology
- LCD in 5 languages: Italian, English, French, Spanish, German
- LED for signals
- Operation mode according to UNI10779
- Specific alarms and delays settable on the electronic unit
- Terminal cumulative A and B allarm
- Contactor in AC4
- Auxiliaries and motor protection fuses
- Main switch interlocking door
- Steel enclosure, IP55
- Ambient temperature: -5/+40 °C
- Relative humidity 50% at 40 °C (not condensed)

ISG 200 ST

Idrofoglia Safety Guard

QUADRO AUTOMATICO PER ELETTROPOMPA DI SERVIZIO

Avviamento Stella-Triangolo

Costruito secondo normativa UNI EN12845

CONTROL PANE FOR MAIN ELECTRIC PUMP

Star-Delta starting

Produced according to UNI EN12845

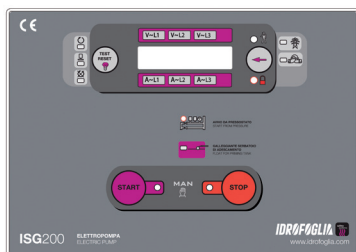

- Alimentazione 3 ~ 50/60Hz 400V±10%
- Ingressi e circuiti di comandi in bassa tensione
- N.2 Ingressi normalmente chiusi per comando pressostati di avviamento
- Ingresso per comando da serbatoio di adescamento
- Ingresso per segnalazione da pressostato impianto in pressione/pompa spenta
- Ingresso per segnalazione basso livello riserva idrica
- Selettore a chiave AUTO-0-EMERGENZA
- Pulsanti Marcia/Arresto per prova manuale
- Pulsante prova led centralina
- Pulsante menu funzioni centralina
- Display LCD per visualizzazione volt di rete e ampere su 3 fasi, Hz, var, watt, voltampere, cosfi, contaore totale e parziale, cronologia eventi
- Display con 5 lingue: Italiano, Inglese, Francese, Spagnolo, Tedesco
- Led di segnalazione
- Possibilità di funzionamento secondo UNI10779
- Funzioni di ritardo e allarmi impostabili
- Temporizzatore stella-triangolo regolabile da centralina
- Uscite allarme cumulativo di tipo A e tipo B
- Contattore elettropompa in AC4
- Protezione ausiliari e motore con fusibili
- Sezionatore generale bloccoporta
- Involucro metallico, IP55
- Temperatura ambiente: -5/+40 °C
- Umidità relativa 50% a 40 °C (non condensata)
- Power supply 3~50/60 Hz 400V ±10%
- Auxiliary circuits in low voltage
- N.2 Normally close contacts for start pressure switches
- Contact for signal from priming tank
- Contact for signal from pressure switch of system in pressure/pump off
- Contact for "low water mark" in to the water tank
- Key-selector for Auto-Off-Emergency
- Push-buttons for pump Start/Stop in manual test
- Push-buttons for checking the control unit's LED
- Push-buttons for checking the control unit's LED;
- LCD for monitoring: mains volt and ampere on 3 phases, Hz, var, watt, voltampere, cosfi, total and partial hour meter , events chronology
- LCD in 5 languages: Italian, English, French, Spanish, German
- LED for signals
- Operation mode according to UNI10779
- Specific alarms and delays settable on the electronic unit
- Star/delta timer adjustable on electronic unit
- Terminal cumulative A and B alarm
- Contactor in AC4
- Auxiliaries and motor protection fuses
- Main switch interlocking door
- Steel enclosure, IP55
- Ambient temperature: -5/+40 °C
- Relative humidity 50% at 40 °C (not condensed)

ISG 300

Idrofoglia Safety Guard

QUADRO AUTOMATICO PER MOTOPOMPA DIESEL

Costruito secondo normativa UNI EN12845

CONTROL PANE FOR MAIN DIESEL MOTOR PUMP

Produced according to UNI EN12845

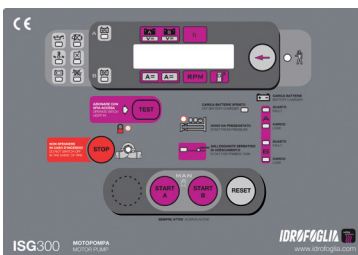

- Alimentazione 1 ~ 50/60Hz 230V±10%;
- Ingressi e circuiti di comandi in bassa tensione;
- N.2 Ingressi normalmente chiusi per comando pressostati di avviamento;
- N.2 Ingressi da batterie esterne per motorino d'avviamento ed alimentazione circuiti ausiliari;
- Ingresso per comando da serbatoio di adescamento;
- Ingresso per segnalazione da pressostato impianto in pressione/motopompa spenta;
- Ingresso per segnalazione basso livello riserva idrica;
- Selettore a chiave AUT-MAN;
- Pulsanti di avviamento e arresto manuale motopompa;
- Pulsante di ripristino anomalie;
- Pulsante prova avviamento manuale (attivo in caso di mancato avviamento automatico);
- Pulsante prova led centralina;
- Pulsanti di avviamento di Emergenza Manuale protetti da "Safe crash";
- Display LCD retroilluminato per visualizzazione n. 2 voltmetri batterie, n. 2 amperometri batterie, contagiri, contatore totale e parziale, indicatore livello combustibile, termometro acqua, termometro olio, manometro olio, contavviamenti da batterie e storico eventi;
- Led di segnalazione;
- Possibilità di funzionamento secondo UNI10779;
- Display con 5 lingue: Italiano, Inglese, Francese, Spagnolo, Tedesco;
- Funzioni di ritardo e allarmi impostabili;
- Uscite allarme cumulativo di tipo A e tipo B.
- N.2 caricabatteria 12Vdc 3A (24Vdc 3A per versione a 24V);
- Protezione ausiliari e motore con fusibili;
- Sezionatore generale bloccoporta;
- Involucro metallico, IP55;
- Temperatura ambiente: -5/+40 °C;
- Umidità relativa 50% a 40 °C (non condensata);

- Power supply 1~50/60 Hz 230V ±10%;
- Auxiliary circuits in low voltage;
- N.2 Normally close contacts for start pressure switches;
- N.2 Contacts from external batteries for starting motor and auxiliary circuits power supply;
- Contact for signal from priming tank;
- Contact for signal from pressure switch of system in pressure/pump off;
- Contact for "low water mark" in to the water tank
- Key-selector for AUT-MAN;
- Push-buttons for manual Start/Stop of the pump;
- Push-buttons for faults reset;
- Push-button for manual start test (active in case of auto-start failed);
- Push-buttons for checking the control unit's LED;
- Push-button for manual emergency start protected by "Safe crash";
- LCD for monitoring: n.2 batteries volt and ampere, round counter, total and partial hour counter, fuel level indicator, water and oil temperature, oil pressure, start counter and events chronology;
- LED for signals;
- Operation mode according to UNI10779;
- LCD in 5 languages: Italian, English, French, Spanish, German;
- Specific alarms and delays settable on the electronic unit;
- Terminal cumulative A and B allarm
- N.2 Battery chargers 12Vdc 3A (24Vdc 3A for 24V version);
- Auxiliaries and motor protection fuses;
- Main switch interlocking door;
- Steel enclosure, IP55;
- Ambient temperature: -5/+40 °C;
- Relative humidity 50% at 40 °C (not condensed).



GRUPPI ANTINCENDIO

GAMMA BG - VTS - SM

FIRE FIGHTING UNITS

BG - VTS - SM RANGE

GRUPPI ANTINCENDIO
BASE GIUNTO BG

EN 12845
UNI 10779

FIRE FIGHTING UNITS
BASE COUPLING BG



IDROFIRE BG P1E



IDROFIRE BG P2E



IDROFIRE BG ETP



IDROFIRE BG P1M



IDROFIRE BG PEM



IDROFIRE BG MTP

VOCE DI CAPITOLATO

Fornitura e posa in opera di gruppo di pressurizzazione antincendio, tipo IDROFOGLIA a norma EN12845 con pompe normalizzate base-giunto secondo EN733 (DIN 24255) accoppiate al motore mediante giunto elastico con distanziale, composto da:

Sezione Elettropompa pilota

n°1 elettropompa pilota, monoblocco autoadescente, per il mantenimento della pressione all'interno dell'anello antincendio, con bocca aspirante assiale e bocca premente radiale, entrambe filettate ISO 228/1, corpo pompa in ghisa, gruppo eiettore in tecnopolimero, albero in acciaio INOX, girante in ottone, tenuta in ceramica-grafite-NBR accoppiata con motore elettrico chiuso con ventilazione esterna trifase classe d'isolamento F e protezione IP44.

La pompa pilota è corredata in mandata di una valvola di ritegno, una valvola a sfera, un vaso di espansione 20 litri PN16, e raccordi per il collegamento al quadro di comando. La pompa è comandata in automatico da un quadro in lamiera zincata con applicato un pressostato di avviamento regolabile con grado di protezione IP55, manometro e circuito di prova del pressostato.

L'elettropompa pilota è comandata da un quadro di controllo indipendente costruito secondo norma EN12845, in lamiera verniciata con grado di protezione IP55 ad avviamento diretto, così composto:

- interruttore blocco porta fusibilitato
- contattore e relè termico
- selettore Manuale – 0 – Automatico a chiave
- lampada di avviamento
- lampada di blocco
- lampada di presenza rete
- trasformatore 400/24/12V per circuito ausiliario
- fusibili per circuito ausiliario
- morsettiera e pressacavi
- alimentazione 400 (3F) 50 Hz

Sezione Elettropompa di servizio (o di riserva)

n°1 elettropompa di servizio del tipo base giunto ad asse orizzontale, monogirante con bocca aspirante assiale e bocca premente radiale, entrambe flangiata UNI PN16, corpo pompa in ghisa, albero in acciaio inox e tenuta meccanica in grafite/carburo di silicio, accoppiate mediante giunto elastico con distanziale a un motore asincrono trifase in forma B3 a ventilazione esterna, classe d'isolamento F, sovratemperatura dell'avvolgimento classe B, grado di protezione IP 55, numero di giri 2900 g/min.

L'elettropompa di servizio è comandata da un quadro di controllo indipendente costruito secondo norma EN12845, in lamiera verniciata con grado di protezione IP55 ad avviamento diretto (fino a 9,2 kW) ed avviamento stella-triangolo (da 11 kW) così composto:

- interruttore blocco porta
- scheda elettronica di gestione programmabile con spie e led di segnalazione
- prova settimanale integrata
- presa interbloccata di servizio monofase 16 A
- selettore Manuale – 0 – Automatico a chiave
- pulsanti di marcia e arresto
- relè mancanza fase e sequenza fase
- batteria a tampone con carica batteria
- trasformatore 400/24/12V per circuiti ausiliari
- fusibili per circuito ausiliario
- fusibili generali
- n.3 contattori
- temporizzatore di scambio
- amperometro
- voltmetro con commutatore voltmetrico
- lampeggiante con avvisatore acustico
- morsettiera
- alimentazione 400 (3F+N) 50 Hz

Sezione Motopompa di servizio (o di riserva)

n°1 motopompa di servizio del tipo base giunto ad asse orizzontale, monogirante con bocca aspirante assiale e bocca premente radiale, entrambe flangiata UNI PN16, corpo pompa in ghisa, albero in acciaio inox e tenuta meccanica in grafite/carburo di silicio, accoppiate mediante giunto elastico con distanziale a un motore diesel raffreddato ad aria fino a 30 kW e a liquido al di sopra dei 30 kW, con cinghie multiple, completo di serbatoio a caduta per un'autonomia di 6 h e doppia batteria per l'avviamento. Il gruppo motopompa sarà completo di giunti antivibranti collegati al telaio e giunto di compensazione sull'aspirazione della pompa. La motopompa è comandata da un quadro di controllo indipendente costruito secondo norma EN12845, in lamiera verniciata con grado di protezione IP55 così composto:

- interruttore blocco porta
- scheda elettronica programmabile di comando e gestione motopompa
- indicazioni ed allarmi sul display
- selettore Manuale – 0 – Automatico a chiave
- n.2 carica batterie 12/24V con controllo a microprocessore completi di n.2 trasformatori 230/16V e circuiti separati per l'alimentazione
- controllo batterie sul display
- fusibili per circuito ausiliario
- contagiri analogico
- prova settimanale integrata
- magnetotermico differenziale preriscaldamento
- morsettiera
- alimentazione 230 (F+N) 50 Hz

Ogni pompa principale è corredata in aspirazione di un manovuotometro. La mandata della pompa è corredata in sequenza di un giunto in gomma di compensazione, un aumento flangiato per garantire una velocità dell'acqua pari a 6 m/s, predisposto per il collegamento del serbatoio di adescamento, un diaframma calibrato in ottone da 3/8" per il ricircolo e lo scarico dell'aria della pompa, un manometro, una valvola di non ritorno ispezionabile, un diaframma zincato con uscita da 1/2" per il collegamento al quadro di avviamento della pompa e una valvola a farfalla d'intercettazione. Le pompe sono comandate in automatico da un pannello di controllo in lamiera zincata, collegato al diaframma mediante un tubo RILSAN 2034 15/12.5 pa12, dove si trovano 2 pressostati di avviamento regolabili con grado di protezione IP55, manometro e circuito di prova dei pressostati.

Sul collettore di mandata vi è la predisposizione per il collettore di prova, il collettore è sorretto da 2 gambe collegate al telaio principale, per garantire la stabilità e la continuità del servizio anche se si interviene su di una pompa.

Quadri, pompe e motori sono installati su un telaio realizzato in acciaio zincato.

ACCESSORI A CORREDO:

• Kit Flussimetro adeguatamente dimensionato, composto da:

- Flussimetro a lettura rinviata
- Collettore in acciaio zincato
- Valvola di intercettazione

• Quadro allarme acustico-luminoso di remotazione allarme

• Per installazione del gruppo di tipo soprabattente, ogni singola pompa di servizio è corredata in aspirazione di una riduzione eccentrica flangiata (se necessario), per garantire una velocità dell'acqua in aspirazione pari a 1,5 m/s e viene mantenuta costantemente carica da un serbatoio di adescamento in LLDPE da 500 litri che dovrà essere collegato alla pompa di servizio mediante un tubo di diametro 50 mm; sul collegamento della pompa vi è applicata una valvola di ritegno. Il serbatoio è mantenuto pieno dalla rete idrica con applicata una valvola a galleggiante, se il livello del serbatoio, per eventuali perdite della valvola di fondo, scende sotto i 2/3 vi è un interruttore di livello che fa partire la pompa di servizio.

• Per installazione del gruppo di tipo sottobattente, ogni singola pompa di servizio è corredata in aspirazione di una riduzione eccentrica flangiata (se necessario), per garantire una velocità dell'acqua in aspirazione pari a 1,8 m/s e una valvola di intercettazione (valvola a farfalla "Lug") e la pompa pilota di valvola a sfera con giunto a 3 pezzi.

PROJECT DESCRIPTION

Fire Fighting Unit IDROFOGLIA with normalized base-coupling pump as EN733 (DIN24255) coupled to the engine by elastic joint with spacer, composed by:

Jockey Pump Section

Nr. 1 Jockey electric pump, self-priming mono-block for the maintenance of the proper water pressure into the firewater ring main, with axial suction part and radial discharge nozzle, both threaded ISO 228/1, cast iron pump, techno polymer ejector, stainless steel shaft, brass impeller, seal ceramic-graphite-NBR coupled with close electric engine supplied with externally ventilated three-phase insulation class F and IP44 protection.

The jockey pump is equipped on delivery with one check valve, one ball valve, a 20 liters expansion tank PN16, and fittings for control panel connection. The pump is automatically controlled by a galvanized control panel with an adjustable starting pressure switch IP55 protection level, gauge and pressure switch testing circuit.

The jockey electric pump is controlled by an independently control panel manufactured according to EN 12845 norm, with painted IP55 protection level sheet metal, automatic starter, composed by

- door locking switch
- contactor and overload relay
- manual selector lever 0 automatic with key
- starting signal light
- block signal light
- main present signal light
- transformer 400/24/12V for auxiliary circuits
- auxiliary circuit fuses
- terminal board and cable glands
- power input 400 (3F) 50 Hz

Main (or backup) Electric Pump Section

Nr. 1 Electric pump base-coupling type with horizontal axis, impeller with axial suction port and radial discharge nozzle both flanged UNI PN 16, cast iron pump, stainless steel shaft and mechanical seal in carbon/silicon carbide coupled by elastic joint with spacer to a three-phase asynchronous engine B3 with external ventilation, F insulation class, winding over temperature class B, protection level IP55, 2900 rpm.

The Electric pump is controlled by and independently control panel manufactured according to EN 12845 norm, with painted IP55 protection level sheet metal, automatic starter (until 9,2 kW) and star delta starting (from 11 kW) composed by:

- door lock switches
- programmable electronic management with indicator led and light
- integrated weekly test
- interlocked mono-phase 16A service power point
- manual selector level 0 automatic with key
- start and stop buttons
- phase failure and phase sequence relay
- buffer battery with charger
- transformer 400/24/12V for auxiliary circuits
- auxiliary circuit fuses
- general fuses
- nr. 3 contactors
- swap timer
- ampere meter
- voltmeter with voltmeter switch
- flashing with buzzer
- terminal board
- power input 400 (3F+N) 50 Hz

Main (or backup) Diesel Motor Pump Section

Nr. 1 Diesel Motor pump base-coupling type with horizontal axis, impeller with axial suction port and radial discharge nozzle both flanged UNI PN16, cast iron

pump, stainless steel shaft and mechanical seal in carbon/silicon carbide coupled by elastic joint with spacer to a diesel engine, air cooled up to 30 kW and liquid above the 30 kW, with multiple strap belts, complete with gravity tank to guarantee 6 h autonomy and double starter battery. The diesel motor pump set shall be complete of anti-vibration joints connected to frame and compensation joint connected on suction.

The Diesel Motor pump is controlled by an independent control panel manufactured according to EN12845 norm, with painted IP55 protection level sheet metal, composed by:

- door lock switches
- programmable electronic management with indicator led and light
- indications and alarms on display
- manual selector – automatic with key
- nr. 2 battery charges 12/24V with microprocessor control complete of nr. 2 transformers 230/16V and power supply separate circuits
- battery control on display
- auxiliary circuit fuses
- analogic tachometer
- integrated weekly test
- preheating differential magneto thermic
- terminal board
- power input 230(F+N) 50 Hz

Each pump is equipped with a vacuum gauge on suction. The discharge is equip-

ped in sequence by a flanged rubber joint, a taper pipe flanged to guarantee 6 m/s, predisposed for priming tank connection, a brass orifice plate of 3/8" air pump recycle and reject, a manometer, an inspected non return valve, a galvanized diaphragm with 1/2" output for pump started panel connection and a shut-off butterfly valve. The pumps are automatically controlled by galvanized control panel, connected to the diaphragm by RILSAN 2034 15/12.5 pa12 hose, where there are 2 adjustable starting pressure with IP55 level protection, gauge and pressure circuit test.

On the delivery manifold there is a predisposition for the "manifold test". The manifold is supported by two "legs" connected to the main frame to guarantee the service stability and continuity.

Control panels, pumps and engines are installed on a galvanized steel frame.

ACCESSORIES:

- Flow meter Kit adequately sized, composed by:
 - Postponed reading flow meter
 - Galvanized steel manifold
 - Shut off valve
 - Control panel for alarm maintaining with remote control. Control panel for A and B alarms grouping with the possibility to connect sirens and to interface it, trough clean contacts, with the eventual supervision system;
 - In case of suction lift installation, each service pump is equipped on suction by an eccentric double flanged reduction (if it is necessary), to guarantee in suction a water speed equal to 1,5 m/s, and it is maintained constantly charged by an LLDPE priming tank of 500 lt which must be connected to the service pump by a diameter 50 mm hose.
- On the connection there is applied a check valve.
- The tank is preserved fully by hydrological networks with applied a float valve. If the tank level, for any foot valve losses, falls below 2/3 there is a level switch that allow the service pump starting.
- In case of positive head installation, each service pump is equipped on suction by an eccentric double flanged reduction (if it is necessary), to guarantee in suction a water speed equal to 1,8 m/s and a shut-off valve (butterfly valve "Lug" type) and the jockey pump is equipped with a ball valve with 3 pieces joint.

PRESTAZIONI POMPE PUMPS PERFORMANCES

DATI TECNICI TECHNICAL DATA

PUMP MODEL	engine power					limit HHS HHP m³/h	limit NPSH 5m m³/h	portata l/min m³/h	hydraulic performance															
	electric		diesel		jockey				100	133	233	267	333	375	417	500	542	583	625	667	708	750	833	917
	kW	type	kW NA	type	kW				6	8	14	16	20	22,5	25	30	32,5	35	37,5	40	42,5	45	50	55
32-200-NC	4	L	4,2	or	1,1	20	20	45	44	39,8	38,2	34,4	30	27,5										
32-200-NB	5,5	L	6,2	or	1,1	22,5	25	53	52,8	51,1	50,2	47,4	45	43	35									
32-200-NA	7,5	L	7,1	or	1,1	25	25	62,8	62,6	62,2	62	59,5	59	57,5	49,7	45	38,6							
32-250-E	11	L	13,6	or	2,2	32,5	37,5		64	63,5	63,4	62,5	62	61	59,5	58,5	57,4	56	55	52,5				
32-250-225	15	L	13,6	or	1,1	30	30					69	68	67	62	59	55	49	42					
32-250-235	15	L	17,6	or	2,2	30	30					76	75	74	70	67	63	58	53	43				
32-250-245	18,5	L	17,6	or	2,2	32,5	30					83,5	82,5	81	76,5	73,5	75	66	61	54	47			
32-250-B	22	P	20,1	or	2,2	42	45	H mt	85,6	85	84	83,6	83	82,8	81	79	78,5	77	75,5	74	73	70	65,6	
32-250-255	18,5	L	17,6	or	2,2	32,5	30					89	88	87	82,5	79,5	77	73	68	62	54			
32-250-264	18,5	P	20,1	or	2,2	32,5	31					95	93,5	92,5	88	85	82	78	73	66	58			
32-250-A	22	L	24	or	2,2	45	45		94,5	94	94	92,5	92	92	90	89	88	86	85	83	81	77	71	
40-200-185	7,5	L	7,1	or	1,1	30	33					46	45,5	44	41	39	37	34	30	26	21			
40-200-195	9	L	10,4	or	1,1	32,5	35					52,5	51,5	50	47	45,5	43	40,5	37	34	30			
40-200-205	11	L	10,4	or	1,1	32,5	35					58	57,5	57	54	52,5	50	47,5	44	41	37	26		
40-200-214	11	L	10,4	or	1,1	35	35					62,5	61,5	61	58,5	57	55	52,5	50	46,5	43	33		
40-200-NA	11	L	13,6	or	2,2	40	55					60	59,5	59	57	56,5	56	55	54	52	50	47	41,5	

PUMP MODEL	engine power					limit HHS HHP m³/h	limit NPSH 5m m³/h	portata l/min m³/h	hydraulic performance															
	electric		diesel		jockey				333	417	500	583	667	750	833	917	1000	1083	1167	1250	1333	1417	1500	1667
	kW	type	kW NA	type	kW				20	25	30	35	40	45	50	55	60	65	70	75	80	85	90	100
40-250-225	15	L	17,6	or	1,1	40	52		63	62	60	57	53	48	41	34								
40-250-235	18,5	L	17,6	or	2,2	45	52		70,5	69	68	66	62	57	51	44	30							
40-250-245	22	P	20,1	or	2,2	45	52		78	77	76	74	70	66	61	54	52							
40-250-255	22	P	20,1	or	2,2	50	52		86	85	82	81	78	74	69	62,5	61	34						
40-250-264	22	L	24	or	2,2	50	53		93	91	89	87	84	80	76	70	60,5	46						
40-250-264	22	P	26,8	or	2,2	50	53		93	91	89	87	84	80	76	70	60,5	46						
40-315-RB300	45	V	48	vt	1,5	50	55		112	111,5	111	110,5	110	109	107,5	105,5	103,5	100	98					
40-315-RAB308	45	V	48	vt	1,5	50	50		122	121	120,5	120	119,5	118	117	115	113	110	107,5					
40-315-RAB315	55	V	48	vt	2,2	50	55		131,5	131	130,5	130	129	128	127	124,5	122,5	120	117					
50-160-174	15	L	13,6	or	1,1	80	66					42	41,5	41	40	39	38	37,5	36	35	33,5	32	30	26,5
50-200-185	11	L	10,4	or	1,1	50	55					44	43	41,5	39	37	33,5	30	27	22	16			
50-200-195	15	L	13,6	or	1,1	55	55					49,5	48,5	47,5	45,5	43	41	37	34	28	24	18		
50-200-C	11	L	10,4	or	1,1	50	65		52	51	49,6	47,8	45,9	43,4	41	38	35	32	28					
50-200-B	11	L	13,6	or	1,1	50	65		57	56	54	52	50	47	44	41	37	33						
50-200-205	15	L	17,6	or	1,1	60	55					54,5	53,5	52,5	50,5	48,5	46	43	40	36	32	27	21	
50-200-A	15	L	13,6	or	2,2	50	65		60	59	58	56,5	55	53	50,5	48	43	41	30					
50-200-214	18,5	L	17,6	or	1,1	65	55	H mt				58,5	57,5	56	53,5	51	48,5	45,5	41,5	38	33	28		
50-200-NB	18,5	P	20,1	or	1,1	75	75							57	55	53	51,5	50	48	47	45	42	37	
50-200-NA	22	L	24	or	2,2	82,5	95							67	66	65	64	62	60	58	55	52,5	45,5	
50-200-NA	22	P	26,8	or	2,2	82,5	95							67	66	65	64	62	60	58	55	52,5	45,5	
50-250-225	18,5	P	20,1	or	2,2	50	65					65	63,5	61	58	54	50	44	36	24				
50-250-235	22	L	24	or	2,2	50	65					74	72,5	71,5	68,5	65	61,5	56,5	50	40	26			
50-250-235	22	P	26,8	or	2,2	50	65					74	72,5	71,5	68,5	65	61,5	56,5	50	40	26			
50-250-245	30	L	24	or	2,2	55	65					84	82,5	81	78	75	71,5	67,5	62	55,5	46	30		
50-250-245	30	P	26,8	or	2,2	55	65					84	82,5	81	78	75	71,5	67,5	62	55,5	46	30		
50-250-255	30	V	33	or	2,2	60	65					92	91	90	88	86	83	79	75	69,5	62	52	38	
50-250-264	30	V	33	or	2,2	65	65					101	100	98	96	93,5	91	88	84	79,5	73,5	65,5	56	
50-250-264	30	P	37,5	or	2,2	65	65					101	100	98	96	93,5	91	88	84	79,5	73,5	65,5	56	
50-250-NA	37	V	33	or	2,2	70	100		100	99,5	99	98	97	94,5	93	90,5	87,5	84	80	76,5	70	66	55	
50-250-NA	37	P	37,5	or	2,2	70	100		100	99,5	99	98	97	94,5	93	90,5	87,5	84	80	76,5	70	66	55	
50-315-274	45	V	48	vt	1,5	60	80					100	98	96	94	91	89	86	81	74	66	60		
50-315-291	55	V	48	vt	1,5	70	85					115	114	112	110	108	106	102	99	94	90	82	74	
50-315-308	75	V	65	vt	1,5	70	90					130	128	127	125	123	122	119	117	114	110	106	100	

PRESTAZIONI POMPE
PUMPS PERFORMANCES

DATI TECNICI TECHNICAL DATA

PUMP MODEL	engine power					limit HHS HHP mc/h	limit NPSH 5m mc/h	portata l/min mc/h	hydraulic performance															
	electric		diesel		jockey				667	833	1000	1167	1333	1500	1667	1833	2000	2167	2333	2500	2667	2833	3000	3167
	kW	type	kW NA	type	kW				40	50	60	70	80	90	100	110	120	130	140	150	160	170	180	190
65-200-185	22	P	20,1	or	1,1	110	120				45	44	42,5	40,5	38	36,5	34	32	28	25	20	15		
65-200-NA	30	V	33	or	2,2	120	130	66,5	66	65	64,7	63,7	62	60	58	55,6	53	50	47	43	38	34		
65-200-195	30	L	24	or	1,1	120	120			51,5	50,5	48,5	47	45	43	41	38,5	36,5	34	30	26	21		
65-200-195	30	P	26,8	or	1,1	120	120			51,5	50,5	48,5	47	45	43	41	38,5	36,5	34	30	26	21		
65-200-205	30	P	26,8	or	1,1	130	120			57	56	55	53	52	49,5	47,5	46	43,5	41,5	38,5	35	31	25	
65-200-214	37	V	33	or	2,2	140	120			61,5	60,5	60	58	57	55	53,5	52	50	47	45,5	43	39,5	35,5	
65-200-214	37	P	37,5	or	2,2	140	120			61,5	60,5	60	58	57	55	53,5	52	50	47	45,5	43	39,5	35,5	
65-250-225	37	V	33	or	2,2	120	126			66	65	64	63	61	58	56	53	48	45	40	36	26,5		
65-250-225	37	P	37,5	or	2,2	120	126			66	65	64	63	61	58	56	53	48	45	40	36	26,5		
65-250-NB	37	V	33	or	2,2	110	110	H mt	75	74,4	73,5	72,5	72	69	67	63,5	62,5	60	57,5					
65-250-NB	37	P	37,5	or	2,2	110	110		75	74,4	73,5	72,5	72	69	67	63,5	62,5	60	57,5					
65-250-235	37	V	48	or	2,2	120	126			74	73	72	71	68	67,5	65	61	58	55	48	44	37,5		
65-250-235	37	P	37,5	or	2,2	120	126			74	73	72	71	68	67,5	65	61	58	55	48	44	37,5		
65-250-245	45	V	48	or	2,2	130	126			80	79	78	77,5	76	74	72,5	70	67,5	64	58	54	42,5	34	
65-250-255	55	V	48	or	2,2	140	126			88	87,5	86	85	83	81	80	77,5	74	71	67,5	62,5	57,5	52,5	
65-250-NOA	45	V	48	or	2,2	110	110		92	91,8	91	90	89	87	84,5	82,5	78	76,5	74	71	68	65,5		
65-250-264	55	V	65	or	2,2	150	126			93	92,5	91	90	88	86	85	82,5	80	77,5	74	70	65	61	
65-250-NO	55	V	48	or	2,2	110	110		95	94,8	94	93	92	90	87,6	85	82	78,5	76					

PUMP MODEL	engine power					limit HHS HHP mc/h	limit NPSH 5m mc/h	portata l/min mc/h	hydraulic performance													
	electric		diesel		jockey				667	1000	1333	1500	1667	2000	2333	2500	2667	2833	3000			
	kW	type	kW NA	type	kW				40	60	80	90	95	100	120	130	140	150	160	170	180	
65-315-RCD273	55	V	65	vt	1,5	100	120			100	98	96,5	96	95	90	87,5	85,5	84	83	79		
65-315-RBC282	75	V	65	vt	1,5	100	120	H mt	112	111	108,5	107,5	107	106	102,5	100	98	95,5	94	90,5	88	
65-315-291	90	V	100	vt	1,5	130	165			113	111	110,5	110	106	103	100	96	92	88	82		
65-315-308	110	I	130,5	vt	1,5	140	180			126	125	124	123	120	118	115	113	109	106	100		

PUMP MODEL	engine power					limit HHS HHP mc/h	limit NPSH 5m mc/h	portata l/min mc/h	hydraulic performance															
	electric		diesel		jockey				1333	1667	2000	2167	2333	2500	2833	3000	3167	3333	3500	3667	3833	4000	4167	4333
	kW	type	kW NA	type	kW				80	100	120	130	140	150	170	180	190	200	210	220	230	240	250	260
80-200-195	30	V	33	or	1,1	190	204			49	48	47	46	44	42,5	41,5	40	39	37,5	36	34	31	28	
80-200-195	30	P	37,5	or	1,1	190	204			49	48	47	46	44	42,5	41,5	40	39	37,5	36	34	31	28	
80-200-205	37	V	48	or	1,1	200	204			56	55	54	53	51	50	49	47,5	46	45	43,5	42	40	38	
80-200-205	37	P	37,5	or	1,1	200	204			56	55	54	53	51	50	49	47,5	46	45	43,5	42	40	38	
80-200-214	45	V	48	or	2,2	220	204			65,5	62	61	60	58	57	56	54	53	52	51	49	48	46	
80-250-225	45	V	48	or	2,2	170	204	H mt					61	60	57	55	52	50	46	42	38	33	26	
80-250-235	55	V	48	or	2,2	180	200						69	68	65	64	62	59	56	54	50	46	36	
80-250-245	55	V	65	or	2,2	190	200						77	76	74	72	70	68	65	63	61	57	48	
80-250-255	75	V	65	or	2,2	200	200						84	84	81	80	78	77	75	73	70	67	60,5	
80-250-264	75	V	100	or	2,2	210	200						90	90	88,5	88	86	85	83	81	79	76	70	
80-250-A	110	V	98	or	2,2	250	250			102	102	102	101	101	99	98	98	97	96	95	95	94	92	90

PUMP MODEL	engine power					limit HHS HHP mc/h	limit NPSH 5m mc/h	portata l/min mc/h	hydraulic performance															
	electric		diesel		jockey				2833	3000	3167	3333	3667	3833	4000	4167	4333	4500	4667	5000	5333	5667	6000	
	kW	type	kW NA	type	kW				170	180	190	200	220	230	240	250	260	270	280	300	320	340	360	
100-200-195	37	V	48	or	1,1	260	276			47,5	47	46	45	43,5	42	41	39,5	38,5	37	36	33,5	32	28	24
100-200-195	37	P	37,5	or	1,1	260	276	H mt	47,5	47	46	45	43,5	42	41	39,5	38,5	37	36	33,5	32	28	24	
100-200-205	55	V	48	or	1,1	280	282			55	54,5	54	53	51	50	48,5	47,5	46,5	45	44	41,5	38,5	36	32,5
100-200-214	55	V	65	or	2,2	300	276			60,5	60	59,5	59	57,5	56,5	55,5	54	53	52	51	48	46	43	40

PRESTAZIONI POMPE PUMPS PERFORMANCES

DATI TECNICI TECHNICAL DATA

PUMP MODEL	engine power					limit HHS HHP mc/h	limit NPSH 5m mc/h	portata l/min mc/h	hydraulic performance															
	electric		diesel		jockey				2500	2917	3333	3750	4167	4583	5000	5417	5833	6250	6667	7083	7917	8333	8750	9166
	kW	type	kW NA	type	kW				150	175	200	225	250	275	300	325	350	375	400	425	475	500	525	550
100-250-225	75	V	65	or	2,2	275	300																	
100-250-235	75	V	100	or	2,2	275	300																	
100-250-245	90	V	100	or	2,2	300	300																	
100-250-255	110	V	130,5	or	2,2	325	300																	
100-250-264	132	I	130,5	or	2,2	325	300																	
100-315-291	110	I	130,5	vt	1,5	250	300																	
100-315-RBC292	132	I	130,5	vt	1,5	275	275																	
100-315-RBC296	160	I	178	vt	1,5	275	275																	
100-315-RBC308	160	I	178	vt	1,5	290	290																	
100-315-308	132	I	130,5	vt	1,5	250	300																	
125-200-205	75	V	65	or	1,1	375	350	H mt																
125-200-214	75	V	100	or	1,1	400	350																	
125-250-RC	90	V	100	or	2,2	385	375																	
125-250-RB	132	I	130,5	or	2,2	425	350																	
125-250-RAB	160	I	178	or	2,2	425	350																	
125-250-250	132	I	130,5	vt	1,1	375	420																	
125-250-264	132	I	130,5	vt	1,1	400	420																	
125-315-RBC287	160	I	178	vt	1,5	325	325																	
125-315-RCD295	160	I	178	vt	1,5	350	350																	
125-250-278	160	I	178	vt	1,5	475	420																	
125-315-RBC302	200	I	178	vt	1,5	325	325																	

PUMP MODEL	engine power					limit HHS HHP mc/h	limit NPSH 5m mc/h	portata l/min mc/h	hydraulic performance													
	electric		diesel		jockey				3333	4167	5000	5833	6667	7500	8333	9167	10000	10833	11667	12500		
	kW	type	kW NA	type	kW				200	250	300	350	400	450	500	550	600	650	700	750		
150-315-RC257	160	I	178	vt	1,1	450	575															
150-315-RC266	160	I	178	vt	1,1	525	525															
150-315-RCD280	200	I	200	vt	1,1	500	580															
150-315-RC290	250	I	227	vt	1,5	475	475															
150-315-RBC284	200	I	200	vt	1,1	500	625	H mt														
150-315-RBC290	250	I	227	vt	1,5	525	700															
150-315-RAB310	315	I	282	vt	1,5	525	525															
150-315-RAB315	315	I	282	vt	1,5	550	675															

IDROFIRE BG P1E

N.1 ELETTROPOMPA DI SERVIZIO + PILOTA
NR.1 MAIN ELECTRIC PUMP + JOCKEY PUMP

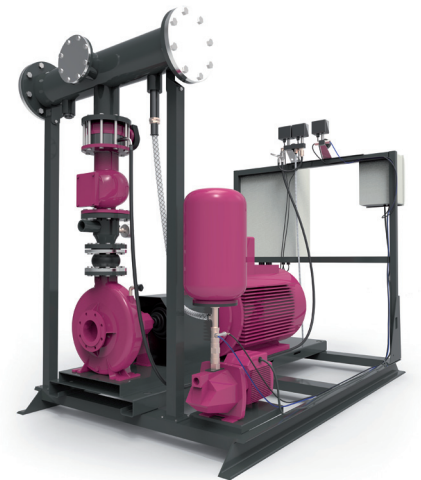

ELENCO COMPONENTI COMPONENT LIST

- | | |
|--|--|
| <ol style="list-style-type: none"> 1. Elettropompa di servizio accoppiata mediante giunto spaziatore completo di protezione coprigiunto 2. Elettropompa pilota 3. Valvola di ritegno a clapet 4. Valvola di intercettazione lucchettabile 5. Valvola di ritegno 6. Valvola di intercettazione a sfera con leva 7. Collettore di mandata reversibile completo di flangia cieca 8. Derivazione per collettore di prova di portata 9. Predisposizione per kit sprinkler 10. Kit avviamento per pompe principali composto da 2 pressostati 2-14 bar con pulsante di prova integrato, 1 manometro 0-16 bar e circuito by-pass 11. Kit avviamento per pompa pilota composto da 1 pressostato con pulsante di prova integrato, 1 manometro 12. Quadri elettrici di comando (uno per ogni pompa) 13. Mano-vuotometro con porta-manometro e rubinetto provvisto di flangia per controllo 14. Kit diaframma di ricircolo completo di indicatore visivo di flusso 15. Manometro 0-16 bar 16. Serbatoio Autoclave 24 lt PN16 17. Giunto di compensazione in gomma 18. Telaio | <ol style="list-style-type: none"> 1. Main electric pump coupled with coupling joint between motor and pump with spacing protected by carter butt strap 2. Jockey electric pump 3. Swing Check Valve ("Clapet" Valve) 4. Shut-off valve lockable 5. Check valve 6. Ball valve with level 7. Reversible delivery manifold with blind flange 8. Shunt for flow meter 9. Predisposition for sprinkler kit 10. Starting kit for main pump composed by 2 pressure switch 2-14 bar with integrated test button, 1 pressure gauge 0-16 bar and by-pass circuit 11. Starting kit for jockey electric pump composed by 1 pressure switch with integrated test button, 1 pressure gauge 12. Electrical control panels (one for each pump) 13. Vacuum gauge with gauge holder and cock fitted with flange for control 14. Kit recycling diaphragm complete with visual flow indicator 15. Pressure gauge 0-16 bar 16. Diaphragm pressure vessel 24LT PN16 17. Rubber strain neutralizer 18. Frame |
|--|--|

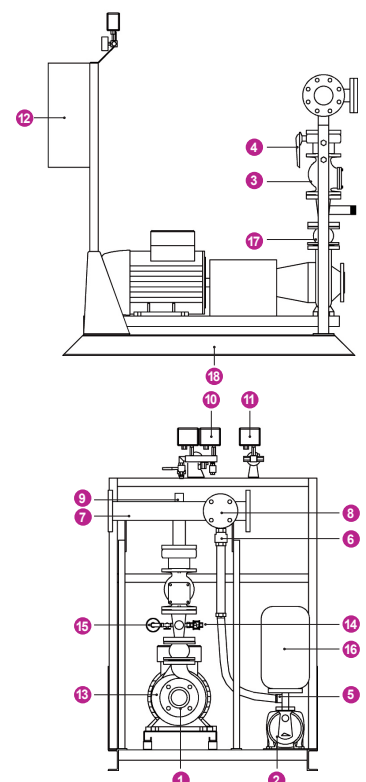

IDROFIRE BG P1E

DATI TECNICI TECHNICAL DATA

MODELLO GRUPPO	MOTORE ELETTTRICO		ELETTROPOMPA PILOTA		KIT FLUSSIMETRO	KIT ASP. SOTTOBATTENTE		KIT ASP. SOPRABATTENTE	
	ELECTRIC ENGINE		JOCKEY PUMP			pompa principale	pompa pilota		pompa principale
	MODEL GROUP		JOCKEY PUMP			FLOW METER KIT	POSITIVE HEAD KIT		SUCTION LIFT KIT
BG P1E	mod.	kW	mod.	kW	mod.	mod.	DN	mod.	
EN BG P1E 32-200-NC ES+J15	112MA	4	J15	1,1	CM50-V50	P50-S65	1"	50x80	
EN BG P1E 32-200-NB ES+J15	132SA	5,5	J15	1,1	CM50-V50	P50-S65	1"	50x80	
EN BG P1E 32-200-NA ES+J15	132SB	7,5	J15	1,1	CM50-V50	P50-S80	1"	50x80	
EN BG P1E 32-250-E ES+J3A	160MA	11	J3A	2,2	CM50-V50	P50-S80	1¼"	50x100	
EN BG P1E 32-250-E EC+J15	160MB	15	J15	1,1	CM50-V50	P50-S80	1"	50x100	
EN BG P1E 32-250-235 EC+J3A	160MB	15	J3A	2,2	CM50-V50	P50-S80	1¼"	50x100	
EN BG P1E 32-250-245 EC+J3A	160L	18,5	J3A	2,2	CM50-V50	P50-S80	1¼"	50x100	
EN BG P1E 32-250-B ES+J3A	180M	22	J3A	2,2	CM50-V50	P50-S100	1¼"	50x100	
EN BG P1E 32-250-255 EC+J3A	160L	18,5	J3A	2,2	CM50-V50	P50-S80	1¼"	50x100	
EN BG P1E 32-250-264 EC+J3A	160L	18,5	J3A	2,2	CM50-V50	P50-S80	1¼"	50x100	
EN BG P1E 32-250-A ES+J3A	180M	22	J3A	2,2	CM50-V50	P50-S100	1¼"	50x100	
EN BG P1E 40-200-185 EC+J15	132SB	7,5	J15	1,1	CM50-V50	P65-S80	1"	65x100	
EN BG P1E 40-200-195 EC+J15	132M	9	J15	1,1	CM50-V50	P65-S80	1"	65x100	
EN BG P1E 40-200-205 EC+J15	160MA	11	J15	1,1	CM50-V50	P65-S100	1"	65x100	
EN BG P1E 40-200-214 EC+J15	160MA	11	J15	1,1	CM50-V50	P65-S100	1"	65x100	
EN BG P1E 40-200-NA ES+J3A	160MA	11	J3A	2,2	CM65-V50	P65-S100	1¼"	65x100	
EN BG P1E 40-250-225 EC+J15	160MB	15	J15	1,1	CM65-V50	P65-S100	1"	65x125	
EN BG P1E 40-250-235 EC+J3A	160L	18,5	J3A	2,2	CM65-V50	P65-S100	1¼"	65x125	
EN BG P1E 40-250-245 EC+J3A	180M	22	J3A	2,2	CM65-V50	P65-S100	1¼"	65x125	
EN BG P1E 40-250-255 EC+J3A	180M	22	J3A	2,2	CM65-V50	P65-S100	1¼"	65x125	
EN BG P1E 40-250-264 EC+J3A	180M	22	J3A	2,2	CM65-V50	P65-S100	1¼"	65x125	
EN BG P1E 40-315-RB300 ES+V18	225M	45	V18	2,2	CM65 - V50	P65-S100	1½"	65x125	
EN BG P1E 40-315-RAB308 ES+V18	225M	45	V18	2,2	CM65 - V50	P65-S100	1½"	65x125	
EN BG P1E 40-315-RAB315 ES+V18	250M	55	V18	2,2	CM65 - V50	P65-S100	1½"	65x125	
EN BG P1E 50-160-174 EC+J15	160MB	15	J15	1,1	CM65 - V50	P65-S150	1"	65x150	
EN BG P1E 50-200-185 EC+J15	160MA	11	J15	1,1	CM65-V50	P65-S125	1"	65x125	
EN BG P1E 50-200-195 EC+J15	160MB	15	J15	1,1	CM65-V50	P65-S125	1"	65x125	
EN BG P1E 50-200-C ES+J15	160MA	11	J15	1,1	CM65 - V50	P65-S125	1"	65x125	
EN BG P1E 50-200-B ES+J15	160MA	11	J15	1,1	CM65 - V50	P65-S100	1"	65x125	
EN BG P1E 50-200-205 EC+J15	160MB	15	J15	1,1	CM65-V50	P65-S125	1"	65x125	
EN BG P1E 50-200-A ES+J3A	160MB	15	J3A	2,2	CM65-V50	P65-S125	1¼"	65x125	
EN BG P1E 50-200-214 EC+J15	160L	18,5	J15	1,1	CM65 - V50	P65-S125	1"	65x125	
EN BG P1E 50-200-NB ES+J15	160L	18,5	J15	1,1	CM65 - V50	P65-S125	1"	65x150	
EN BG P1E 50-200-NA ES+J3A	180M	22	J3A	2,2	CM65 - V50	P65-S150	1¼"	65x150	
EN BG P1E 50-250-225 EC+J3A	160L	18,5	J3A	2,2	CM65-V50	P65-S125	1¼"	65x125	
EN BG P1E 50-250-235 EC+J3A	180M	22	J3A	2,2	CM65-V50	P65-S125	1¼"	65x125	
EN BG P1E 50-250-245 EC+J3A	200LA	30	J3A	2,2	CM65 - V50	P65-S125	1¼"	65x125	
EN BG P1E 50-250-255 EC+J3A	200LA	30	J3A	2,2	CM65 - V50	P65-S125	1¼"	65x125	
EN BG P1E 50-250-264 EC+J3A	200LA	30	J3A	2,2	CM65 - V50	P65-S125	1¼"	65x125	
EN BG P1E 50-250-NA ES+J3A	200LB	37	J3A	2,2	CM65 - V50	P65-S150	1¼"	65x150	
EN BG P1E 50-315-274 EC+V12	225M	45	V12	1,5	CM65-V50	P80-S125	1½"	80x125	
EN BG P1E 50-315-291 EC+V18	250M	55	V18	2,2	CM65-V50	P80-S125	1½"	80x125	
EN BG P1E 50-315-308 EC+V18	280S	75	V18	2,2	CM65-V50	P80-S125	1½"	80x125	
EN BG P1E 65-200-185 EC+J15	180M	22	J15	1,1	CM100-V80	P80-S200	1"	80x200	
EN BG P1E 65-200-NA ES+J3A	200LA	30	J3A	2,2	CM100-V80	P80-S200	1¼"	80x200	
EN BG P1E 65-200-195 EC+J15	200LA	30	J15	1,1	CM100-V80	P80-S200	1"	80x200	
EN BG P1E 65-200-205 EC+J15	200LA	30	J15	1,1	CM100-V80	P80-S200	1"	80x200	
EN BG P1E 65-200-214 EC+J3A	200LB	37	J3A	2,2	CM100-V100	P80-S200	1¼"	80x200	
EN BG P1E 65-250-225 EC+J3A	200LB	37	J3A	2,2	CM100-V80	P80-S200	1¼"	80x200	
EN BG P1E 65-250-NB ES+J3A	200LB	37	J3A	2,2	CM80-V80	P80-S150	1¼"	80x150	
EN BG P1E 65-250-235 EC+J3A	200LB	37	J3A	2,2	CM100-V80	P80-S200	1¼"	80x200	

IDROFIRE BG P1E

DATI TECNICI TECHNICAL DATA

MODELLO GRUPPO	MOTORE ELETTRICO		ELETTROPOMPA PILOTA		KIT FLUSSIMETRO	KIT ASP. SOTTOBATTENTE		KIT ASP. SOPRABATTENTE	
	ELECTRIC ENGINE		JOCKEY PUMP			pompa principale	pompa pilota		pompa principale
	MODEL GROUP					FLOW METER KIT	POSITIVE HEAD KIT		SUCTION LIFT KIT
BG P1E	mod.	kW	mod.	kW	mod.	mod.	DN	mod.	
EN BG P1E 65-250-245 EC+J3A	225M	45	J3A	2,2	CM100-V80	P80-S200	1¼"	80x200	
EN BG P1E 65-250-255 EC+J3A	250M	55	J3A	2,2	CM100-V80	P80-S200	1¼"	80x200	
EN BG P1E 65-250-NOA ES+J3A	225M	45	J3A	2,2	CM100-V80	P80-S200	1¼"	80x200	
EN BG P1E 65-250-264 EC+J3A	250M	55	J3A	2,2	CM100-V80	P80-S200	1¼"	80x200	
EN BG P1E 65-250-NO ES+J3A	250M	55	J3A	2,2	CM100-V80	P80-S150	1¼"	80x200	
EN BG P1E 65-315-RCD273 ES+V12	250M	55	V12	1,5	CM100-V80	P80-S200	1½"	80x200	
EN BG P1E 65-315-RBC282 ES+V18	280S	75	V18	2,2	CM100-V80	P80-S200	1½"	80x200	
EN BG P1E 65-315-291 EC+V18	280M	90	V18	2,2	CM100-V80	P80-S200	1½"	80x200	
EN BG P1E 65-315-308 EC+V18	315S	110	V18	2,2	CM100-V80	P80-S200	1½"	80x200	
EN BG P1E 80-200-195 EC+J15	200LA	30	J15	1,1	CM125-V100	P100-S250	1"	100x250	
EN BG P1E 80-200-205 EC+J15	200LB	37	J15	1,1	CM125-V100	P100-S250	1"	100x250	
EN BG P1E 80-200-214 EC+J3A	225M	45	J3A	2,2	CM125-V125	P100-S250	1¼"	100x250	
EN BG P1E 80-250-225 EC+J3A	225M	45	J3A	2,2	CM100-V100	P100-S200	1¼"	100x250	
EN BG P1E 80-250-235 EC+J3A	250M	55	J3A	2,2	CM125-V100	P100-S200	1¼"	100x250	
EN BG P1E 80-250-245 EC+J3A	250M	55	J3A	2,2	CM125-V100	P100-S250	1¼"	100x250	
EN BG P1E 80-250-255 EC+J3A	280S	75	J3A	2,2	CM125-V100	P100-S250	1¼"	100x250	
EN BG P1E 80-250-264 EC+J3A	280S	75	J3A	2,2	CM125-V125	P100-S250	1¼"	100x250	
EN BG P1E 80-250-A ES+J3A	315S	110	J3A	2,2	CM125-V100	P100-S200	1¼"	100x250	
EN BG P1E 100-200-195 EC+J15	200LB	37	J15	1,1	CM125-V125	P125-S250	1"	125x300	
EN BG P1E 100-200-205 EC+J15	250M	55	J15	1,1	CM125-V125	P125-S250	1"	125x300	
EN BG P1E 100-200-214 EC+J3A	250M	55	J3A	2,2	CM125-V125	P125-S250	1¼"	125x300	
EN BG P1E 100-250-225 EC+J3A	280S	75	J3A	2,2	CM125-V125	P125-S300	1¼"	125x300	
EN BG P1E 100-250-235 EC+J3A	280S	75	J3A	2,2	CM125-V125	P125-S300	1¼"	125x300	
EN BG P1E 100-250-245 EC+J3A	280M	90	J3A	2,2	CM125-V125	P125-S300	1¼"	125x300	
EN BG P1E 100-250-255 EC+J3A	315S	110	J3A	2,2	CM125-V125	P125-S300	1¼"	125x350	
EN BG P1E 100-250-264 EC+J3A	315MA	132	J3A	2,2	CM125-V125	P125-S300	1¼"	125x350	
EN BG P1E 100-315-291 EC+V18	315S	110	V18	2,2	CM125-V125	P150-S250	1½"	150x250	
EN BG P1E 100-315-RBC292 ES+V18	315MA	132	V18	2,2	CM125-V125	P125-S300	1½"	125x300	
EN BG P1E 100-315-RBC296 ES+V18	315MB	160	V18	2,2	CM125-V125	P125-S300	1½"	125x300	
EN BG P1E 100-315-RBC308 ES+V18	315MB	160	V18	2,2	CM125-V125	P125-S300	1½"	125x300	
EN BG P1E 100-315-308 EC+V18	315MA	132	V18	2,2	CM125-V125	P150-S300	1½"	150x300	
EN BG P1E 125-200-205 EC+J15	280S	75	J15	1,1	CM200-V200	P150-S300	1"	150x350	
EN BG P1E 125-200-214 EC+J15	280S	75	J15	1,1	CM200-V200	P150-S350	1"	150x350	
EN BG P1E 125-250-RC ES+J3A	280M	90	J3A	2,2	CM125-V125	P125-S300	1¼"	150x350	
EN BG P1E 125-250-RB ES+J3A	315MA	132	J3A	2,2	CM150-V125	P150-S300	1¼"	150x350	
EN BG P1E 125-250-RAB ES+J3A	315MB	160	J3A	2,2	CM150-V125	P150-S350	1¼"	150x350	
EN BG P1E 125-250-250 EC+V12	315MA	132	V12	1,5	CM200-V200	P150-S300	1½"	150x350	
EN BG P1E 125-250-264 EC+V12	315MA	132	V12	1,5	CM200-V200	P150-S300	1½"	150x350	
EN BG P1E 125-315-RBC287 ES+V18	315MB	160	V12	1,5	CM125-V125	P150-S300	1½"	150x350	
EN BG P1E 125-315-RCD295 ES+V18	315MB	160	V18	2,2	CM125-V125	P150-S300	1½"	150x350	
EN BG P1E 125-250-278 EC+V18	315MB	160	V18	2,2	CM200-V200	P150-S350	1½"	150x400	
EN BG P1E 125-315-RBC302 ES+V18	315L	200	V18	2,2	CM125-V125	P150-S300	1½"	150x350	
EN BG P1E 150-315-RC257 ES+V12	315MB	160	V12	1,5	CM200-V200	P200-S400	1½"	200x400	
EN BG P1E 150-315-RC266 ES+V12	315MB	160	V12	1,5	CM200-V200	P200-S400	1½"	200x400	
EN BG P1E 150-315-RCD280 ES+V12	315L	200	V12	1,5	CM200-V200	P200-S300	1½"	200x350	
EN BG P1E 150-315-RC290 ES+V18	355MB	250	V18	2,2	CM200-V200	P200-S400	1½"	200x450	
EN BG P1E 150-315-RBC284 ES+V18	315L	200	V18	2,2	CM200-V200	P200-S400	1½"	200x450	
EN BG P1E 150-315-RBC290 ES+V18	355MB	250	V18	2,2	CM200-V200	P200-S400	1½"	200x450	
EN BG P1E 150-315-RAB310 ES+V18	355LB	315	V18	2,2	CM200-V200	P200-S400	1½"	200x450	
EN BG P1E 150-315-RAB315 ES+V18	355LB	315	V18	2,2	CM200-V200	P200-S400	1½"	200x450	

IDROFIRE BG P1E

DIMENSIONI DIMENSIONS

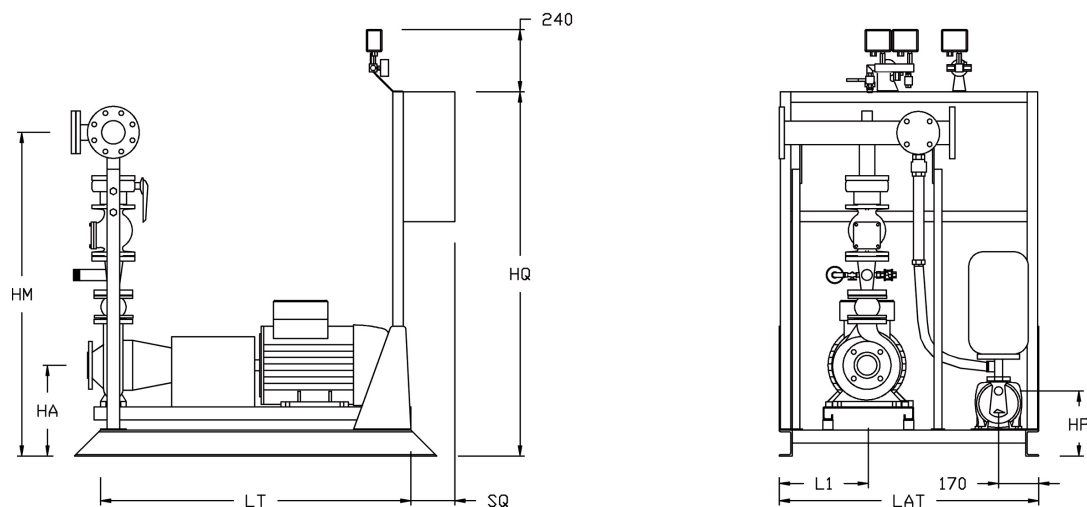

MODELLO GRUPPO	MANDATA		ASPIRAZIONE		PILOTA	HA	HM	LAT	LT	L1	HQ	SQ	HP
	kit valvole	collettore	STB	STB									
	DELIVERY valves kit	manifold	SUCTION posit. head	SUCTION posit. head									
MODEL GROUP	DN	DN	DN	DN	DN AxM	mm	mm	mm	mm	mm	mm	mm	mm
EN BG P1E 32-200-NC ES+J15	40	DN80-F50	65	80	1" x 1"	370	1243	1000	1100	350	1400	200	277
EN BG P1E 32-200-NB ES+J15	40	DN80-F50	65	80	1" x 1"	370	1243	1000	1100	350	1400	200	277
EN BG P1E 32-200-NA ES+J15	40	DN80-F50	80	80	1" x 1"	370	1243	1000	1100	350	1400	200	277
EN BG P1E 32-250-E ES+J3A	40	DN80-F50	80	100	1¼" x 1¼"	390	1308	1000	1100	350	1400	200	295
EN BG P1E 32-250-225 EC+J15	40	DN80-F50	80	100	1" x 1"	390	1308	1000	1100	350	1400	200	277
EN BG P1E 32-250-235 EC+J3A	40	DN80-F50	80	100	1¼" x 1¼"	390	1308	1000	1100	350	1400	200	295
EN BG P1E 32-250-245 EC+J3A	40	DN80-F50	80	100	1¼" x 1¼"	390	1308	1000	1100	350	1400	200	295
EN BG P1E 32-250-B ES+J3A	50	DN80-F50	100	100	1¼" x 1¼"	390	1338	1000	1300	350	1400	200	295
EN BG P1E 32-250-255 EC+J3A	40	DN80-F50	80	100	1¼" x 1¼"	390	1308	1000	1100	350	1400	200	295
EN BG P1E 32-250-264 EC+J3A	40	DN80-F50	80	100	1¼" x 1¼"	390	1308	1000	1100	350	1400	200	295
EN BG P1E 32-250-A ES+J3A	50	DN80-F50	100	100	1¼" x 1¼"	434	1382	1000	1300	350	1400	200	295
EN BG P1E 40-200-185 EC+J15	50	DN80-F50	80	100	1" x 1"	370	1273	1000	1100	350	1400	200	277
EN BG P1E 40-200-195 EC+J15	50	DN80-F50	80	100	1" x 1"	370	1273	1000	1100	350	1400	200	277
EN BG P1E 40-200-205 EC+J15	50	DN80-F50	100	100	1" x 1"	370	1273	1000	1100	350	1400	200	277
EN BG P1E 40-200-214 EC+J15	50	DN80-F50	100	100	1" x 1"	370	1273	1000	1100	350	1400	200	277
EN BG P1E 40-200-NA ES+J3A	50	DN80-F50	100	100	1¼" x 1¼"	395	1298	1000	1100	350	1400	200	295
EN BG P1E 40-250-225 EC+J15	50	DN80-F50	100	125	1" x 1"	390	1338	1000	1100	350	1400	200	277
EN BG P1E 40-250-235 EC+J3A	50	DN80-F50	100	125	1¼" x 1¼"	390	1338	1000	1100	350	1400	200	295
EN BG P1E 40-250-245 EC+J3A	50	DN80-F50	100	125	1¼" x 1¼"	390	1338	1000	1300	350	1400	200	295
EN BG P1E 40-250-255 EC+J3A	50	DN80-F50	100	125	1¼" x 1¼"	390	1338	1000	1300	350	1400	200	295
EN BG P1E 40-250-264 EC+J3A	50	DN80-F50	100	125	1¼" x 1¼"	434	1382	1000	1300	350	1400	200	295
EN BG P1E 40-315-RB300 ES+V18	65	DN80-F50	100	125	25 x 25	445	1461	1100	1600	400	1400	200	181
EN BG P1E 40-315-RAB308 ES+V18	65	DN80-F50	100	125	25 x 25	445	1461	1100	1600	400	1400	200	181
EN BG P1E 40-315-RAB315 ES+V18	65	DN80-F50	100	125	25 x 25	445	1461	1200	1800	450	1400	200	181
EN BG P1E 50-160-174 EC+J15	65	DN80-F50	150	150	1" x 1"	395	1351	1000	1100	350	1400	200	277
EN BG P1E 50-200-185 EC+J15	65	DN80-F50	125	125	1" x 1"	370	1346	1000	1100	350	1400	200	277
EN BG P1E 50-200-195 EC+J15	65	DN80-F50	125	125	1" x 1"	395	1371	1000	1100	350	1400	200	277
EN BG P1E 50-200-C ES+J15	65	DN80-F50	125	125	1" x 1"	370	1346	1000	1100	350	1400	200	277
EN BG P1E 50-200-B ES+J15	65	DN80-F50	100	125	1" x 1"	395	1371	1000	1100	350	1400	200	277
EN BG P1E 50-200-205 EC+J15	65	DN80-F50	125	125	1" x 1"	388	1364	1000	1100	350	1400	200	277
EN BG P1E 50-200-A ES+J3A	65	DN80-F50	125	125	1¼" x 1¼"	395	1371	1000	1100	350	1400	200	295
EN BG P1E 50-200-214 EC+J15	65	DN80-F50	125	125	1" x 1"	388	1364	1000	1100	350	1400	200	277
EN BG P1E 50-200-NB ES+J15	65	DN80-F50	125	150	1" x 1"	380	1356	1000	1100	350	1400	200	277
EN BG P1E 50-200-NA ES+J3A	65	DN80-F50	150	150	1¼" x 1¼"	434	1410	1000	1300	350	1400	200	295
EN BG P1E 50-250-225 EC+J3A	65	DN80-F50	125	125	1¼" x 1¼"	390	1391	1000	1100	350	1400	200	295
EN BG P1E 50-250-235 EC+J3A	65	DN80-F50	125	125	1¼" x 1¼"	434	1435	1000	1300	350	1400	200	295

IDROFIRE BG P1E

DIMENSIONI DIMENSIONS

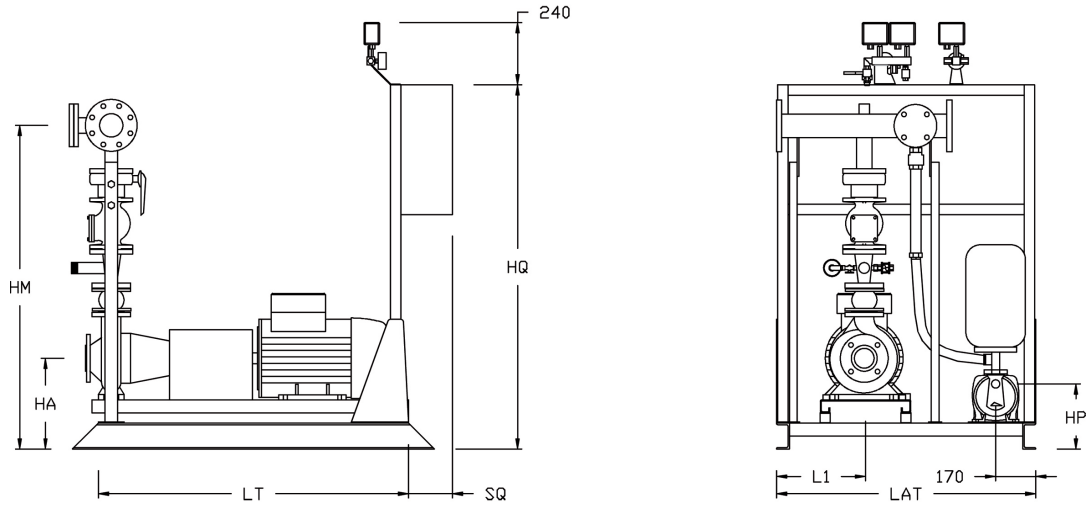

MODELLO GRUPPO	MANDATA		ASPIRAZIONE		PILOTA	HA	HM	LAT	LT	L1	HQ	SQ	HP
	kit valvole	collettore	STB	STB									
	DELIVERY valves kit	manifold	SUCTION posit. head	SUCTION posit. head									
BG P1E	DN	DN	DN	DN	DN AxM	mm	mm	mm	mm	mm	mm	mm	mm
EN BG P1E 50-250-245 EC+J3A	65	DN80-F50	125	125	1 1/4" x 1 1/4"	434	1435	1000	1300	350	1400	200	295
EN BG P1E 50-250-255 EC+J3A	65	DN80-F50	125	125	1 1/4" x 1 1/4"	400	1401	1000	1300	350	1400	200	295
EN BG P1E 50-250-264 EC+J3A	65	DN80-F50	125	125	1 1/4" x 1 1/4"	400	1401	1000	1300	350	1400	200	295
EN BG P1E 50-250-NA ES+J3A	65	DN80-F50	150	150	1 1/4" x 1 1/4"	400	1401	1000	1300	350	1400	200	295
EN BG P1E 50-315-274 EC+V12	65	DN80-F50	125	125	25 x 25	445	1501	1100	1600	400	1400	200	181
EN BG P1E 50-315-291 EC+V18	65	DN80-F50	125	125	25 x 25	445	1501	1200	1800	450	1400	200	181
EN BG P1E 50-315-308 EC+V18	65	DN80-F50	125	125	25 x 25	450	1506	1200	1800	450	1400	300	181
EN BG P1E 65-200-185 EC+J15	100	DN125-F80	200	200	1" x 1"	390	1512	1000	1300	350	1400	200	277
EN BG P1E 65-200-NA ES+J3A	100	DN125-F80	200	200	1 1/4" x 1 1/4"	400	1522	1000	1300	350	1400	200	295
EN BG P1E 65-200-195 EC+J15	100	DN125-F80	200	200	1" x 1"	434	1556	1000	1300	350	1400	200	277
EN BG P1E 65-200-205 EC+J15	100	DN125-F80	200	200	1" x 1"	400	1522	1000	1300	350	1400	200	277
EN BG P1E 65-200-214 EC+J3A	100	DN125-F80	200	200	1 1/4" x 1 1/4"	400	1522	1000	1300	350	1400	200	295
EN BG P1E 65-250-225 EC+J3A	100	DN125-F80	200	200	1 1/4" x 1 1/4"	420	1567	1000	1300	350	1400	200	295
EN BG P1E 65-250-NB ES+J3A	80	DN100-F80	150	150	1 1/4" x 1 1/4"	420	1488	1000	1300	350	1400	200	295
EN BG P1E 65-250-235 EC+J3A	100	DN125-F80	200	200	1 1/4" x 1 1/4"	420	1567	1000	1300	350	1400	200	295
EN BG P1E 65-250-245 EC+J3A	100	DN125-F80	200	200	1 1/4" x 1 1/4"	420	1567	1100	1600	400	1400	200	295
EN BG P1E 65-250-255 EC+J3A	100	DN125-F80	200	200	1 1/4" x 1 1/4"	420	1567	1200	1800	450	1400	200	295
EN BG P1E 65-250-NOA ES+J3A	100	DN125-F80	200	200	1 1/4" x 1 1/4"	420	1567	1100	1600	400	1400	200	295
EN BG P1E 65-250-264 EC+J3A	100	DN125-F80	200	200	1 1/4" x 1 1/4"	420	1567	1200	1800	450	1400	200	295
EN BG P1E 65-250-NO ES+J3A	100	DN125-F80	150	200	1 1/4" x 1 1/4"	420	1567	1200	1800	450	1400	200	295
EN BG P1E 65-315-RCD273 ES+V12	100	DN125-F80	200	200	25 x 25	445	1622	1200	1800	450	1400	200	181
EN BG P1E 65-315-RBC282 ES+V18	100	DN125-F80	200	200	25 x 25	450	1627	1200	1800	450	1400	300	181
EN BG P1E 65-315-291 EC+V18	100	DN125-F80	200	200	25 x 25	450	1627	1400	2000	550	1400	300	181
EN BG P1E 65-315-308 EC+V18	100	DN125-F80	200	200	25 x 25	555	1732	1400	2300	550	1400	300	181
EN BG P1E 80-200-195 EC+J15	125	DN150-F100	250	250	1" x 1"	400	1630	1000	1300	350	1400	200	277
EN BG P1E 80-200-205 EC+J15	125	DN150-F100	250	250	1" x 1"	400	1630	1000	1300	350	1400	200	277
EN BG P1E 80-200-214 EC+J3A	125	DN150-F100	250	250	1 1/4" x 1 1/4"	400	1630	1100	1600	400	1400	200	295
EN BG P1E 80-250-225 EC+J3A	125	DN150-F100	200	250	1 1/4" x 1 1/4"	420	1680	1100	1600	400	1400	200	295
EN BG P1E 80-250-235 EC+J3A	125	DN150-F100	200	250	1 1/4" x 1 1/4"	420	1680	1200	1800	450	1400	200	295
EN BG P1E 80-250-245 EC+J3A	125	DN150-F100	250	250	1 1/4" x 1 1/4"	420	1680	1200	1800	450	1400	200	295
EN BG P1E 80-250-255 EC+J3A	125	DN150-F100	250	250	1 1/4" x 1 1/4"	450	1710	1200	1800	450	1400	300	295
EN BG P1E 80-250-264 EC+J3A	125	DN150-F100	250	250	1 1/4" x 1 1/4"	450	1710	1200	1800	450	1400	300	295
EN BG P1E 80-250-A ES+J3A	125	DN150-F100	200	250	1 1/4" x 1 1/4"	555	1815	1400	2300	550	1400	300	295
EN BG P1E 100-200-195 EC+J15	150	DN200-F125	250	300	1" x 1"	420	1761	1000	1300	350	1400	200	277
EN BG P1E 100-200-205 EC+J15	150	DN200-F125	250	300	1" x 1"	420	1761	1200	1800	450	1400	200	277
EN BG P1E 100-200-214 EC+J3A	150	DN200-F125	250	300	1 1/4" x 1 1/4"	420	1761	1200	1800	450	1400	200	295

IDROFIRE BG P1E

DIMENSIONI DIMENSIONS

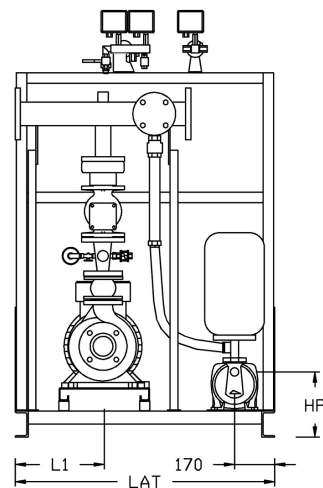
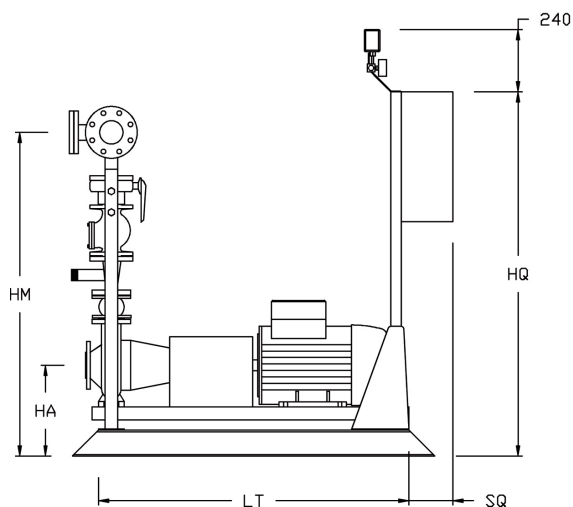

MODELLO GRUPPO	MANDATA		ASPIRAZIONE		PILOTA	HA	HM	LAT	LT	L1	HQ	SQ	HP
	kit valvole	collettore	STB	STB									
MODEL GROUP	DELIVERY		SUCTION		JOCKEY PUMP	HA	HM	LAT	LT	L1	HQ	SQ	HP
	valves kit	manifold	posit. head	posit. head		mm	mm	mm	mm	mm	mm	mm	mm
BG P1E	DN	DN	DN	DN	DN AxM	mm	mm	mm	mm	mm	mm	mm	mm
EN BG P1E 100-250-225 EC+J3A	150	DN200-F125	300	300	1 1/4" x 1 1/4"	450	1791	1200	1800	450	1400	300	295
EN BG P1E 100-250-235 EC+J3A	150	DN200-F125	300	300	1 1/4" x 1 1/4"	450	1791	1200	1800	450	1400	300	295
EN BG P1E 100-250-245 EC+J3A	150	DN200-F125	300	300	1 1/4" x 1 1/4"	450	1791	1400	2000	550	1400	300	295
EN BG P1E 100-250-255 EC+J3A	150	DN200-F125	300	350	1 1/4" x 1 1/4"	555	1896	1400	2300	550	1400	300	295
EN BG P1E 100-250-264 EC+J3A	150	DN200-F125	300	350	1 1/4" x 1 1/4"	555	1896	1400	2300	550	1400	300	295
EN BG P1E 100-315-291 EC+V18	150	DN200-F125	250	250	25 x 25	555	1931	1400	2300	550	1400	300	181
EN BG P1E 100-315-RBC292 ES+V18	150	DN200-F125	300	300	25 x 25	555	1931	1400	2300	550	1400	300	181
EN BG P1E 100-315-RBC296 ES+V18	150	DN200-F125	300	300	25 x 25	575	1951	1400	2300	550	1400	300	181
EN BG P1E 100-315-RBC308 ES+V18	150	DN200-F125	300	300	25 x 25	575	1951	1400	2300	550	1400	300	181
EN BG P1E 100-315-308 EC+V18	150	DN200-F125	300	300	25 x 25	555	1931	1400	2300	550	1400	300	181
EN BG P1E 125-200-205 EC+J15	150	DN200-F125	300	350	1" x 1"	470	1881	1200	1800	450	1400	300	277
EN BG P1E 125-200-214 EC+J15	150	DN200-F125	350	350	1" x 1"	470	1881	1200	1800	450	1400	300	277
EN BG P1E 125-250-RC ES+J3A	150	DN200-F125	300	350	1 1/4" x 1 1/4"	470	1921	1400	2000	550	1400	300	295
EN BG P1E 125-250-RB ES+J3A	150	DN200-F125	300	350	1 1/4" x 1 1/4"	555	2006	1400	2300	550	1400	300	295
EN BG P1E 125-250-RAB ES+J3A	150	DN200-F125	350	350	1 1/4" x 1 1/4"	575	2026	1400	2300	550	1400	300	295
EN BG P1E 125-250-250 EC+V12	150	DN200-F125	300	350	25 x 25	555	2006	1400	2300	550	1400	300	181
EN BG P1E 125-250-264 EC+V12	150	DN200-F125	300	350	25 x 25	555	2006	1400	2300	550	1400	300	181
EN BG P1E 125-315-RBC287 ES+V12	150	DN200-F125	250	350	25 x 25	585	2036	1400	2300	550	1400	300	181
EN BG P1E 125-315-RCD295 ES+V18	150	DN200-F125	250	350	25 x 25	595	2046	1400	2300	550	1400	300	181
EN BG P1E 125-250-278 EC+V18	150	DN200-F125	350	400	25 x 25	575	2026	1400	2300	550	1400	300	181
EN BG P1E 125-315-RBC302 ES+V18	150	DN200-F125	300	350	25 x 25	595	2046	1400	2300	550	1400	370	181
EN BG P1E 150-315-RC257 ES+V12	200	DN250-F200	400	400	25 x 25	595	2252	1400	2300	550	1400	300	181
EN BG P1E 150-315-RC266 ES+V12	200	DN250-F200	400	400	25 x 25	595	2252	1400	2300	550	1400	300	181
EN BG P1E 150-315-RCD280 ES+V12	200	DN250-F200	300	350	25 x 25	595	2252	1400	2300	550	1400	370	181
EN BG P1E 150-315-RC290 ES+V18	200	DN250-F200	400	450	25 x 25	635	2292	1600	2500	650	1400	370	181
EN BG P1E 150-315-RBC284 ES+V18	200	DN250-F200	400	450	25 x 25	595	2252	1400	2300	550	1400	370	181
EN BG P1E 150-315-RBC290 ES+V18	200	DN250-F200	400	450	25 x 25	635	2292	1600	2500	650	1400	370	181
EN BG P1E 150-315-RAB310 ES+V18	200	DN250-F200	400	450	25 x 25	635	2292	1600	2500	650	1400	370	181
EN BG P1E 150-315-RAB315 ES+V18	200	DN250-F200	400	450	25 x 25	635	2292	1600	2500	650	1400	370	181

IDROFIRE BG P2E

N.1 ELETTROPOMPA DI SERVIZIO + N.1 ELETTROPOMPA DI RISERVA + PILOTA
 NR.1 MAIN ELECTRIC PUMP + NR.1 BACKUP ELECTRIC PUMP + JOCKEY PUMP



ELENCO COMPONENTI COMPONENT LIST

- | | |
|---|---|
| <ol style="list-style-type: none"> 1. Elettropompa di servizio accoppiata mediante giunto spaziatore completo di protezione coprigiunto 2. Elettropompa di riserva accoppiata mediante giunto spaziatore completo di protezione coprigiunto 3. Elettropompa pilota 4. Valvola di ritegno a clapet 5. Valvola di intercettazione lucchettabile 6. Valvola di ritegno 7. Valvola di intercettazione a sfera con leva 8. Collettore di mandata reversibile completo di flangia cieca 9. Derivazione per collettore di prova di portata 10. Predisposizione per kit sprinkler 11. Kit avviamento per pompe principali composto da 2 pressostati 2-14 bar con pulsante di prova integrato, 1 manometro 0-16 bar e circuito by-pass 12. Kit avviamento per pompa pilota composto da 1 pressostato con pulsante di prova integrato, 1 manometro; 13. Quadri elettrici di comando (uno per ogni pompa) 14. Mano-vuotometro con porta-manometro e rubinetto provvisto di flangia per controllo 15. Kit diaframma di ricircolo completo di indicatore visivo di flusso 16. Manometro 0-16 bar 17. Serbatoio Autoclave 24 lt PN16 18. Giunto di compensazione in gomma 19. Telaio | <ol style="list-style-type: none"> 1. Main electric pump coupled with coupling joint between motor and pump with spacing protected by carter butt strap 2. Backup electric pump coupled with coupling joint between motor and pump with spacing protected by carter butt strap 3. Jockey electric pump 4. Swing Check Valve ("Clapet" Valve) 5. Shut-off valve lockable 6. Check valve 7. Ball valve with level 8. Reversible delivery manifold with blind flange 9. Shunt for flow meter 10. Predisposition for sprinkler kit 11. Starting kit for main pump composed by 2 pressure switch 2-14 bar with integrated test button, 1 pressure gauge 0-16 bar and by-pass circuit 12. Starting kit for jockey electric pump composed by 1 pressure switch with integrated test button, 1 pressure gauge 13. Electrical control panels (one for each pump) 14. Vacuum gauge with gauge holder and cock fitted with flange for control 15. Kit recycling diaphragm complete with visual flow indicator 16. Pressure gauge 0-16 bar 17. Diaphragm pressure vessel 24LT PN16 18. Rubber strain neutralizer 19. Frame |
|---|---|

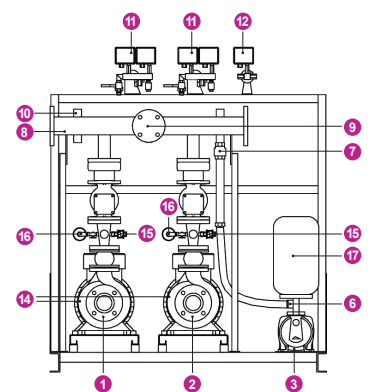
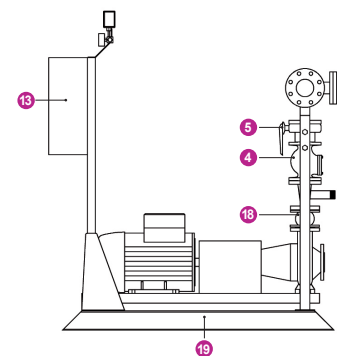

IDROFIRE BG P2E

DATI TECNICI TECHNICAL DATA

MODELLO GRUPPO	MOTORE ELETTRICO		ELETTROPOMPA PILOTA		KIT FLUSSIMETRO	KIT ASP. SOTTOBATTENTE		KIT ASP. SOPRABATTENTE	
	ELECTRIC ENGINE		JOCKEY PUMP			pompa principale	pompa pilota		pompa principale
	mod.	kW	mod.	kW		mod.	DN		mod.
EN BG P2E 32-200-NC ES+J15	112MA	4	J15	1,1	CM50-V50	P50-S65	1"	50x80	
EN BG P2E 32-200-NB ES+J15	132SA	5,5	J15	1,1	CM50-V50	P50-S65	1"	50x80	
EN BG P2E 32-200-NA ES+J15	132SB	7,5	J15	1,1	CM50-V50	P50-S80	1"	50x80	
EN BG P2E 32-250-E ES+J3A	160MA	11	J3A	2,2	CM50-V50	P50-S80	1¼"	50x100	
EN BG P2E 32-250-225 EC+J15	160MB	15	J15	1,1	CM50-V50	P50-S80	1"	50x100	
EN BG P2E 32-250-235 EC+J3A	160MB	15	J3A	2,2	CM50-V50	P50-S80	1¼"	50x100	
EN BG P2E 32-250-245 EC+J3A	160L	18,5	J3A	2,2	CM50-V50	P50-S80	1¼"	50x100	
EN BG P2E 32-250-B ES+J3A	180M	22	J3A	2,2	CM50-V50	P50-S100	1¼"	50x100	
EN BG P2E 32-250-255 EC+J3A	160L	18,5	J3A	2,2	CM50-V50	P50-S80	1¼"	50x100	
EN BG P2E 32-250-264 EC+J3A	160L	18,5	J3A	2,2	CM50-V50	P50-S80	1¼"	50x100	
EN BG P2E 32-250-A ES+J3A	180M	22	J3A	2,2	CM50-V50	P50-S100	1¼"	50x100	
EN BG P2E 40-200-185 EC+J15	132SB	7,5	J15	1,1	CM50-V50	P65-S80	1"	65x100	
EN BG P2E 40-200-195 EC+J15	132M	9	J15	1,1	CM50-V50	P65-S80	1"	65x100	
EN BG P2E 40-200-205 EC+J15	160MA	11	J15	1,1	CM50-V50	P65-S100	1"	65x100	
EN BG P2E 40-200-214 EC+J15	160MA	11	J15	1,1	CM50-V50	P65-S100	1"	65x100	
EN BG P2E 40-200-NA ES+J3A	160MA	11	J3A	2,2	CM65-V50	P65-S100	1¼"	65x100	
EN BG P2E 40-250-225 EC+J15	160MB	15	J15	1,1	CM65-V50	P65-S100	1"	65x125	
EN BG P2E 40-250-235 EC+J3A	160L	18,5	J3A	2,2	CM65-V50	P65-S100	1¼"	65x125	
EN BG P2E 40-250-245 EC+J3A	180M	22	J3A	2,2	CM65-V50	P65-S100	1¼"	65x125	
EN BG P2E 40-250-255 EC+J3A	180M	22	J3A	2,2	CM65-V50	P65-S100	1¼"	65x125	
EN BG P2E 40-250-264 EC+J3A	180M	22	J3A	2,2	CM65-V50	P65-S100	1¼"	65x125	
EN BG P2E 40-315-RB300 ES+V18	225M	45	V18	2,2	CM65 - V50	P65-S100	1½"	65x125	
EN BG P2E 40-315-RAB308 ES+V18	225M	45	V18	2,2	CM65 - V50	P65-S100	1½"	65x125	
EN BG P2E 40-315-RAB315 ES+V18	250M	55	V18	2,2	CM65 - V50	P65-S100	1½"	65x125	
EN BG P2E 50-160-174 EC+J15	160MB	15	J15	1,1	CM65 - V50	P65-S150	1"	65x150	
EN BG P2E 50-200-185 EC+J15	160MA	11	J15	1,1	CM65-V50	P65-S125	1"	65x125	
EN BG P2E 50-200-195 EC+J15	160MB	15	J15	1,1	CM65-V50	P65-S125	1"	65x125	
EN BG P2E 50-200-C ES+J15	160MA	11	J15	1,1	CM65 - V50	P65-S125	1"	65x125	
EN BG P2E 50-200-B ES+J15	160MA	11	J15	1,1	CM65 - V50	P65-S100	1"	65x125	
EN BG P2E 50-200-205 EC+J15	160MB	15	J15	1,1	CM65-V50	P65-S125	1"	65x125	
EN BG P2E 50-200-A ES+J3A	160MB	15	J3A	2,2	CM65-V50	P65-S125	1¼"	65x125	
EN BG P2E 50-200-214 EC+J15	160L	18,5	J15	1,1	CM65 - V50	P65-S125	1"	65x125	
EN BG P2E 50-200-NB ES+J15	160L	18,5	J15	1,1	CM65 - V50	P65-S125	1"	65x150	
EN BG P2E 50-200-NA ES+J3A	180M	22	J3A	2,2	CM65 - V50	P65-S150	1¼"	65x150	
EN BG P2E 50-250-225 EC+J3A	160L	18,5	J3A	2,2	CM65-V50	P65-S125	1¼"	65x125	
EN BG P2E 50-250-235 EC+J3A	180M	22	J3A	2,2	CM65-V50	P65-S125	1¼"	65x125	
EN BG P2E 50-250-245 EC+J3A	200LA	30	J3A	2,2	CM65 - V50	P65-S125	1¼"	65x125	
EN BG P2E 50-250-255 EC+J3A	200LA	30	J3A	2,2	CM65 - V50	P65-S125	1¼"	65x125	
EN BG P2E 50-250-264 EC+J3A	200LA	30	J3A	2,2	CM65 - V50	P65-S125	1¼"	65x125	
EN BG P2E 50-250-NA ES+J3A	200LB	37	J3A	2,2	CM65 - V50	P65-S150	1¼"	65x150	
EN BG P2E 50-315-274 EC+V12	225M	45	V12	1,5	CM65-V50	P80-S125	1½"	80x125	
EN BG P2E 50-315-291 EC+V18	250M	55	V18	2,2	CM65-V50	P80-S125	1½"	80x125	
EN BG P2E 50-315-308 EC+V18	280S	75	V18	2,2	CM65-V50	P80-S125	1½"	80x125	
EN BG P2E 65-200-185 EC+J15	180M	22	J15	1,1	CM100-V80	P80-S200	1"	80x200	
EN BG P2E 65-200-NA ES+J3A	200LA	30	J3A	2,2	CM100-V80	P80-S200	1¼"	80x200	
EN BG P2E 65-200-195 EC+J15	200LA	30	J15	1,1	CM100-V80	P80-S200	1"	80x200	
EN BG P2E 65-200-205 EC+J15	200LA	30	J15	1,1	CM100-V80	P80-S200	1"	80x200	
EN BG P2E 65-200-214 EC+J3A	200LB	37	J3A	2,2	CM100-V100	P80-S200	1¼"	80x200	
EN BG P2E 65-250-225 EC+J3A	200LB	37	J3A	2,2	CM100-V80	P80-S200	1¼"	80x200	
EN BG P2E 65-250-NB ES+J3A	200LB	37	J3A	2,2	CM80-V80	P80-S150	1¼"	80x150	
EN BG P2E 65-250-235 EC+J3A	200LB	37	J3A	2,2	CM100-V80	P80-S200	1¼"	80x200	

IDROFIRE BG P2E

DATI TECNICI TECHNICAL DATA

MODELLO GRUPPO	MOTORE ELETTORICO		ELETTROPOMPA PILOTA		KIT FLUSSIMETRO	KIT ASP. SOTTOBATTENTE		KIT ASP. SOPRABATTENTE	
	ELECTRIC ENGINE		JOCKEY PUMP			pompa principale	pompa pilota		pompa principale
	MODEL GROUP		JOCKEY PUMP			FLOW METER KIT	POSITIVE HEAD KIT		SUCTION LIFT KIT
BG P2E	mod.	kW	mod.	kW	mod.	mod.	DN	mod.	
EN BG P2E 65-250-245 EC+J3A	225M	45	J3A	2,2	CM100-V80	P80-S200	1¼"	80x200	
EN BG P2E 65-250-255 EC+J3A	250M	55	J3A	2,2	CM100-V80	P80-S200	1¼"	80x200	
EN BG P2E 65-250-NOA ES+J3A	225M	45	J3A	2,2	CM100-V80	P80-S200	1¼"	80x200	
EN BG P2E 65-250-264 EC+J3A	250M	55	J3A	2,2	CM100-V80	P80-S200	1¼"	80x200	
EN BG P2E 65-250-NO ES+J3A	250M	55	J3A	2,2	CM100-V80	P80-S150	1¼"	80x200	
EN BG P2E 65-315-RCD273 ES+V12	250M	55	V12	1,5	CM100-V80	P80-S200	1½"	80x200	
EN BG P2E 65-315-RBC282 ES+V18	280S	75	V18	2,2	CM100-V80	P80-S200	1½"	80x200	
EN BG P2E 65-315-291 EC+V18	280M	90	V18	2,2	CM100-V80	P80-S200	1½"	80x200	
EN BG P2E 65-315-308 EC+V18	315S	110	V18	2,2	CM100-V80	P80-S200	1½"	80x200	
EN BG P2E 80-200-195 EC+J15	200LA	30	J15	1,1	CM125-V100	P100-S250	1"	100x250	
EN BG P2E 80-200-205 EC+J15	200LB	37	J15	1,1	CM125-V100	P100-S250	1"	100x250	
EN BG P2E 80-200-214 EC+J3A	225M	45	J3A	2,2	CM125-V125	P100-S250	1¼"	100x250	
EN BG P2E 80-250-225 EC+J3A	225M	45	J3A	2,2	CM100-V100	P100-S200	1¼"	100x250	
EN BG P2E 80-250-235 EC+J3A	250M	55	J3A	2,2	CM125-V100	P100-S200	1¼"	100x250	
EN BG P2E 80-250-245 EC+J3A	250M	55	J3A	2,2	CM125-V100	P100-S250	1¼"	100x250	
EN BG P2E 80-250-255 EC+J3A	280S	75	J3A	2,2	CM125-V100	P100-S250	1¼"	100x250	
EN BG P2E 80-250-264 EC+J3A	280S	75	J3A	2,2	CM125-V125	P100-S250	1¼"	100x250	
EN BG P2E 80-250-A ES+J3A	315S	110	J3A	2,2	CM125-V100	P100-S200	1¼"	100x250	
EN BG P2E 100-200-195 EC+J15	200LB	37	J15	1,1	CM125-V125	P125-S250	1"	125x300	
EN BG P2E 100-200-205 EC+J15	250M	55	J15	1,1	CM125-V125	P125-S250	1"	125x300	
EN BG P2E 100-200-214 EC+J3A	250M	55	J3A	2,2	CM125-V125	P125-S250	1¼"	125x300	
EN BG P2E 100-250-225 EC+J3A	280S	75	J3A	2,2	CM125-V125	P125-S300	1¼"	125x300	
EN BG P2E 100-250-235 EC+J3A	280S	75	J3A	2,2	CM125-V125	P125-S300	1¼"	125x300	
EN BG P2E 100-250-245 EC+J3A	280M	90	J3A	2,2	CM125-V125	P125-S300	1¼"	125x300	
EN BG P2E 100-250-255 EC+J3A	315S	110	J3A	2,2	CM125-V125	P125-S300	1¼"	125x350	
EN BG P2E 100-250-264 EC+J3A	315MA	132	J3A	2,2	CM125-V125	P125-S300	1¼"	125x350	
EN BG P2E 100-315-291 EC+V18	315S	110	V18	2,2	CM125-V125	P150-S250	1½"	150x250	
EN BG P2E 100-315-RBC292 ES+V18	315MA	132	V18	2,2	CM125-V125	P125-S300	1½"	125x300	
EN BG P2E 100-315-RBC296 ES+V18	315MB	160	V18	2,2	CM125-V125	P125-S300	1½"	125x300	
EN BG P2E 100-315-RBC308 ES+V18	315MB	160	V18	2,2	CM125-V125	P125-S300	1½"	125x300	
EN BG P2E 100-315-308 EC+V18	315MA	132	V18	2,2	CM125-V125	P150-S300	1½"	150x300	
EN BG P2E 125-200-205 EC+J15	280S	75	J15	1,1	CM200-V200	P150-S300	1"	150x350	
EN BG P2E 125-200-214 EC+J15	280S	75	J15	1,1	CM200-V200	P150-S350	1"	150x350	
EN BG P2E 125-250-RC ES+J3A	280M	90	J3A	2,2	CM125-V125	P125-S300	1¼"	150x350	
EN BG P2E 125-250-RB ES+J3A	315MA	132	J3A	2,2	CM150-V125	P150-S300	1¼"	150x350	
EN BG P2E 125-250-RAB ES+J3A	315MB	160	J3A	2,2	CM150-V125	P150-S350	1¼"	150x350	
EN BG P2E 125-250-250 EC+V12	315MA	132	V12	1,5	CM200-V200	P150-S300	1½"	150x350	
EN BG P2E 125-250-264 EC+V12	315MA	132	V12	1,5	CM200-V200	P150-S300	1½"	150x350	
EN BG P2E 125-315-RBC287 ES+V18	315MB	160	V12	1,5	CM125-V125	P150-S300	1½"	150x350	
EN BG P2E 125-315-RCD295 ES+V18	315MB	160	V18	2,2	CM125-V125	P150-S300	1½"	150x350	
EN BG P2E 125-250-278 EC+V18	315MB	160	V18	2,2	CM200-V200	P150-S350	1½"	150x400	
EN BG P2E 125-315-RBC302 ES+V18	315L	200	V18	2,2	CM125-V125	P150-S300	1½"	150x350	
EN BG P2E 150-315-RC257 ES+V12	315MB	160	V12	1,5	CM200-V200	P200-S400	1½"	200x400	
EN BG P2E 150-315-RC266 ES+V12	315MB	160	V12	1,5	CM200-V200	P200-S400	1½"	200x400	
EN BG P2E 150-315-RCD280 ES+V12	315L	200	V12	1,5	CM200-V200	P200-S300	1½"	200x350	
EN BG P2E 150-315-RC290 ES+V18	355MB	250	V18	2,2	CM200-V200	P200-S400	1½"	200x450	
EN BG P2E 150-315-RBC284 ES+V18	315L	200	V18	2,2	CM200-V200	P200-S400	1½"	200x450	
EN BG P2E 150-315-RBC290 ES+V18	355MB	250	V18	2,2	CM200-V200	P200-S400	1½"	200x450	
EN BG P2E 150-315-RAB310 ES+V18	355LB	315	V18	2,2	CM200-V200	P200-S400	1½"	200x450	
EN BG P2E 150-315-RAB315 ES+V18	355LB	315	V18	2,2	CM200-V200	P200-S400	1½"	200x450	

IDROFIRE BG P2E

DIMENSIONI DIMENSIONS

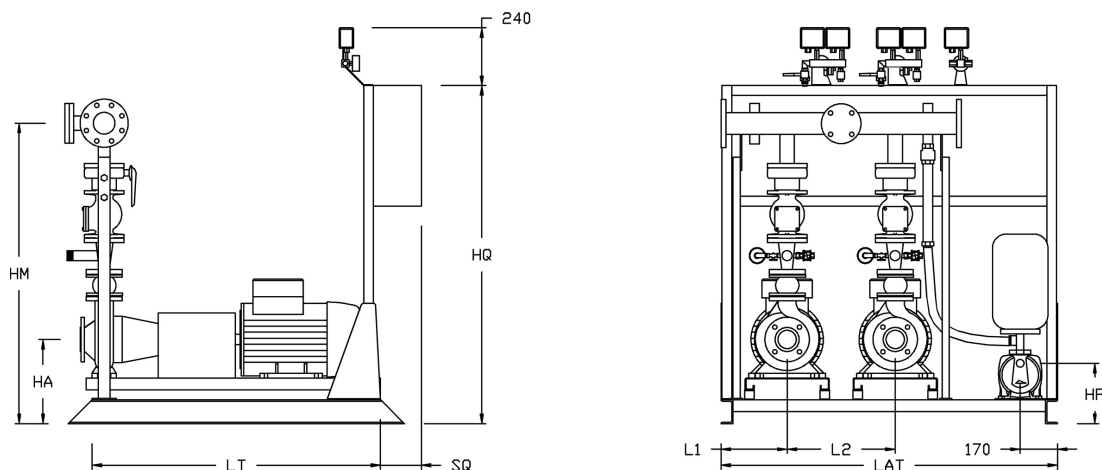

MODELLO GRUPPO	MANDATA		ASPIRAZIONE		PILOTA	HA	HM	LAT	LT	L1	L2	HQ	SQ	HP
	kit valvole	collettore	STB	STB										
	DELIVERY valves kit	manifold	SUCTION posit. head	posit. head										
BG P2E	DN	DN	DN	DN	DN AxM	mm	mm	mm	mm	mm	mm	mm	mm	mm
EN BG P2E 32-200-NC ES+J15	40	DN80-F50	65	80	1" x 1"	370	1243	1400	1100	300	500	1400	200	277
EN BG P2E 32-200-NB ES+J15	40	DN80-F50	65	80	1" x 1"	370	1243	1400	1100	300	500	1400	200	277
EN BG P2E 32-200-NA ES+J15	40	DN80-F50	80	80	1" x 1"	370	1243	1400	1100	300	500	1400	200	277
EN BG P2E 32-250-E ES+J3A	40	DN80-F50	80	100	1¼" x 1¼"	390	1308	1400	1100	300	500	1400	200	295
EN BG P2E 32-250-225 EC+J15	40	DN80-F50	80	100	1" x 1"	390	1308	1400	1100	300	500	1400	200	277
EN BG P2E 32-250-235 EC+J3A	40	DN80-F50	80	100	1¼" x 1¼"	390	1308	1400	1100	300	500	1400	200	295
EN BG P2E 32-250-245 EC+J3A	40	DN80-F50	80	100	1¼" x 1¼"	390	1308	1400	1100	300	500	1400	200	295
EN BG P2E 32-250-B ES+J3A	50	DN80-F50	100	100	1¼" x 1¼"	390	1338	1500	1300	350	500	1400	200	295
EN BG P2E 32-250-255 EC+J3A	40	DN80-F50	80	100	1¼" x 1¼"	390	1308	1400	1100	300	500	1400	200	295
EN BG P2E 32-250-264 EC+J3A	40	DN80-F50	80	100	1¼" x 1¼"	390	1308	1400	1100	300	500	1400	200	295
EN BG P2E 32-250-A ES+J3A	50	DN80-F50	100	100	1¼" x 1¼"	434	1382	1500	1300	350	500	1400	200	295
EN BG P2E 40-200-185 EC+J15	50	DN80-F50	80	100	1" x 1"	370	1273	1400	1100	300	500	1400	200	277
EN BG P2E 40-200-195 EC+J15	50	DN80-F50	80	100	1" x 1"	370	1273	1400	1100	300	500	1400	200	277
EN BG P2E 40-200-205 EC+J15	50	DN80-F50	100	100	1" x 1"	370	1273	1400	1100	300	500	1400	200	277
EN BG P2E 40-200-214 EC+J15	50	DN80-F50	100	100	1" x 1"	370	1273	1400	1100	300	500	1400	200	277
EN BG P2E 40-200-NA ES+J3A	50	DN80-F50	100	100	1¼" x 1¼"	395	1298	1400	1100	300	500	1400	200	295
EN BG P2E 40-250-225 EC+J15	50	DN80-F50	100	125	1" x 1"	390	1338	1400	1100	300	500	1400	200	277
EN BG P2E 40-250-235 EC+J3A	50	DN80-F50	100	125	1¼" x 1¼"	390	1338	1400	1100	300	500	1400	200	295
EN BG P2E 40-250-245 EC+J3A	50	DN80-F50	100	125	1¼" x 1¼"	390	1338	1500	1300	350	500	1400	200	295
EN BG P2E 40-250-255 EC+J3A	50	DN80-F50	100	125	1¼" x 1¼"	390	1338	1500	1300	350	500	1400	200	295
EN BG P2E 40-250-264 EC+J3A	50	DN80-F50	100	125	1¼" x 1¼"	434	1382	1500	1300	350	500	1400	200	295
EN BG P2E 40-315-RB300 ES+V18	65	DN80-F50	100	125	25 x 25	445	1461	1600	1600	375	550	1400	200	181
EN BG P2E 40-315-RAB308 ES+V18	65	DN80-F50	100	125	25 x 25	445	1461	1600	1600	375	550	1400	200	181
EN BG P2E 40-315-RAB315 ES+V18	65	DN80-F50	100	125	25 x 25	445	1461	1900	1800	450	700	1400	200	181
EN BG P2E 50-160-174 EC+J15	65	DN80-F50	150	150	1" x 1"	395	1351	1400	1100	300	500	1400	200	277
EN BG P2E 50-200-185 EC+J15	65	DN80-F50	125	125	1" x 1"	370	1346	1400	1100	300	500	1400	200	277
EN BG P2E 50-200-195 EC+J15	65	DN80-F50	125	125	1" x 1"	395	1371	1400	1100	300	500	1400	200	277
EN BG P2E 50-200-C ES+J15	65	DN80-F50	125	125	1" x 1"	370	1346	1400	1100	300	500	1400	200	277
EN BG P2E 50-200-B ES+J15	65	DN80-F50	100	125	1" x 1"	395	1371	1400	1100	300	500	1400	200	277
EN BG P2E 50-200-205 EC+J15	65	DN80-F50	125	125	1" x 1"	388	1364	1400	1100	300	500	1400	200	277
EN BG P2E 50-200-A ES+J3A	65	DN80-F50	125	125	1¼" x 1¼"	395	1371	1400	1100	300	500	1400	200	295
EN BG P2E 50-200-214 EC+J15	65	DN80-F50	125	125	1" x 1"	388	1364	1400	1100	300	500	1400	200	277
EN BG P2E 50-200-NB ES+J15	65	DN80-F50	125	150	1" x 1"	380	1356	1400	1100	300	500	1400	200	277
EN BG P2E 50-200-NA ES+J3A	65	DN80-F50	150	150	1¼" x 1¼"	434	1410	1500	1300	350	500	1400	200	295
EN BG P2E 50-250-225 EC+J3A	65	DN80-F50	125	125	1¼" x 1¼"	390	1391	1400	1100	300	500	1400	200	295
EN BG P2E 50-250-235 EC+J3A	65	DN80-F50	125	125	1¼" x 1¼"	434	1435	1500	1300	350	500	1400	200	295

IDROFIRE BG P2E

DIMENSIONI DIMENSIONS

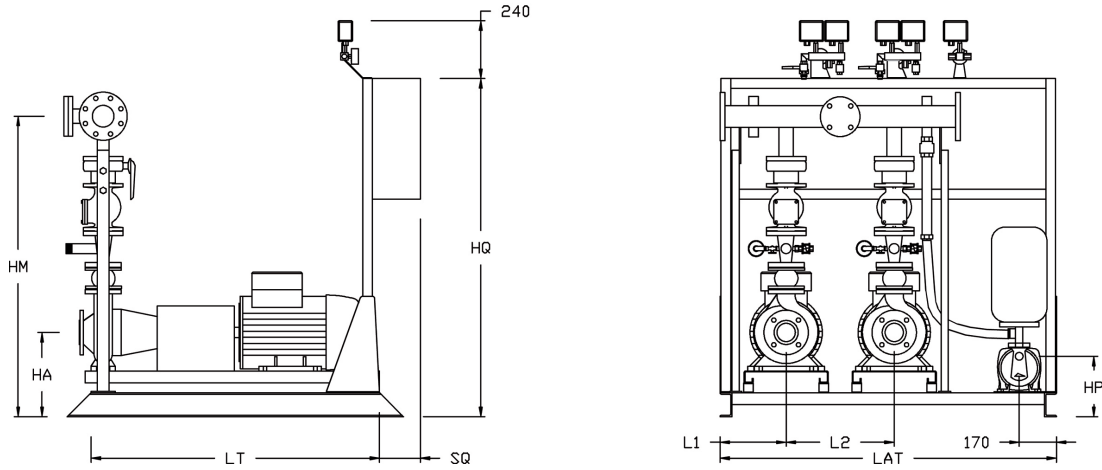

MODELLO GRUPPO	MANDATA		ASPIRAZIONE		PILOTA	HA	HM	LAT	LT	L1	L2	HQ	SQ	HP
	kit valvole	collettore	STB	STB										
	DELIVERY valves kit	manifold	SUCTION posit. head	posit. head										
DN	DN	DN	DN	DN AxM	mm	mm	mm	mm	mm	mm	mm	mm	mm	
EN BG P2E 50-250-245 EC+J3A	65	DN80-F50	125	125	1¼" x 1¼"	434	1435	1500	1300	350	500	1400	200	295
EN BG P2E 50-250-255 EC+J3A	65	DN80-F50	125	125	1¼" x 1¼"	400	1401	1500	1300	350	500	1400	200	295
EN BG P2E 50-250-264 EC+J3A	65	DN80-F50	125	125	1¼" x 1¼"	400	1401	1500	1300	350	500	1400	200	295
EN BG P2E 50-250-NA ES+J3A	65	DN80-F50	150	150	1¼" x 1¼"	400	1401	1500	1300	350	500	1400	200	295
EN BG P2E 50-315-274 EC+V12	65	DN80-F50	125	125	25 x 25	445	1501	1800	1600	375	550	1400	200	181
EN BG P2E 50-315-291 EC+V18	65	DN80-F50	125	125	25 x 25	445	1501	1900	1800	450	700	1400	200	181
EN BG P2E 50-315-308 EC+V18	65	DN80-F50	125	125	25 x 25	450	1506	1900	1800	450	700	1400	300	181
EN BG P2E 65-200-185 EC+J15	100	DN125-F80	200	200	1" x 1"	390	1512	1500	1300	350	500	1400	200	277
EN BG P2E 65-200-NA ES+J3A	100	DN125-F80	200	200	1¼" x 1¼"	400	1522	1500	1300	350	500	1400	200	295
EN BG P2E 65-200-195 EC+J15	100	DN125-F80	200	200	1" x 1"	434	1556	1500	1300	350	500	1400	200	277
EN BG P2E 65-200-205 EC+J15	100	DN125-F80	200	200	1" x 1"	400	1522	1500	1300	350	500	1400	200	277
EN BG P2E 65-200-214 EC+J3A	100	DN125-F80	200	200	1¼" x 1¼"	400	1522	1500	1300	350	500	1400	200	295
EN BG P2E 65-250-225 EC+J3A	100	DN125-F80	200	200	1¼" x 1¼"	420	1567	1500	1300	350	500	1400	200	295
EN BG P2E 65-250-NB ES+J3A	80	DN100-F80	150	150	1¼" x 1¼"	420	1488	1500	1300	350	500	1400	200	295
EN BG P2E 65-250-235 EC+J3A	100	DN125-F80	200	200	1¼" x 1¼"	420	1567	1500	1300	350	500	1400	200	295
EN BG P2E 65-250-245 EC+J3A	100	DN125-F80	200	200	1¼" x 1¼"	420	1567	1600	1600	375	550	1400	200	295
EN BG P2E 65-250-255 EC+J3A	100	DN125-F80	200	200	1¼" x 1¼"	420	1567	1900	1800	450	700	1400	200	295
EN BG P2E 65-250-NOA ES+J3A	100	DN125-F80	200	200	1¼" x 1¼"	420	1567	1600	1600	375	550	1400	200	295
EN BG P2E 65-250-264 EC+J3A	100	DN125-F80	200	200	1¼" x 1¼"	420	1567	1900	1800	450	700	1400	200	295
EN BG P2E 65-250-M0 ES+J3A	100	DN125-F80	150	200	1¼" x 1¼"	420	1567	1900	1800	450	700	1400	200	295
EN BG P2E 65-315-RCD273 ES+V12	100	DN125-F80	200	200	25 x 25	445	1622	1900	1800	450	700	1400	200	181
EN BG P2E 65-315-RBC282 ES+V18	100	DN125-F80	200	200	25 x 25	450	1627	1900	1800	450	700	1400	300	181
EN BG P2E 65-315-291 EC+V18	100	DN125-F80	200	200	25 x 25	450	1627	2000	2000	475	750	1400	300	181
EN BG P2E 65-315-308 EC+V18	100	DN125-F80	200	200	25 x 25	555	1732	2200	2300	525	850	1400	300	181
EN BG P2E 80-200-195 EC+J15	125	DN150-F100	250	250	1" x 1"	400	1630	1500	1300	350	500	1400	200	277
EN BG P2E 80-200-205 EC+J15	125	DN150-F100	250	250	1" x 1"	400	1630	1500	1300	350	500	1400	200	277
EN BG P2E 80-200-214 EC+J3A	125	DN150-F100	250	250	1¼" x 1¼"	400	1630	1600	1600	375	550	1400	200	295
EN BG P2E 80-250-225 EC+J3A	125	DN150-F100	200	250	1¼" x 1¼"	420	1680	1600	1600	375	550	1400	200	295
EN BG P2E 80-250-235 EC+J3A	125	DN150-F100	200	250	1¼" x 1¼"	420	1680	1900	1800	450	700	1400	200	295
EN BG P2E 80-250-245 EC+J3A	125	DN150-F100	250	250	1¼" x 1¼"	420	1680	1900	1800	450	700	1400	200	295
EN BG P2E 80-250-255 EC+J3A	125	DN150-F100	250	250	1¼" x 1¼"	450	1710	1900	1800	450	700	1400	300	295
EN BG P2E 80-250-264 EC+J3A	125	DN150-F100	250	250	1¼" x 1¼"	450	1710	1900	1800	450	700	1400	300	295
EN BG P2E 80-250-A ES+J3A	125	DN150-F100	200	250	1¼" x 1¼"	555	1815	2200	2300	525	850	1400	300	295
EN BG P2E 100-200-195 EC+J15	150	DN200-F125	250	300	1" x 1"	420	1761	1500	1300	350	500	1400	200	277
EN BG P2E 100-200-205 EC+J15	150	DN200-F125	250	300	1" x 1"	420	1761	1900	1800	450	700	1400	200	277
EN BG P2E 100-200-214 EC+J3A	150	DN200-F125	250	300	1¼" x 1¼"	420	1761	1900	1800	450	700	1400	200	295

IDROFIRE BG P2E

DIMENSIONI DIMENSIONS

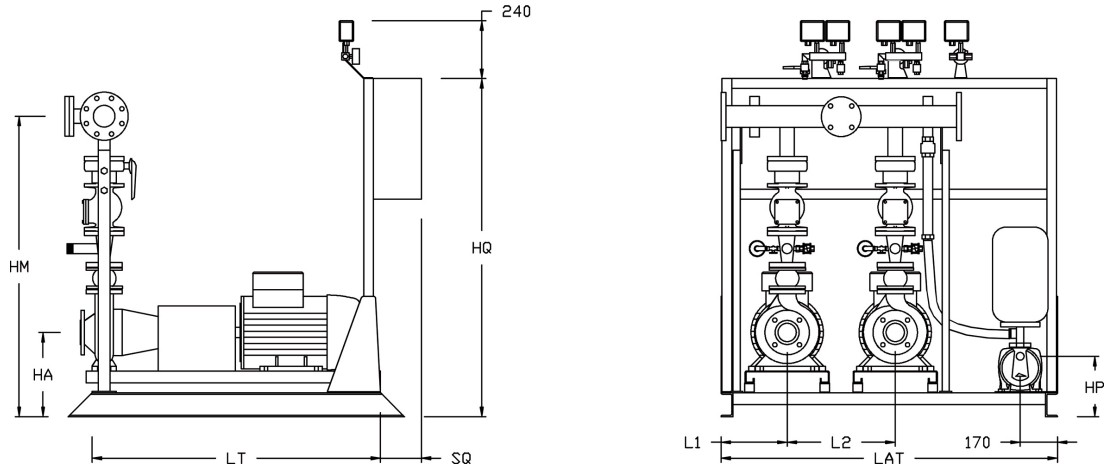

MODELLO GRUPPO	MANDATA		ASPIRAZIONE		PILOTA	HA	HM	LAT	LT	L1	L2	HQ	SQ	HP
	kit valvole	collettore	STB	STB										
	DELIVERY valves kit	manifold	SUCTION posit. head	posit. head										
DN	DN	DN	DN	DN AxM	mm	mm	mm	mm	mm	mm	mm	mm	mm	mm
EN BG P2E 100-250-225 EC+J3A	150	DN200-F125	300	300	1¼" x 1¼"	450	1791	1900	1800	450	700	1400	300	295
EN BG P2E 100-250-235 EC+J3A	150	DN200-F125	300	300	1¼" x 1¼"	450	1791	1900	1800	450	700	1400	300	295
EN BG P2E 100-250-245 EC+J3A	150	DN200-F125	300	300	1¼" x 1¼"	450	1791	2000	2000	475	750	1400	300	295
EN BG P2E 100-250-255 EC+J3A	150	DN200-F125	300	350	1¼" x 1¼"	555	1896	2200	2300	525	850	1400	300	295
EN BG P2E 100-250-264 EC+J3A	150	DN200-F125	300	350	1¼" x 1¼"	555	1896	2200	2300	525	850	1400	300	295
EN BG P2E 100-315-291 EC+V18	150	DN200-F125	250	250	25 x 25	555	1931	2200	2300	525	850	1400	300	181
EN BG P2E 100-315-RBC292 ES+V18	150	DN200-F125	300	300	25 x 25	555	1931	2200	2300	525	850	1400	300	181
EN BG P2E 100-315-RBC296 ES+V18	150	DN200-F125	300	300	25 x 25	575	1951	2200	2300	525	850	1400	300	181
EN BG P2E 100-315-RBC308 ES+V18	150	DN200-F125	300	300	25 x 25	575	1951	2200	2300	525	850	1400	300	181
EN BG P2E 100-315-308 EC+V18	150	DN200-F125	300	300	25 x 25	555	1931	2200	2300	525	850	1400	300	181
EN BG P2E 125-200-205 EC+J15	150	DN200-F125	300	350	1" x 1"	470	1881	1900	1800	450	700	1400	300	277
EN BG P2E 125-200-214 EC+J15	150	DN200-F125	350	350	1" x 1"	470	1881	1900	1800	450	700	1400	300	277
EN BG P2E 125-250-RC ES+J3A	150	DN200-F125	300	350	1¼" x 1¼"	470	1921	2000	2000	475	750	1400	300	295
EN BG P2E 125-250-RB ES+J3A	150	DN200-F125	300	350	1¼" x 1¼"	555	2006	2200	2300	525	850	1400	300	295
EN BG P2E 125-250-RAB ES+J3A	150	DN200-F125	350	350	1¼" x 1¼"	575	2026	2200	2300	525	850	1400	300	295
EN BG P2E 125-250-250 EC+V12	150	DN200-F125	300	350	25 x 25	555	2006	2200	2300	525	850	1400	300	181
EN BG P2E 125-250-264 EC+V12	150	DN200-F125	300	350	25 x 25	555	2006	2200	2300	525	850	1400	300	181
EN BG P2E 125-315-RBC287 ES+V12	150	DN200-F125	250	350	25 x 25	585	2036	2200	2300	525	850	1400	300	181
EN BG P2E 125-315-RCD295 ES+V18	150	DN200-F125	250	350	25 x 25	595	2046	2200	2300	525	850	1400	300	181
EN BG P2E 125-250-278 EC+V18	150	DN200-F125	350	400	25 x 25	575	2026	2200	2300	525	850	1400	300	181
EN BG P2E 125-315-RBC302 ES+V18	150	DN200-F125	300	350	25 x 25	595	2046	2200	2300	525	850	1400	370	181
EN BG P2E 150-315-RC257 ES+V12	200	DN250-F200	400	400	25 x 25	595	2252	2200	2300	525	850	1400	300	181
EN BG P2E 150-315-RC266 ES+V12	200	DN250-F200	400	400	25 x 25	595	2252	2200	2300	525	850	1400	300	181
EN BG P2E 150-315-RCD280 ES+V12	200	DN250-F200	300	350	25 x 25	595	2252	2200	2300	525	850	1400	370	181
EN BG P2E 150-315-RC290 ES+V18	200	DN250-F200	400	450	25 x 25	635	2292	2500	2500	575	950	1400	370	181
EN BG P2E 150-315-RBC284 ES+V18	200	DN250-F200	400	450	25 x 25	595	2252	2200	2300	525	850	1400	370	181
EN BG P2E 150-315-RBC290 ES+V18	200	DN250-F200	400	450	25 x 25	635	2292	2500	2500	575	950	1400	370	181
EN BG P2E 150-315-RAB310 ES+V18	200	DN250-F200	400	450	25 x 25	635	2292	2500	2500	575	950	1400	370	181
EN BG P2E 150-315-RAB315 ES+V18	200	DN250-F200	400	450	25 x 25	635	2292	2500	2500	575	950	1400	370	181

IDROFIRE BG ETP

N.1 ELETTROPOMPA DI SERVIZIO (O DI RISERVA)
NR.1 MAIN (OR BACKUP) ELECTRIC PUMP

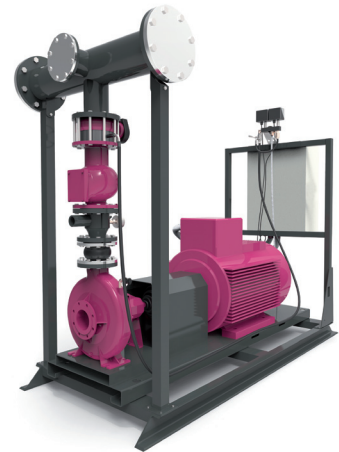

ELENCO COMPONENTI COMPONENT LIST

- | | |
|---|--|
| <ol style="list-style-type: none"> 1. Elettropompa di servizio (o di riserva) accoppiata mediante giunto spaziatore completo di protezione coprigiunto 2. Valvola di ritegno a clapet 3. Valvola di intercettazione lucchettabile 4. Collettore di mandata reversibile completo di flangia cieca 5. Derivazione per collettore di prova di portata 6. Predisposizione per kit sprinkler 7. Kit avviamento per pompe principali composto da 2 pressostati 2-14 bar con pulsante di prova integrato, 1 manometro 0-16 bar e circuito by-pass 8. Quadri elettrici di comando (uno per ogni pompa) 9. Mano-vuotometro con porta-manometro e rubinetto provvisto di flangia per controllo 10. Kit diaframma di ricircolo completo di indicatore visivo di flusso 11. Manometro 0-16 bar 12. Giunto di compensazione in gomma 13. Telaio | <ol style="list-style-type: none"> 1. Main (or backup) electric pump coupled with coupling joint between motor and pump with spacing protected by carter butt strap 2. Swing Check Valve ("Clapet" Valve) 3. Shut-off valve lockable 4. Reversible delivery manifold with blind flange 5. Shunt for flow meter 6. Predisposition for sprinkler kit 7. Starting kit for main pump composed by 2 pressure switch 2-14 bar with integrated test button, 1 pressure gauge 0-16 bar and by-pass circuit 8. Electrical control panels (one for each pump) 9. Vacuum gauge with gauge holder and cock fitted with flange for control 10. Kit recycling diaphragm complete with visual flow indicator 11. Pressure gauge 0-16 bar 12. Rubber strain neutralizer 13. Frame |
|---|--|

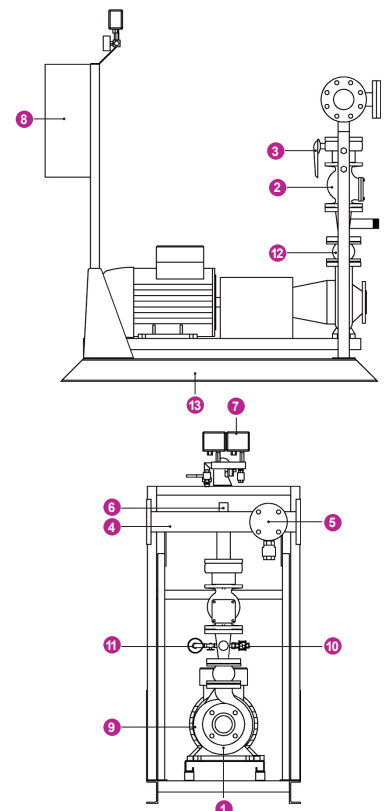

IDROFIRE BG ETP

DATI TECNICI TECHNICAL DATA

MODELLO GRUPPO	MOTORE ELETTRICO		KIT FLUSSIMETRO	KIT ASP. SOTTOBATTENTE pompa principale	KIT ASP. SOPRABATTENTE pompa principale
MODEL GROUP	ELECTRIC ENGINE		FLOW METER KIT	POSITIVE HEAD KIT main pump	SUCTION LIFT KIT main pump
BG ETP	mod.	kW	mod.	mod.	mod.
EN BG ETP 32-200-NC ES	112MA	4	CM50-V50	P50-S65	50x80
EN BG ETP 32-200-NB ES	132SA	5,5	CM50-V50	P50-S65	50x80
EN BG ETP 32-200-NA ES	132SB	7,5	CM50-V50	P50-S80	50x80
EN BG ETP 32-250-E ES	160MA	11	CM50-V50	P50-S80	50x100
EN BG ETP 32-250-225 EC	160MB	15	CM50-V50	P50-S80	50x100
EN BG ETP 32-250-235 EC	160MB	15	CM50-V50	P50-S80	50x100
EN BG ETP 32-250-245 EC	160L	18,5	CM50-V50	P50-S80	50x100
EN BG ETP 32-250-B ES	180M	22	CM50-V50	P50-S100	50x100
EN BG ETP 32-250-255 EC	160L	18,5	CM50-V50	P50-S80	50x100
EN BG ETP 32-250-264 EC	160L	18,5	CM50-V50	P50-S80	50x100
EN BG ETP 32-250-A ES	180M	22	CM50-V50	P50-S100	50x100
EN BG ETP 40-200-185 EC	132SB	7,5	CM50-V50	P65-S80	65x100
EN BG ETP 40-200-195 EC	132M	9	CM50-V50	P65-S80	65x100
EN BG ETP 40-200-205 EC	160MA	11	CM50-V50	P65-S100	65x100
EN BG ETP 40-200-214 EC	160MA	11	CM50-V50	P65-S100	65x100
EN BG ETP 40-200-NA ES	160MA	11	CM65-V50	P65-S100	65x100
EN BG ETP 40-250-225 EC	160MB	15	CM65-V50	P65-S100	65x125
EN BG ETP 40-250-235 EC	160L	18,5	CM65-V50	P65-S100	65x125
EN BG ETP 40-250-245 EC	180M	22	CM65-V50	P65-S100	65x125
EN BG ETP 40-250-255 EC	180M	22	CM65-V50	P65-S100	65x125
EN BG ETP 40-250-264 EC	180M	22	CM65-V50	P65-S100	65x125
EN BG ETP 40-315-RB300 ES	225M	45	CM65 - V50	P65-S100	65x125
EN BG ETP 40-315-RAB308 ES	225M	45	CM65 - V50	P65-S100	65x125
EN BG ETP 40-315-RAB315 ES	250M	55	CM65 - V50	P65-S100	65x125
EN BG ETP 50-160-174 EC	160MB	15	CM65 - V50	P65-S150	65x150
EN BG ETP 50-200-185 EC	160MA	11	CM65-V50	P65-S125	65x125
EN BG ETP 50-200-195 EC	160MB	15	CM65-V50	P65-S125	65x125
EN BG ETP 50-200-C ES	160MA	11	CM65 - V50	P65-S125	65x125
EN BG ETP 50-200-B ES	160MA	11	CM65 - V50	P65-S100	65x125
EN BG ETP 50-200-205 EC	160MB	15	CM65-V50	P65-S125	65x125
EN BG ETP 50-200-A ES	160MB	15	CM65-V50	P65-S125	65x125
EN BG ETP 50-200-214 EC	160L	18,5	CM65 - V50	P65-S125	65x125
EN BG ETP 50-200-NB ES	160L	18,5	CM65 - V50	P65-S125	65x150
EN BG ETP 50-200-NA ES	180M	22	CM65 - V50	P65-S150	65x150
EN BG ETP 50-250-225 EC	160L	18,5	CM65-V50	P65-S125	65x125
EN BG ETP 50-250-235 EC	180M	22	CM65-V50	P65-S125	65x125
EN BG ETP 50-250-245 EC	200LA	30	CM65 - V50	P65-S125	65x125
EN BG ETP 50-250-255 EC	200LA	30	CM65 - V50	P65-S125	65x125
EN BG ETP 50-250-264 EC	200LA	30	CM65 - V50	P65-S125	65x125
EN BG ETP 50-250-NA ES	200LB	37	CM65 - V50	P65-S150	65x150
EN BG ETP 50-315-274 EC	225M	45	CM65-V50	P80-S125	80x125
EN BG ETP 50-315-291 EC	250M	55	CM65-V50	P80-S125	80x125
EN BG ETP 50-315-308 EC	280S	75	CM65-V50	P80-S125	80x125
EN BG ETP 65-200-185 EC	180M	22	CM100-V80	P80-S200	80x200
EN BG ETP 65-200-NA ES	200LA	30	CM100-V80	P80-S200	80x200
EN BG ETP 65-200-195 EC	200LA	30	CM100-V80	P80-S200	80x200
EN BG ETP 65-200-205 EC	200LA	30	CM100-V80	P80-S200	80x200
EN BG ETP 65-200-214 EC	200LB	37	CM100-V100	P80-S200	80x200
EN BG ETP 65-250-225 EC	200LB	37	CM100-V80	P80-S200	80x200
EN BG ETP 65-250-NB ES	200LB	37	CM80-V80	P80-S150	80x150
EN BG ETP 65-250-235 EC	200LB	37	CM100-V80	P80-S200	80x200

IDROFIRE BG ETP

DATI TECNICI TECHNICAL DATA

MODELLO GRUPPO	MOTORE ELETTORICO		KIT FLUSSIMETRO	KIT ASP. SOTTOBATTENTE	KIT ASP. SOPRABATTENTE
	ELECTRIC ENGINE			pompa principale	pompa principale
MODEL GROUP			FLOW METER KIT	POSITIVE HEAD KIT	SUCTION LIFT KIT
BG ETP	mod.	kW	mod.	main pump	main pump
				mod.	mod.
EN BG ETP 65-250-245 EC	225M	45	CM100-V80	P80-S200	80x200
EN BG ETP 65-250-255 EC	250M	55	CM100-V80	P80-S200	80x200
EN BG ETP 65-250-NOA ES	225M	45	CM100-V80	P80-S200	80x200
EN BG ETP 65-250-264 EC	250M	55	CM100-V80	P80-S200	80x200
EN BG ETP 65-250-NO ES	250M	55	CM100-V80	P80-S150	80x200
EN BG ETP 65-315-RCD273 ES	250M	55	CM100-V80	P80-S200	80x200
EN BG ETP 65-315-RBC282 ES	280S	75	CM100-V80	P80-S200	80x200
EN BG ETP 65-315-291 EC	280M	90	CM100-V80	P80-S200	80x200
EN BG ETP 65-315-308 EC	315S	110	CM100-V80	P80-S200	80x200
EN BG ETP 80-200-195 EC	200LA	30	CM125-V100	P100-S250	100x250
EN BG ETP 80-200-205 EC	200LB	37	CM125-V100	P100-S250	100x250
EN BG ETP 80-200-214 EC	225M	45	CM125-V125	P100-S250	100x250
EN BG ETP 80-250-225 EC	225M	45	CM100-V100	P100-S200	100x250
EN BG ETP 80-250-235 EC	250M	55	CM125-V100	P100-S200	100x250
EN BG ETP 80-250-245 EC	250M	55	CM125-V100	P100-S250	100x250
EN BG ETP 80-250-255 EC	280S	75	CM125-V100	P100-S250	100x250
EN BG ETP 80-250-264 EC	280S	75	CM125-V125	P100-S250	100x250
EN BG ETP 80-250-A ES	315S	110	CM125-V100	P100-S200	100x250
EN BG ETP 100-200-195 EC	200LB	37	CM125-V125	P125-S250	125x300
EN BG ETP 100-200-205 EC	250M	55	CM125-V125	P125-S250	125x300
EN BG ETP 100-200-214 EC	250M	55	CM125-V125	P125-S250	125x300
EN BG ETP 100-250-225 EC	280S	75	CM125-V125	P125-S300	125x300
EN BG ETP 100-250-235 EC	280S	75	CM125-V125	P125-S300	125x300
EN BG ETP 100-250-245 EC	280M	90	CM125-V125	P125-S300	125x300
EN BG ETP 100-250-255 EC	315S	110	CM125-V125	P125-S300	125x350
EN BG ETP 100-250-264 EC	315MA	132	CM125-V125	P125-S300	125x350
EN BG ETP 100-315-291 EC	315S	110	CM125-V125	P150-S250	150x250
EN BG ETP 100-315-RBC292 ES	315MA	132	CM125-V125	P125-S300	125x300
EN BG ETP 100-315-RBC296 ES	315MB	160	CM125-V125	P125-S300	125x300
EN BG ETP 100-315-RBC308 ES	315MB	160	CM125-V125	P125-S300	125x300
EN BG ETP 100-315-308 EC	315MA	132	CM125-V125	P150-S300	150x300
EN BG ETP 125-200-205 EC	280S	75	CM200-V200	P150-S300	150x350
EN BG ETP 125-200-214 EC	280S	75	CM200-V200	P150-S350	150x350
EN BG ETP 125-250-RC ES	280M	90	CM125-V125	P125-S300	150x350
EN BG ETP 125-250-RB ES	315MA	132	CM150-V125	P150-S300	150x350
EN BG ETP 125-250-RAB ES	315MB	160	CM150-V125	P150-S350	150x350
EN BG ETP 125-250-250 EC	315MA	132	CM200-V200	P150-S300	150x350
EN BG ETP 125-250-264 EC	315MA	132	CM200-V200	P150-S300	150x350
EN BG ETP 125-315-RBC287 ES	315MB	160	CM125-V125	P150-S300	150x350
EN BG ETP 125-315-RCD295 ES	315MB	160	CM125-V125	P150-S300	150x350
EN BG ETP 125-250-278 EC	315MB	160	CM200-V200	P150-S350	150x400
EN BG ETP 125-315-RBC302 ES	315L	200	CM125-V125	P150-S300	150x350
EN BG ETP 150-315-RC257 ES	315MB	160	CM200-V200	P200-S400	200x400
EN BG ETP 150-315-RC266 ES	315MB	160	CM200-V200	P200-S400	200x400
EN BG ETP 150-315-RCD280 ES	315L	200	CM200-V200	P200-S300	200x350
EN BG ETP 150-315-RC290 ES	355MB	250	CM200-V200	P200-S400	200x450
EN BG ETP 150-315-RBC284 ES	315L	200	CM200-V200	P200-S400	200x450
EN BG ETP 150-315-RBC290 ES	355MB	250	CM200-V200	P200-S400	200x450
EN BG ETP 150-315-RAB310 ES	355LB	315	CM200-V200	P200-S400	200x450
EN BG ETP 150-315-RAB315 ES	355LB	315	CM200-V200	P200-S400	200x450

IDROFIRE BG ETP

DIMENSIONI DIMENSIONS

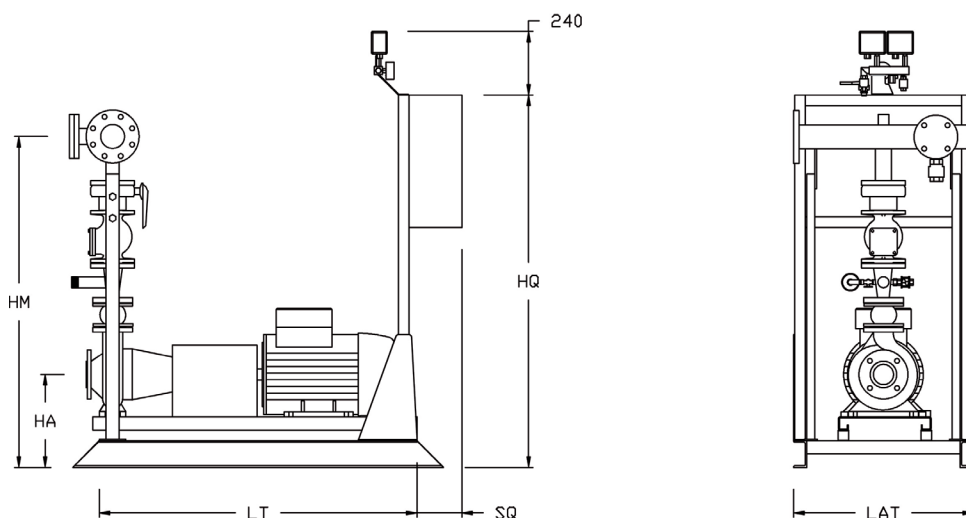

MODELLO GRUPPO	MANDATA		ASPIRAZIONE		HA	HM	LAT	LT	HQ	SQ
	KIT VLV	collettore	STB	STB						
MODEL GROUP	DELIVERY		SUCTION		HA	HM	LAT	LT	HQ	SQ
BG ETP	valves kit	manifold	posit. head	posit. head	mm	mm	mm	mm	mm	mm
EN BG ETP 32-200-NC ES	40	DN80-F50	65	80	370	1243	700	1100	1400	200
EN BG ETP 32-200-NB ES	40	DN80-F50	65	80	370	1243	700	1100	1400	200
EN BG ETP 32-200-NA ES	40	DN80-F50	80	80	370	1243	700	1100	1400	200
EN BG ETP 32-250-E ES	40	DN80-F50	80	100	390	1308	700	1100	1400	200
EN BG ETP 32-250-225 EC	40	DN80-F50	80	100	390	1308	700	1100	1400	200
EN BG ETP 32-250-235 EC	40	DN80-F50	80	100	390	1308	700	1100	1400	200
EN BG ETP 32-250-245 EC	40	DN80-F50	80	100	390	1308	700	1100	1400	200
EN BG ETP 32-250-B ES	50	DN80-F50	100	100	390	1338	700	1300	1400	200
EN BG ETP 32-250-255 EC	40	DN80-F50	80	100	390	1308	700	1100	1400	200
EN BG ETP 32-250-264 EC	40	DN80-F50	80	100	390	1308	700	1100	1400	200
EN BG ETP 32-250-A ES	50	DN80-F50	100	100	434	1382	700	1300	1400	200
EN BG ETP 40-200-185 EC	50	DN80-F50	80	100	370	1273	700	1100	1400	200
EN BG ETP 40-200-195 EC	50	DN80-F50	80	100	370	1273	700	1100	1400	200
EN BG ETP 40-200-205 EC	50	DN80-F50	100	100	370	1273	700	1100	1400	200
EN BG ETP 40-200-214 EC	50	DN80-F50	100	100	370	1273	700	1100	1400	200
EN BG ETP 40-200-NA ES	50	DN80-F50	100	100	395	1298	700	1100	1400	200
EN BG ETP 40-250-225 EC	50	DN80-F50	100	125	390	1338	700	1100	1400	200
EN BG ETP 40-250-235 EC	50	DN80-F50	100	125	390	1338	700	1100	1400	200
EN BG ETP 40-250-245 EC	50	DN80-F50	100	125	390	1338	700	1300	1400	200
EN BG ETP 40-250-255 EC	50	DN80-F50	100	125	390	1338	700	1300	1400	200
EN BG ETP 40-250-264 EC	50	DN80-F50	100	125	434	1382	700	1300	1400	200
EN BG ETP 40-315-RB300 ES	65	DN80-F50	100	125	445	1461	800	1600	1400	200
EN BG ETP 40-315-RAB308 ES	65	DN80-F50	100	125	445	1461	800	1600	1400	200
EN BG ETP 40-315-RAB315 ES	65	DN80-F50	100	125	445	1461	900	1800	1400	200
EN BG ETP 50-160-174 EC	65	DN80-F50	150	150	395	1351	700	1100	1400	200
EN BG ETP 50-200-185 EC	65	DN80-F50	125	125	370	1346	700	1100	1400	200
EN BG ETP 50-200-195 EC	65	DN80-F50	125	125	395	1371	700	1100	1400	200
EN BG ETP 50-200-C ES	65	DN80-F50	125	125	370	1346	700	1100	1400	200
EN BG ETP 50-200-B ES	65	DN80-F50	100	125	395	1371	700	1100	1400	200
EN BG ETP 50-200-205 EC	65	DN80-F50	125	125	388	1364	700	1100	1400	200
EN BG ETP 50-200-A ES	65	DN80-F50	125	125	395	1371	700	1100	1400	200
EN BG ETP 50-200-214 EC	65	DN80-F50	125	125	388	1364	700	1100	1400	200
EN BG ETP 50-200-NB ES	65	DN80-F50	125	150	380	1356	700	1100	1400	200
EN BG ETP 50-200-NA ES	65	DN80-F50	150	150	434	1410	700	1300	1400	200
EN BG ETP 50-250-225 EC	65	DN80-F50	125	125	390	1391	700	1100	1400	200
EN BG ETP 50-250-235 EC	65	DN80-F50	125	125	434	1435	700	1300	1400	200

IDROFIRE BG ETP

DIMENSIONI DIMENSIONS

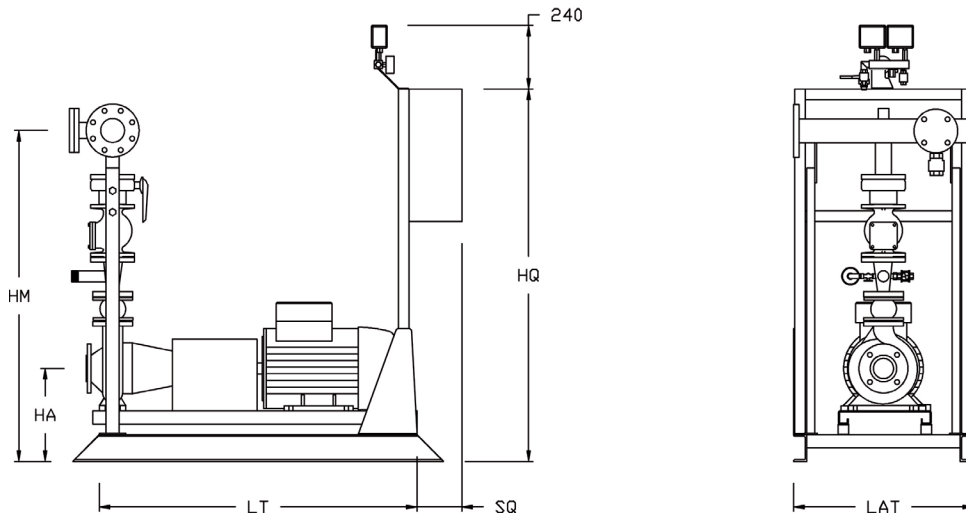

MODELLO GRUPPO	MANDATA		ASPIRAZIONE		HA	HM	LAT	LT	HQ	SQ
	KIT VLV	collettore	STB	STB						
	DELIVERY valves kit	manifold	SUCTION posit. head	posit. head						
BG ETP	DN	DN	DN	DN	mm	mm	mm	mm	mm	mm
EN BG ETP 50-250-245 EC	65	DN80-F50	125	125	434	1435	700	1300	1400	200
EN BG ETP 50-250-255 EC	65	DN80-F50	125	125	400	1401	700	1300	1400	200
EN BG ETP 50-250-264 EC	65	DN80-F50	125	125	400	1401	700	1300	1400	200
EN BG ETP 50-250-NA ES	65	DN80-F50	150	150	400	1401	700	1300	1400	200
EN BG ETP 50-315-274 EC	65	DN80-F50	125	125	445	1501	800	1600	1400	200
EN BG ETP 50-315-291 EC	65	DN80-F50	125	125	445	1501	900	1800	1400	200
EN BG ETP 50-315-308 EC	65	DN80-F50	125	125	450	1506	900	1800	1400	300
EN BG ETP 65-200-185 EC	100	DN125-F80	200	200	390	1512	700	1300	1400	200
EN BG ETP 65-200-NA ES	100	DN125-F80	200	200	400	1522	700	1300	1400	200
EN BG ETP 65-200-195 EC	100	DN125-F80	200	200	434	1556	700	1300	1400	200
EN BG ETP 65-200-205 EC	100	DN125-F80	200	200	400	1522	700	1300	1400	200
EN BG ETP 65-200-214 EC	100	DN125-F80	200	200	400	1522	700	1300	1400	200
EN BG ETP 65-250-225 EC	100	DN125-F80	200	200	420	1567	700	1300	1400	200
EN BG ETP 65-250-NB ES	80	DN100-F80	150	150	420	1488	700	1300	1400	200
EN BG ETP 65-250-235 EC	100	DN125-F80	200	200	420	1567	700	1300	1400	200
EN BG ETP 65-250-245 EC	100	DN125-F80	200	200	420	1567	800	1600	1400	200
EN BG ETP 65-250-255 EC	100	DN125-F80	200	200	420	1567	900	1800	1400	200
EN BG ETP 65-250-NOA ES	100	DN125-F80	200	200	420	1567	800	1600	1400	200
EN BG ETP 65-250-264 EC	100	DN125-F80	200	200	420	1567	900	1800	1400	200
EN BG ETP 65-250-N0 ES	100	DN125-F80	150	200	420	1567	900	1800	1400	200
EN BG ETP 65-315-RCD273 ES	100	DN125-F80	200	200	445	1622	900	1800	1400	200
EN BG ETP 65-315-RBC282 ES	100	DN125-F80	200	200	450	1627	900	1800	1400	300
EN BG ETP 65-315-291 EC	100	DN125-F80	200	200	450	1627	1100	2000	1400	300
EN BG ETP 65-315-308 EC	100	DN125-F80	200	200	555	1732	1100	2300	1400	300
EN BG ETP 80-200-195 EC	125	DN150-F100	250	250	400	1630	700	1300	1400	200
EN BG ETP 80-200-205 EC	125	DN150-F100	250	250	400	1630	700	1300	1400	200
EN BG ETP 80-200-214 EC	125	DN150-F100	250	250	400	1630	800	1600	1400	200
EN BG ETP 80-250-225 EC	125	DN150-F100	200	250	420	1680	800	1600	1400	200
EN BG ETP 80-250-235 EC	125	DN150-F100	200	250	420	1680	900	1800	1400	200
EN BG ETP 80-250-245 EC	125	DN150-F100	250	250	420	1680	900	1800	1400	200
EN BG ETP 80-250-255 EC	125	DN150-F100	250	250	450	1710	900	1800	1400	300
EN BG ETP 80-250-264 EC	125	DN150-F100	250	250	450	1710	900	1800	1400	300
EN BG ETP 80-250-A ES	125	DN150-F100	200	250	555	1815	1100	2300	1400	300
EN BG ETP 100-200-195 EC	150	DN200-F125	250	300	420	1761	700	1300	1400	200
EN BG ETP 100-200-205 EC	150	DN200-F125	250	300	420	1761	900	1800	1400	200
EN BG ETP 100-200-214 EC	150	DN200-F125	250	300	420	1761	900	1800	1400	200

IDROFIRE BG ETP

DIMENSIONI DIMENSIONS

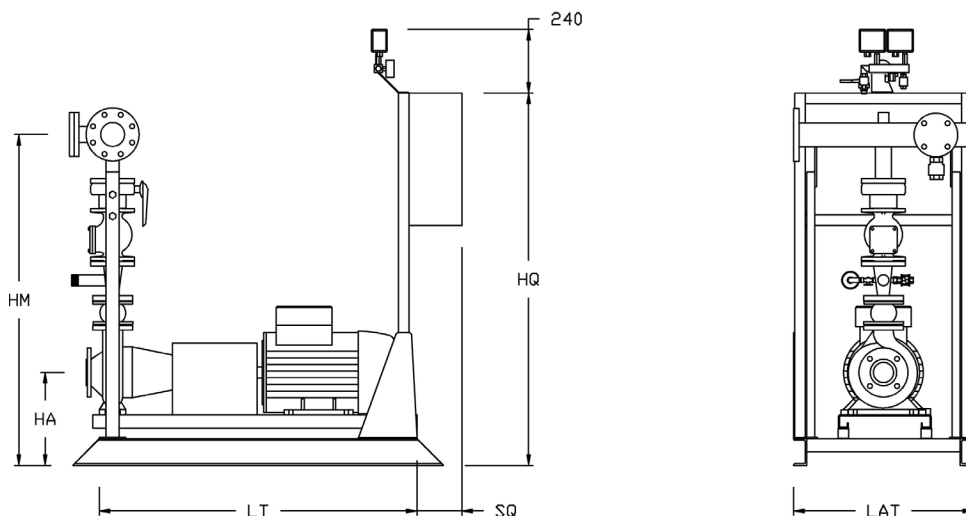

MODELLO GRUPPO	MANDATA		ASPIRAZIONE		HA	HM	LAT	LT	HQ	SQ
	KIT VLV	collettore	STB	STB						
MODEL GROUP	DELIVERY		SUCTION		HA	HM	LAT	LT	HQ	SQ
BG ETP	valves kit	manifold	posit. head	posit. head	mm	mm	mm	mm	mm	mm
EN BG ETP 100-250-225 EC	150	DN200-F125	300	300	450	1791	900	1800	1400	300
EN BG ETP 100-250-235 EC	150	DN200-F125	300	300	450	1791	900	1800	1400	300
EN BG ETP 100-250-245 EC	150	DN200-F125	300	300	450	1791	1100	2000	1400	300
EN BG ETP 100-250-255 EC	150	DN200-F125	300	350	555	1896	1100	2300	1400	300
EN BG ETP 100-250-264 EC	150	DN200-F125	300	350	555	1896	1100	2300	1400	300
EN BG ETP 100-315-291 EC	150	DN200-F125	250	250	555	1931	1100	2300	1400	300
EN BG ETP 100-315-RBC292 ES	150	DN200-F125	300	300	555	1931	1100	2300	1400	300
EN BG ETP 100-315-RBC296 ES	150	DN200-F125	300	300	575	1951	1100	2300	1400	300
EN BG ETP 100-315-RBC308 ES	150	DN200-F125	300	300	575	1951	1100	2300	1400	300
EN BG ETP 100-315-308 EC	150	DN200-F125	300	300	555	1931	1100	2300	1400	300
EN BG ETP 125-200-205 EC	150	DN200-F125	300	350	470	1881	900	1800	1400	300
EN BG ETP 125-200-214 EC	150	DN200-F125	350	350	470	1881	900	1800	1400	300
EN BG ETP 125-250-RC ES	150	DN200-F125	300	350	470	1921	1100	2000	1400	300
EN BG ETP 125-250-RB ES	150	DN200-F125	300	350	555	2006	1100	2300	1400	300
EN BG ETP 125-250-RAB ES	150	DN200-F125	350	350	575	2026	1100	2300	1400	300
EN BG ETP 125-250-250 EC	150	DN200-F125	300	350	555	2006	1100	2300	1400	300
EN BG ETP 125-250-264 EC	150	DN200-F125	300	350	555	2006	1100	2300	1400	300
EN BG ETP 125-315-RBC287 ES	150	DN200-F125	250	350	585	2036	1100	2300	1400	300
EN BG ETP 125-315-RCD295 ES	150	DN200-F125	250	350	595	2046	1100	2300	1400	300
EN BG ETP 125-250-278 EC	150	DN200-F125	350	400	575	2026	1100	2300	1400	300
EN BG ETP 125-315-RBC302 ES	150	DN200-F125	300	350	595	2046	1100	2300	1400	370
EN BG ETP 150-315-RC257 ES	200	DN250-F200	400	400	595	2252	1100	2300	1400	300
EN BG ETP 150-315-RC266 ES	200	DN250-F200	400	400	595	2252	1100	2300	1400	300
EN BG ETP 150-315-RCD280 ES	200	DN250-F200	300	350	595	2252	1100	2300	1400	370
EN BG ETP 150-315-RC290 ES	200	DN250-F200	400	450	635	2292	1300	2500	1400	370
EN BG ETP 150-315-RBC284 ES	200	DN250-F200	400	450	595	2252	1100	2300	1400	370
EN BG ETP 150-315-RBC290 ES	200	DN250-F200	400	450	635	2292	1300	2500	1400	370
EN BG ETP 150-315-RAB310 ES	200	DN250-F200	400	450	635	2292	1300	2500	1400	370
EN BG ETP 150-315-RAB315 ES	200	DN250-F200	400	450	635	2292	1300	2500	1400	370

IDROFIRE BG P1M

N.1 MOTOPOMPA DI SERVIZIO + PILOTA
NR.1 MAIN DIESEL MOTOR PUMP + JOCKEY PUMP

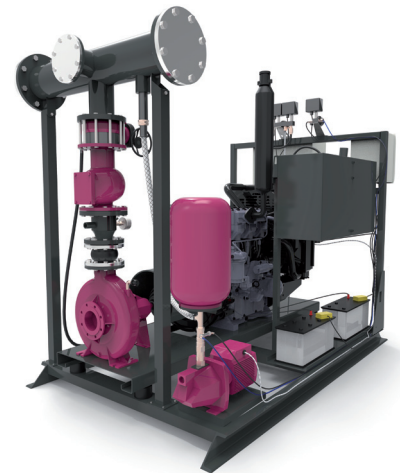

ELENCO COMPONENTI COMPONENT LIST

- | | |
|---|--|
| <ol style="list-style-type: none"> 1. Motopompa Diesel di servizio accoppiata mediante giunto spaziatore completo di protezione coprigiunto 2. Elettropompa pilota 3. Valvola di ritegno a clapet 4. Valvola di intercettazione lucchettabile 5. Valvola di ritegno 6. Valvola di intercettazione a sfera con leva 7. Collettore di mandata reversibile completo di flangia cieca 8. Derivazione per collettore di prova di portata 9. Predisposizione per kit sprinkler 10. Kit avviamento per pompe principali composto da 2 pressostati 2-14 bar con pulsante di prova integrato, 1 manometro 0-16 bar e circuito by-pass 11. Kit avviamento per pompa pilota composto da 1 pressostato con pulsante di prova integrato, 1 manometro 12. Quadri elettrici di comando (uno per ogni pompa) 13. Mano-vuotometro con porta-manometro e rubinetto provvisto di flangia per controllo 14. Kit diaframma di ricircolo completo di indicatore visivo di flusso 15. Manometro 0-16 bar 16. Serbatoio Autoclave 24 lt PN16 17. Giunti antivibranti in gomma 18. Giunto di compensazione in gomma 19. Serbatoio gasolio per motore Diesel 20. Telaio | <ol style="list-style-type: none"> 1. Main Diesel engine pump coupled with coupling joint between motor and pump with spacing protected by carter butt strap 2. Jockey electric pump 3. Swing Check Valve ("Clapet" Valve) 4. Shut-off valve lockable 5. Check valve 6. Ball valve with level 7. Reversible delivery manifold with blind flange 8. Shunt for flow meter 9. Predisposition for sprinkler kit 10. Starting kit for main pump composed by 2 pressure switch 2-14 bar with integrated test button, 1 pressure gauge 0-16 bar and by-pass circuit 11. Starting kit for jockey electric pump composed by 1 pressure switch with integrated test button, 1 pressure gauge 12. Electrical control panels (one for each pump) 13. Vacuum gauge with gauge holder and cock fitted with flange for control 14. Kit recycling diaphragm complete with visual flow indicator 15. Pressure gauge 0-16 bar 16. Diaphragm pressure vessel 24LT PN16 17. Rubber anti-vibration joints 18. Rubber strain neutralizer 19. Fuel tank for diesel engine 20. Frame |
|---|--|

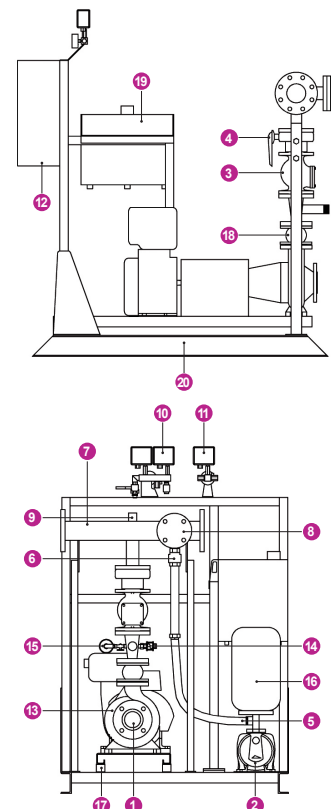

IDROFIRE BG P1M

DATI TECNICI TECHNICAL DATA

MODELLO GRUPPO MODEL GROUP	MOTORE DIESEL DIESEL ENGINE			ELETTROPOMPA PILOTA JOCKEY PUMP		KIT FLUSSIMETRO FLOW METER KIT	KIT ASP. SOTTOBATTENTE pompa principale pompa pilota main pump jockey pump		KIT ASP. SOPRABATTENTE pompa principale SUCTION LIFT KIT main pump
	mod.	kW NA	kW NB	mod.	kW		mod.	mod.	
EN BG P1M 32-200-NC LS+J15	15LD350	4,2	4,6	J15	1,1	CM50-V50	P50-S65	1"	50x80
EN BG P1M 32-200-NB LS+J15	15LD440	6,2	6,7	J15	1,1	CM50-V50	P50-S65	1"	50x80
EN BG P1M 32-200-NA LS+J15	15LD500	7,1	7,8	J15	1,1	CM50-V50	P50-S80	1"	50x80
EN BG P1M 32-250-E LS+J3A	12LD477/2	13,6	15	J3A	2,2	CM50-V50	P50-S80	1¼"	50x100
EN BG P1M 32-250-225 LC+J15	12LD477/2	13,6	15	J15	1,1	CM50-V50	P50-S80	1"	50x100
EN BG P1M 32-250-235 LC+J3A	9LD625/2	17,6	18,9	J3A	2,2	CM50-V50	P50-S80	1¼"	50x100
EN BG P1M 32-250-245 LC+J3A	9LD625/2	17,6	18,9	J3A	2,2	CM50-V50	P50-S80	1¼"	50x100
EN BG P1M 32-250-B PS+J3A	LPW 3-09	20,1	22,1	J3A	2,2	CM50-V50	P50-S100	1¼"	50x100
EN BG P1M 32-250-255 LC+J3A	9LD625/2	17,6	18,9	J3A	2,2	CM50-V50	P50-S80	1¼"	50x100
EN BG P1M 32-250-264 PC+J3A	LPW 3-09	20,1	22,1	J3A	2,2	CM50-V50	P50-S80	1¼"	50x100
EN BG P1M 32-250-A LS+J3A	11LD626/3	24	26	J3A	2,2	CM50-V50	P50-S100	1¼"	50x100
EN BG P1M 40-200-185 LC+J15	15LD500	7,1	7,8	J15	1,1	CM50-V50	P65-S80	1"	65x100
EN BG P1M 40-200-195 LC+J15	25LD425	10,4	11,5	J15	1,1	CM50-V50	P65-S80	1"	65x100
EN BG P1M 40-200-205 LC+J15	25LD425	10,4	11,5	J15	1,1	CM50-V50	P65-S100	1"	65x100
EN BG P1M 40-200-214 LC+J15	25LD425	10,4	11,5	J15	1,1	CM50-V50	P65-S100	1"	65x100
EN BG P1M 40-200-NA LS+J3A	12LD477/2	13,6	15	J3A	2,2	CM65-V50	P65-S100	1¼"	65x100
EN BG P1M 40-250-225 LC+J15	9LD625/2	17,6	18,9	J15	1,1	CM65-V50	P65-S100	1"	65x125
EN BG P1M 40-250-235 LC+J3A	9LD625/2	17,6	18,9	J3A	2,2	CM65-V50	P65-S100	1¼"	65x125
EN BG P1M 40-250-245 PC+J3A	LPW 3-09	20,1	22,1	J3A	2,2	CM65-V50	P65-S100	1¼"	65x125
EN BG P1M 40-250-255 PC+J3A	LPW 3-09	20,1	22,1	J3A	2,2	CM65-V50	P65-S100	1¼"	65x125
EN BG P1M 40-250-264 LC+J3A	11LD626/3	24	26	J3A	2,2	CM65-V50	P65-S100	1¼"	65x125
EN BG P1M 40-250-264 PC+J3A	LPW 4-09	26,8	29,5	J3A	2,2	CM65-V50	P65-S100	1¼"	65x125
EN BG P1M 40-315-RB300 VS+V18	D703LTE0	48	53	V18	2,2	CM65 - V50	P65-S100	1½"	65x125
EN BG P1M 40-315-RAB308 VS+V18	D703LTE0	48	53	V18	2,2	CM65 - V50	P65-S100	1½"	65x125
EN BG P1M 40-315-RAB315 VS+V18	D703LTE0	48	53	V18	2,2	CM65 - V50	P65-S100	1½"	65x125
EN BG P1M 50-160-174 LC+J15	12LD477/2	13,6	15	J15	1,1	CM65 - V50	P65-S150	1"	65x150
EN BG P1M 50-200-185 LC+J15	25LD425	10,4	11,5	J15	1,1	CM65-V50	P65-S125	1"	65x125
EN BG P1M 50-200-195 LC+J15	12LD477/2	13,6	15	J15	1,1	CM65-V50	P65-S125	1"	65x125
EN BG P1M 50-200-C LS+J15	25LD425	10,4	11,5	J15	1,1	CM65 - V50	P65-S125	1"	65x125
EN BG P1M 50-200-B LS+J15	12LD477/2	13,6	15	J15	1,1	CM65 - V50	P65-S100	1"	65x125
EN BG P1M 50-200-205 LC+J15	9LD625/2	17,6	18,9	J15	1,1	CM65-V50	P65-S125	1"	65x125
EN BG P1M 50-200-A LS+J3A	12LD477/2	13,6	15	J3A	2,2	CM65-V50	P65-S125	1¼"	65x125
EN BG P1M 50-200-214 LC+J15	9LD625/2	17,6	18,9	J15	1,1	CM65 - V50	P65-S125	1"	65x125
EN BG P1M 50-200-NB PS+J15	LPW 3-09	20,1	22,1	J15	1,1	CM65 - V50	P65-S125	1"	65x150
EN BG P1M 50-200-NA LS+J3A	11LD626/3	24	26	J3A	2,2	CM65 - V50	P65-S150	1¼"	65x150
EN BG P1M 50-200-NA PS+J3A	LPW 4-09	26,8	29,5	J3A	2,2	CM65 - V50	P65-S150	1¼"	65x150
EN BG P1M 50-250-225 PC+J3A	LPW 3-09	20,1	22,1	J3A	2,2	CM65-V50	P65-S125	1¼"	65x125
EN BG P1M 50-250-235 LC+J3A	11LD626/3	24	26	J3A	2,2	CM65-V50	P65-S125	1¼"	65x125
EN BG P1M 50-250-235 PC+J3A	LPW 4-09	26,8	29,5	J3A	2,2	CM65-V50	P65-S125	1¼"	65x125
EN BG P1M 50-250-245 LC+J3A	11LD626/3	24	26	J3A	2,2	CM65 - V50	P65-S125	1¼"	65x125
EN BG P1M 50-250-245 PC+J3A	LPW 4-09	26,8	29,5	J3A	2,2	CM65 - V50	P65-S125	1¼"	65x125
EN BG P1M 50-250-255 VC+J3A	D703LE0	33	37	J3A	2,2	CM65 - V50	P65-S125	1¼"	65x125
EN BG P1M 50-250-264 VC+J3A	D703LE0	33	37	J3A	2,2	CM65 - V50	P65-S125	1¼"	65x125
EN BG P1M 50-250-264 PC+J3A	LPWT 4-09	37,5	40,2	J3A	2,2	CM65 - V50	P65-S125	1¼"	65x125
EN BG P1M 50-250-NA VS+J3A	D703LE0	33	37	J3A	2,2	CM65 - V50	P65-S150	1¼"	65x150
EN BG P1M 50-250-NA PS+J3A	LPWT 4-09	37,5	40,2	J3A	2,2	CM65 - V50	P65-S150	1¼"	65x150
EN BG P1M 50-315-274 VC+V12	D703LTE0	48	53	V12	1,5	CM65-V50	P80-S125	1½"	80x125
EN BG P1M 50-315-291 VC+V18	D703LTE0	48	53	V18	2,2	CM65-V50	P80-S125	1½"	80x125
EN BG P1M 50-315-308 VC+V18	D754TPE2	65	73	V18	2,2	CM65-V50	P80-S125	1½"	80x125
EN BG P1M 65-200-185 PC+J15	LPW 3-09	20,1	22,1	J15	1,1	CM100-V80	P80-S200	1"	80x200
EN BG P1M 65-200-NA VS+J3A	D703LE0	33	37	J3A	2,2	CM100-V80	P80-S200	1¼"	80x200
EN BG P1M 65-200-195 LC+J15	11LD626/3	24	26	J15	1,1	CM100-V80	P80-S200	1"	80x200
EN BG P1M 65-200-195 PC+J15	LPW 4-09	26,8	29,5	J15	1,1	CM100-V80	P80-S200	1"	80x200
EN BG P1M 65-200-205 PC+J15	LPW 4-09	26,8	29,5	J15	1,1	CM100-V80	P80-S200	1"	80x200
EN BG P1M 65-200-214 VC+J3A	D703LE0	33	37	J3A	2,2	CM100-V100	P80-S200	1¼"	80x200
EN BG P1M 65-200-214 PC+J3A	LPWT 4-09	37,5	40,2	J3A	2,2	CM100-V100	P80-S200	1¼"	80x200
EN BG P1M 65-250-225 VC+J3A	D703LE0	33	37	J3A	2,2	CM100-V80	P80-S200	1¼"	80x200
EN BG P1M 65-250-225 PC+J3A	LPWT 4-09	37,5	40,2	J3A	2,2	CM100-V80	P80-S200	1¼"	80x200

IDROFIRE BG P1M

DATI TECNICI TECHNICAL DATA

MODELLO GRUPPO	MOTORE DIESEL			ELETTROPOMPA PILOTA		KIT FLUSSIMETRO	KIT ASP. SOTTOBATTENTE		KIT ASP. SOPRABATTENTE
	DIESEL ENGINE			JOCKEY PUMP		FLOW METER KIT	pompa principale	pompa pilota	pompa principale
							POSITIVE HEAD KIT		SUCTION LIFT KIT
MODEL GROUP							main pump	jockey pump	main pump
BG P1M	mod.	kW NA	kW NB	mod.	kW	mod.	mod.	DN	mod.
EN BG P1M 65-250-NB VS+J3A	D703LE0	33	37	J3A	2,2	CM80-V80	P80-S150	1¼"	80x150
EN BG P1M 65-250-NB PS+J3A	LPWT 4-09	37,5	40,2	J3A	2,2	CM80-V80	P80-S150	1¼"	80x150
EN BG P1M 65-250-235 VC+J3A	D703LTE0	48	53	J3A	2,2	CM100-V80	P80-S200	1¼"	80x200
EN BG P1M 65-250-235 PC+J3A	LPWT 4-09	37,5	40,2	J3A	2,2	CM100-V80	P80-S200	1¼"	80x200
EN BG P1M 65-250-245 VC+J3A	D703LTE0	48	53	J3A	2,2	CM100-V80	P80-S200	1¼"	80x200
EN BG P1M 65-250-255 VC+J3A	D703LTE0	48	53	J3A	2,2	CM100-V80	P80-S200	1¼"	80x200
EN BG P1M 65-250-NOA VS+J3A	D703LTE0	48	53	J3A	2,2	CM100-V80	P80-S200	1¼"	80x200
EN BG P1M 65-250-264 VC+J3A	D754TPE2	65	73	J3A	2,2	CM100-V80	P80-S200	1¼"	80x200
EN BG P1M 65-250-NO VS+J3A	D703LTE0	48	53	J3A	2,2	CM100-V80	P80-S150	1¼"	80x200
EN BG P1M 65-315-RCD273 VS+V12	D754TPE2	65	73	V12	1,5	CM100-V80	P80-S200	1½"	80x200
EN BG P1M 65-315-RBC282 VS+V18	D754TPE2	65	73	V18	2,2	CM100-V80	P80-S200	1½"	80x200
EN BG P1M 65-315-291 VC+V18	D756IPE2	100	110	V18	2,2	CM100-V80	P80-S200	1½"	80x200
EN BG P1M 65-315-308 IC+V18	N45 MNT F41	130,5	145	V18	2,2	CM100-V80	P80-S200	1½"	80x200
EN BG P1M 80-200-195 VC+J15	D703LE0	33	37	J15	1,1	CM125-V100	P100-S250	1"	100x250
EN BG P1M 80-200-195 PC+J15	LPWT 4-09	37,5	40,2	J15	1,1	CM125-V100	P100-S250	1"	100x250
EN BG P1M 80-200-205 VC+J15	D703LTE0	48	53	J15	1,1	CM125-V100	P100-S250	1"	100x250
EN BG P1M 80-200-205 PC+J15	LPWT 4-09	37,5	40,2	J15	1,1	CM125-V100	P100-S250	1"	100x250
EN BG P1M 80-200-214 VC+J3A	D703LTE0	48	53	J3A	2,2	CM125-V125	P100-S250	1¼"	100x250
EN BG P1M 80-250-225 VC+J3A	D703LTE0	48	53	J3A	2,2	CM100-V100	P100-S200	1¼"	100x250
EN BG P1M 80-250-235 VC+J3A	D703LTE0	48	53	J3A	2,2	CM125-V100	P100-S200	1¼"	100x250
EN BG P1M 80-250-245 VC+J3A	D754TPE2	65	73	J3A	2,2	CM125-V100	P100-S250	1¼"	100x250
EN BG P1M 80-250-255 VC+J3A	D754TPE2	65	73	J3A	2,2	CM125-V100	P100-S250	1¼"	100x250
EN BG P1M 80-250-264 VC+J3A	D756IPE2	100	110	J3A	2,2	CM125-V125	P100-S250	1¼"	100x250
EN BG P1M 80-250-A VS+J3A	D756IPE2	100	110	J3A	2,2	CM125-V100	P100-S200	1¼"	100x250
EN BG P1M 100-200-195 VC+J15	D703LTE0	48	53	J15	1,1	CM125-V125	P125-S250	1"	125x300
EN BG P1M 100-200-195 PC+J15	LPWT 4-09	37,5	40,2	J15	1,1	CM125-V125	P125-S250	1"	125x300
EN BG P1M 100-200-205 VC+J15	D703LTE0	48	53	J15	1,1	CM125-V125	P125-S250	1"	125x300
EN BG P1M 100-200-214 VC+J3A	D754TPE2	65	73	J3A	2,2	CM125-V125	P125-S250	1¼"	125x300
EN BG P1M 100-250-225 VC+J3A	D754TPE2	65	73	J3A	2,2	CM125-V125	P125-S300	1¼"	125x300
EN BG P1M 100-250-235 VC+J3A	D756IPE2	100	110	J3A	2,2	CM125-V125	P125-S300	1¼"	125x300
EN BG P1M 100-250-245 VC+J3A	D756IPE2	100	110	J3A	2,2	CM125-V125	P125-S300	1¼"	125x300
EN BG P1M 100-250-255 IC+J3A	N45 MNT F41	130,5	145	J3A	2,2	CM125-V125	P125-S300	1¼"	125x350
EN BG P1M 100-250-264 IC+J3A	N45 MNT F41	130,5	145	J3A	2,2	CM125-V125	P125-S300	1¼"	125x350
EN BG P1M 100-315-291 IC+V18	N45 MNT F41	130,5	145	V18	2,2	CM125-V125	P150-S250	1½"	150x250
EN BG P1M 100-315-RBC292 IS+V18	N45 MNT F41	130,5	145	V18	2,2	CM125-V125	P125-S300	1½"	125x300
EN BG P1M 100-315-RBC296 IS+V18	N67 MNT F42	178	197	V18	2,2	CM125-V125	P125-S300	1½"	125x300
EN BG P1M 100-315-RBC308 IS+V18	N67 MNT F42	178	197	V18	2,2	CM125-V125	P125-S300	1½"	125x300
EN BG P1M 100-315-308 IC+V18	N45MNT F41	130,5	145	V18	2,2	CM125-V125	P150-S300	1½"	150x300
EN BG P1M 125-200-205 VC+J15	D754TPE2	65	73	J15	1,1	CM200-V200	P150-S300	1"	150x350
EN BG P1M 125-200-214 VC+J15	D756IPE2	100	110	J15	1,1	CM200-V200	P150-S350	1"	150x350
EN BG P1M 125-250-RC VS+J3A	D756IPE2	100	110	J3A	2,2	CM125-V125	P125-S300	1¼"	150x350
EN BG P1M 125-250-RB IS+J3A	N45 MNT F41	130,5	145	J3A	2,2	CM150-V125	P150-S300	1¼"	150x350
EN BG P1M 125-250-RAB IS+J3A	N67 MNT F42	178	197	J3A	2,2	CM150-V125	P150-S350	1¼"	150x350
EN BG P1M 125-250-250 IC+V12	N45 MNT F41	130,5	145	V12	1,1	CM200-V200	P150-S300	1½"	150x350
EN BG P1M 125-250-264 IC+V12	N45 MNT F41	130,5	145	V12	1,1	CM200-V200	P150-S300	1½"	150x350
EN BG P1M 125-315-RBC287 IS+V12	N67 MNT F42	178	197	V12	1,5	CM125-V125	P150-S300	1½"	150x350
EN BG P1M 125-315-RCD295 IS+V18	N67 MNT F42	178	197	V18	2,2	CM125-V125	P150-S300	1½"	150x350
EN BG P1M 125-250-278 IC+V18	N67 MNT F42	178	197	V18	2,2	CM200-V200	P150-S350	1½"	150x400
EN BG P1M 125-315-RBC302 IS+V18	N67 MNT F42	178	197	V18	2,2	CM125-V125	P150-S300	1½"	150x350
EN BG P1M 150-315-RC257 IS+V12	N67 MNT F42	178	197	V12	1,5	CM200-V200	P200-S400	1½"	200x400
EN BG P1M 150-315-RC266 IS+V12	N67 MNT F42	178	197	V12	1,5	CM200-V200	P200-S400	1½"	200x400
EN BG P1M 150-315-RCD280 IS+V12	N67 MNT F42	200	222	V12	1,5	CM200-V200	P200-S300	1½"	200x350
EN BG P1M 150-315-RC290 IS+V18	N67 MNT F40	227	246	V18	2,2	CM200-V200	P200-S400	1½"	200x450
EN BG P1M 150-315-RBC284 IS+V18	N67 MNT F42	200	222	V18	2,2	CM200-V200	P200-S400	1½"	200x450
EN BG P1M 150-315-RBC290 IS+V18	N67 MNT F40	227	246	V18	2,2	CM200-V200	P200-S400	1½"	200x450
EN BG P1M 150-315-RAB310 IS+V18	N60 ENTF 40	282	295	V18	2,2	CM200-V200	P200-S400	1½"	200x450
EN BG P1M 150-315-RAB315 IS+V18	N60 ENTF 40	282	295	V18	2,2	CM200-V200	P200-S400	1½"	200x450

IDROFIRE BG P1M

DIMENSIONI DIMENSIONS

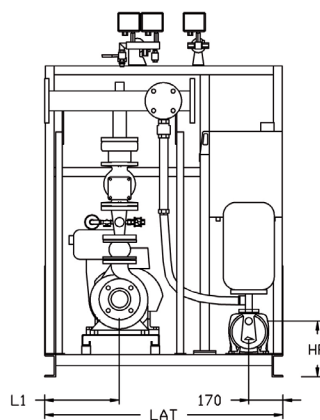
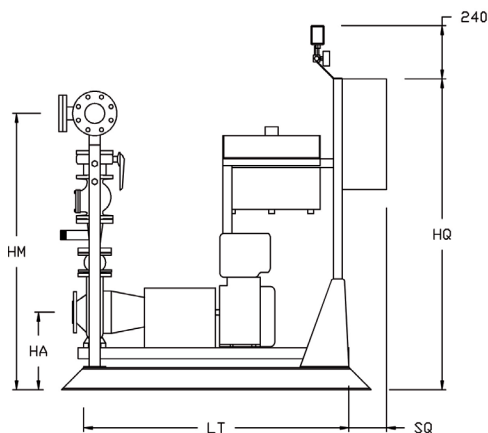

MODELLO GRUPPO	MANDATA		ASPIRAZIONE		PILOTA	HA	HM	LAT	LT	L1	HQ	SQ	HP
	KIT VLV	collettore	STB	STB									
	DELIVERY valves kit	manifold	SUCTION posit. head	posit. head									
MODEL GROUP	DN	DN	DN	DN	DN AxM	mm	mm	mm	mm	mm	mm	mm	mm
EN BG P1M 32-200-NC LS+J15	40	DN80-F50	65	80	1"	370	1243	1000	1100	350	1400	200	277
EN BG P1M 32-200-NB LS+J15	40	DN80-F50	65	80	1"	370	1243	1000	1100	350	1400	200	277
EN BG P1M 32-200-NA LS+J15	40	DN80-F50	80	80	1"	370	1243	1000	1100	350	1400	200	277
EN BG P1M 32-250-E LS+J3A	40	DN80-F50	80	100	1 1/4"	390	1308	1000	1100	350	1400	200	295
EN BG P1M 32-250-225 LC+J15	40	DN80-F50	80	100	1"	390	1308	1000	1100	350	1400	200	277
EN BG P1M 32-250-235 LC+J3A	40	DN80-F50	80	100	1 1/4"	390	1308	1000	1300	350	1400	200	295
EN BG P1M 32-250-245 LC+J3A	40	DN80-F50	80	100	1 1/4"	390	1308	1000	1300	350	1400	200	295
EN BG P1M 32-250-B PS+J3A	50	DN80-F50	100	100	1 1/4"	390	1338	1000	1400	350	1400	200	295
EN BG P1M 32-250-255 LC+J3A	40	DN80-F50	80	100	1 1/4"	390	1308	1000	1300	350	1400	200	295
EN BG P1M 32-250-264 PC+J3A	40	DN80-F50	80	100	1 1/4"	390	1308	1000	1400	350	1400	200	295
EN BG P1M 32-250-A LS+J3A	50	DN80-F50	100	100	1 1/4"	434	1382	1000	1400	350	1400	200	295
EN BG P1M 40-200-185 LC+J15	50	DN80-F50	80	100	1"	370	1273	1000	1100	350	1400	200	277
EN BG P1M 40-200-195 LC+J15	50	DN80-F50	80	100	1"	370	1273	1000	1100	350	1400	200	277
EN BG P1M 40-200-205 LC+J15	50	DN80-F50	100	100	1"	370	1273	1000	1100	350	1400	200	277
EN BG P1M 40-200-214 LC+J15	50	DN80-F50	100	100	1"	370	1273	1000	1100	350	1400	200	277
EN BG P1M 40-200-NA LS+J3A	50	DN80-F50	100	100	1 1/4"	395	1298	1000	1100	350	1400	200	295
EN BG P1M 40-250-225 LC+J15	50	DN80-F50	100	125	1"	390	1338	1000	1300	350	1400	200	277
EN BG P1M 40-250-235 LC+J3A	50	DN80-F50	100	125	1 1/4"	390	1338	1000	1300	350	1400	200	295
EN BG P1M 40-250-245 PC+J3A	50	DN80-F50	100	125	1 1/4"	390	1338	1000	1400	350	1400	200	295
EN BG P1M 40-250-255 PC+J3A	50	DN80-F50	100	125	1 1/4"	390	1338	1000	1400	350	1400	200	295
EN BG P1M 40-250-264 LC+J3A	50	DN80-F50	100	125	1 1/4"	434	1382	1000	1400	350	1400	200	295
EN BG P1M 40-250-264 PC+J3A	50	DN80-F50	100	125	1 1/4"	400	1348	1100	1600	400	1400	200	295
EN BG P1M 40-315-RB300 VS+V18	65	DN80-F50	100	125	1 1/2"	445	1461	1100	1600	400	1400	200	181
EN BG P1M 40-315-RAB308 VS+V18	65	DN80-F50	100	125	1 1/2"	445	1461	1100	1600	400	1400	200	181
EN BG P1M 40-315-RAB315 VS+V18	65	DN80-F50	100	125	1 1/2"	445	1461	1100	1600	400	1400	200	181
EN BG P1M 50-160-174 LC+J15	65	DN80-F50	150	150	1"	395	1351	1000	1100	350	1400	200	277
EN BG P1M 50-200-185 LC+J15	65	DN80-F50	125	125	1"	370	1346	1000	1100	350	1400	200	277
EN BG P1M 50-200-195 LC+J15	65	DN80-F50	125	125	1"	395	1371	1000	1100	350	1400	200	277
EN BG P1M 50-200-C LS+J15	65	DN80-F50	125	125	1"	370	1346	1000	1100	350	1400	200	277
EN BG P1M 50-200-B LS+J15	65	DN80-F50	100	125	1"	395	1371	1000	1100	350	1400	200	277
EN BG P1M 50-200-205 LC+J15	65	DN80-F50	125	125	1"	388	1364	1000	1300	350	1400	200	277
EN BG P1M 50-200-A LS+J3A	65	DN80-F50	125	125	1 1/4"	395	1371	1000	1100	350	1400	200	295
EN BG P1M 50-200-214 LC+J15	65	DN80-F50	125	125	1"	388	1364	1000	1300	350	1400	200	277
EN BG P1M 50-200-NB PS+J15	65	DN80-F50	125	150	1"	380	1356	1000	1400	350	1400	200	277
EN BG P1M 50-200-NA LS+J3A	65	DN80-F50	150	150	1 1/4"	434	1410	1000	1400	350	1400	200	295
EN BG P1M 50-200-NA PS+J3A	65	DN80-F50	150	150	1 1/4"	390	1366	1100	1600	400	1400	200	295
EN BG P1M 50-250-225 PC+J3A	65	DN80-F50	125	125	1 1/4"	390	1391	1000	1400	350	1400	200	295
EN BG P1M 50-250-235 LC+J3A	65	DN80-F50	125	125	1 1/4"	434	1435	1000	1400	350	1400	200	295
EN BG P1M 50-250-235 PC+J3A	65	DN80-F50	125	125	1 1/4"	400	1401	1100	1600	400	1400	200	295

IDROFIRE BG P1M

DIMENSIONI DIMENSIONS

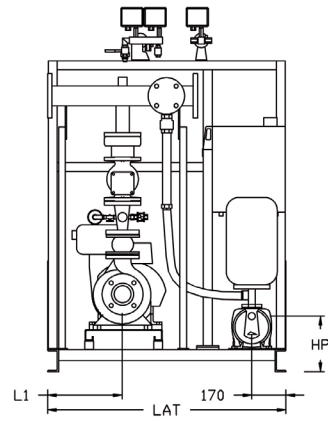
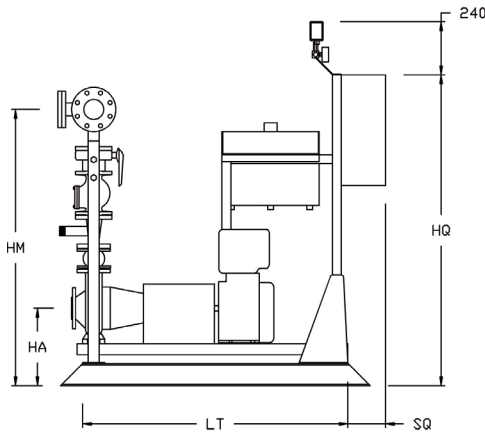

MODELLO GRUPPO	MANDATA		ASPIRAZIONE		PILOTA	HA	HM	LAT	LT	L1	HQ	SQ	HP
	KIT VLV	collettore	STB	STB									
	DELIVERY valves kit	manifold	SUCTION posit. head	posit. head									
MODEL GROUP	DN	DN	DN	DN	DN AxM	mm	mm	mm	mm	mm	mm	mm	mm
EN BG P1M 50-250-245 LC+J3A	65	DN80-F50	125	125	1¼"	434	1435	1000	1400	350	1400	200	295
EN BG P1M 50-250-245 PC+J3A	65	DN80-F50	125	125	1¼"	400	1401	1100	1600	400	1400	200	295
EN BG P1M 50-250-255 VC+J3A	65	DN80-F50	125	125	1¼"	400	1401	1100	1600	400	1400	200	295
EN BG P1M 50-250-264 VC+J3A	65	DN80-F50	125	125	1¼"	400	1401	1100	1600	400	1400	200	295
EN BG P1M 50-250-264 PC+J3A	65	DN80-F50	125	125	1¼"	400	1401	1100	1600	400	1400	200	295
EN BG P1M 50-250-NA VS+J3A	65	DN80-F50	150	150	1¼"	400	1401	1100	1600	400	1400	200	295
EN BG P1M 50-250-NA PS+J3A	65	DN80-F50	150	150	1¼"	400	1401	1100	1600	400	1400	200	295
EN BG P1M 50-315-274 VC+V12	65	DN80-F50	125	125	1½"	445	1501	1100	1600	400	1400	200	181
EN BG P1M 50-315-291 VC+V18	65	DN80-F50	125	125	1½"	445	1501	1100	1600	400	1400	200	181
EN BG P1M 50-315-308 VC+V18	65	DN80-F50	125	125	1½"	450	1506	1200	1800	450	1400	200	181
EN BG P1M 65-200-185 PC+J15	100	DN125-F80	200	200	1"	390	1512	1000	1400	350	1400	200	277
EN BG P1M 65-200-NA VS+J3A	100	DN125-F80	200	200	1¼"	400	1522	1100	1600	400	1400	200	295
EN BG P1M 65-200-195 LC+J15	100	DN125-F80	200	200	1"	434	1556	1000	1400	350	1400	200	277
EN BG P1M 65-200-195 PC+J15	100	DN125-F80	200	200	1"	400	1522	1100	1600	400	1400	200	277
EN BG P1M 65-200-205 PC+J15	100	DN125-F80	200	200	1"	400	1522	1100	1600	400	1400	200	277
EN BG P1M 65-200-214 VC+J3A	100	DN125-F80	200	200	1¼"	400	1522	1100	1600	400	1400	200	295
EN BG P1M 65-200-214 PC+J3A	100	DN125-F80	200	200	1¼"	400	1522	1100	1600	400	1400	200	295
EN BG P1M 65-250-225 VC+J3A	100	DN125-F80	200	200	1¼"	420	1567	1100	1600	400	1400	200	295
EN BG P1M 65-250-225 PC+J3A	100	DN125-F80	200	200	1¼"	420	1567	1100	1600	400	1400	200	295
EN BG P1M 65-250-NB VS+J3A	80	DN100-F80	150	150	1¼"	420	1488	1100	1600	400	1400	200	295
EN BG P1M 65-250-NB PS+J3A	80	DN100-F80	150	150	1¼"	420	1488	1100	1600	400	1400	200	295
EN BG P1M 65-250-235 VC+J3A	100	DN125-F80	200	200	1¼"	420	1567	1100	1600	400	1400	200	295
EN BG P1M 65-250-235 PC+J3A	100	DN125-F80	200	200	1¼"	420	1567	1100	1600	400	1400	200	295
EN BG P1M 65-250-245 VC+J3A	100	DN125-F80	200	200	1¼"	420	1567	1100	1600	400	1400	200	295
EN BG P1M 65-250-255 VC+J3A	100	DN125-F80	200	200	1¼"	420	1567	1100	1600	400	1400	200	295
EN BG P1M 65-250-NOA VS+J3A	100	DN125-F80	200	200	1¼"	420	1567	1100	1600	400	1400	200	295
EN BG P1M 65-250-264 VC+J3A	100	DN125-F80	200	200	1¼"	420	1567	1200	1800	450	1400	200	295
EN BG P1M 65-250-NO VS+J3A	100	DN125-F80	150	200	1¼"	420	1567	1100	1600	400	1400	200	295
EN BG P1M 65-315-RCD273 VS+V12	100	DN125-F80	200	200	1½"	445	1622	1200	1800	450	1400	200	181
EN BG P1M 65-315-RBC282 VS+V18	100	DN125-F80	200	200	1½"	450	1627	1200	1800	450	1400	200	181
EN BG P1M 65-315-291 VC+V18	100	DN125-F80	200	200	1½"	450	1627	1200	2000	450	1400	200	181
EN BG P1M 65-315-308 IC+V18	100	DN125-F80	200	200	1½"	555	1732	1400	2000	550	1400	200	181
EN BG P1M 80-200-195 VC+J15	125	DN150-F100	250	250	1"	400	1630	1100	1600	400	1400	200	277
EN BG P1M 80-200-195 PC+J15	125	DN150-F100	250	250	1"	400	1630	1100	1600	400	1400	200	277
EN BG P1M 80-200-205 VC+J15	125	DN150-F100	250	250	1"	400	1630	1100	1600	400	1400	200	277
EN BG P1M 80-200-205 PC+J15	125	DN150-F100	250	250	1"	400	1630	1100	1600	400	1400	200	277
EN BG P1M 80-200-214 VC+J3A	125	DN150-F100	250	250	1¼"	400	1630	1100	1600	400	1400	200	295
EN BG P1M 80-250-225 VC+J3A	125	DN150-F100	200	250	1¼"	420	1680	1100	1600	400	1400	200	295
EN BG P1M 80-250-235 VC+J3A	125	DN150-F100	200	250	1¼"	420	1680	1100	1600	400	1400	200	295

IDROFIRE BG P1M

DIMENSIONI DIMENSIONS

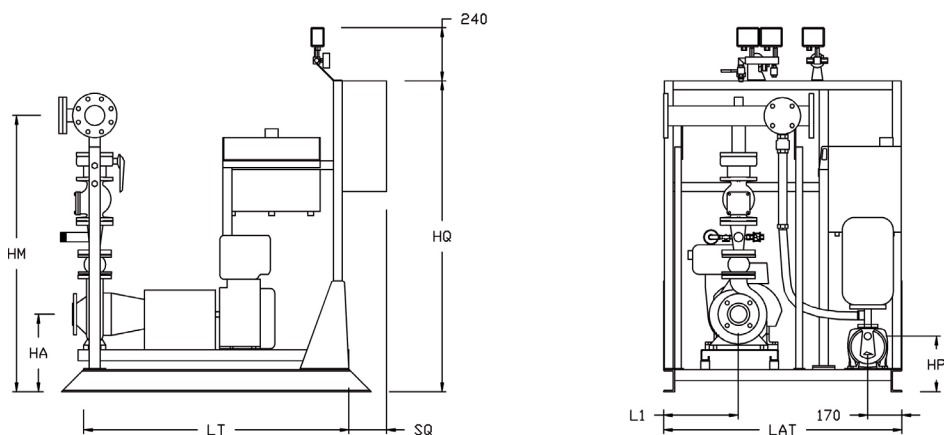

MODELLO GRUPPO	MANDATA		ASPIRAZIONE		PILOTA	HA	HM	LAT	LT	L1	HQ	SQ	HP
	KIT VLV	collettore	STB	STB									
	DELIVERY valves kit	manifold	SUCTION posit. head	posit. head									
MODEL GROUP	DN	DN	DN	DN	DN AxM	mm	mm	mm	mm	mm	mm	mm	mm
EN BG P1M 80-250-245 VC+J3A	125	DN150-F100	250	250	1¼"	420	1680	1200	1800	450	1400	200	295
EN BG P1M 80-250-255 VC+J3A	125	DN150-F100	250	250	1¼"	450	1710	1200	1800	450	1400	200	295
EN BG P1M 80-250-264 VC+J3A	125	DN150-F100	250	250	1¼"	450	1710	1200	2000	450	1400	200	295
EN BG P1M 80-250-A VS+J3A	125	DN150-F100	200	250	1¼"	555	1815	1400	2000	550	1400	200	295
EN BG P1M 100-200-195 VC+J15	150	DN200-F125	250	300	1"	420	1761	1100	1600	400	1400	200	277
EN BG P1M 100-200-195 PC+J15	150	DN200-F125	250	300	1"	420	1761	1100	1600	400	1400	200	277
EN BG P1M 100-200-205 VC+J15	150	DN200-F125	250	300	1"	420	1761	1100	1600	400	1400	200	277
EN BG P1M 100-200-214 VC+J3A	150	DN200-F125	250	300	1¼"	420	1761	1200	1800	450	1400	200	295
EN BG P1M 100-250-225 VC+J3A	150	DN200-F125	300	300	1¼"	450	1791	1200	1800	450	1400	200	295
EN BG P1M 100-250-235 VC+J3A	150	DN200-F125	300	300	1¼"	450	1791	1200	2000	450	1400	200	295
EN BG P1M 100-250-245 VC+J3A	150	DN200-F125	300	300	1¼"	450	1791	1200	2000	450	1400	200	295
EN BG P1M 100-250-255 IC+J3A	150	DN200-F125	300	350	1¼"	555	1896	1400	2000	550	1400	200	295
EN BG P1M 100-250-264 IC+J3A	150	DN200-F125	300	350	1¼"	555	1896	1400	2000	550	1400	200	295
EN BG P1M 100-315-291 IC+V18	150	DN200-F125	250	250	1½"	555	1931	1400	2000	550	1400	200	181
EN BG P1M 100-315-RBC292 IS+V18	150	DN200-F125	300	300	1½"	555	1931	1400	2000	550	1400	200	181
EN BG P1M 100-315-RBC296 IS+V18	150	DN200-F125	300	300	1½"	575	1951	1400	2000	550	1400	200	181
EN BG P1M 100-315-RBC308 IS+V18	150	DN200-F125	300	300	1½"	575	1951	1400	2300	550	1400	200	181
EN BG P1M 100-315-308 IC+V18	150	DN200-F125	300	300	1½"	555	1931	1400	2000	550	1400	200	181
EN BG P1M 125-200-205 VC+J15	150	DN200-F125	300	350	1"	470	1881	1200	1800	450	1400	200	277
EN BG P1M 125-200-214 VC+J15	150	DN200-F125	350	350	1"	470	1881	1200	2000	450	1400	200	277
EN BG P1M 125-250-RCVS+J3A	150	DN200-F125	300	350	1¼"	470	1921	1200	2000	450	1400	200	295
EN BG P1M 125-250-RB IS+J3A	150	DN200-F125	300	350	1¼"	555	2006	1400	2000	550	1400	200	295
EN BG P1M 125-250-RAB IS+J3A	150	DN200-F125	350	350	1¼"	575	2026	1400	2300	550	1400	200	295
EN BG P1M 125-250-250 IC+V12	150	DN200-F125	300	350	1½"	555	2006	1400	2000	550	1400	200	181
EN BG P1M 125-250-264 IC+V12	150	DN200-F125	300	350	1½"	555	2006	1400	2000	550	1400	200	181
EN BG P1M 125-315-RBC287 IS+V12	150	DN200-F125	300	350	1½"	585	2036	1400	2000	550	1400	200	181
EN BG P1M 125-315-RCD295 IS+V18	150	DN200-F125	300	350	1½"	595	2046	1400	2300	550	1400	200	181
EN BG P1M 125-250-278 IC+V18	150	DN200-F125	350	400	1½"	575	2026	1400	2300	550	1400	200	181
EN BG P1M 125-315-RBC302 IS+V18	150	DN200-F125	300	350	1½"	595	2046	1400	2300	550	1400	200	181
EN BG P1M 150-315-RC257 IS+V12	200	DN250-F200	400	400	1½"	595	2252	1400	2300	550	1400	200	181
EN BG P1M 150-315-RC266 IS+V12	200	DN250-F200	400	400	1½"	595	2252	1400	2300	550	1400	200	181
EN BG P1M 150-315-RCD280 IS+V12	200	DN250-F200	300	350	1½"	595	2252	1400	2300	550	1400	200	181
EN BG P1M 150-315-RC290 IS+V18	200	DN250-F200	400	450	1½"	635	2292	1400	2300	550	1400	200	181
EN BG P1M 150-315-RBC284 IS+V18	200	DN250-F200	400	450	1½"	595	2252	1400	2300	550	1400	200	181
EN BG P1M 150-315-RBC290 IS+V18	200	DN250-F200	400	450	1½"	635	2292	1400	2300	550	1400	200	181
EN BG P1M 150-315-RAB310 IS+V18	200	DN250-F200	400	450	1½"	635	2292	1400	2300	550	1400	200	181
EN BG P1M 150-315-RAB315 IS+V18	200	DN250-F200	400	450	1½"	635	2292	1400	2300	550	1400	200	181

IDROFIRE BG PEM

N.1 ELETTOPOMPA DI SERVIZIO + N.1 MOTOPOMPA DI RISERVA + PILOTA
 NR.1 MAIN ELECTRIC PUMP + NR.1 BACKUP DIESEL MOTOR PUMP + JOCKEY PUMP

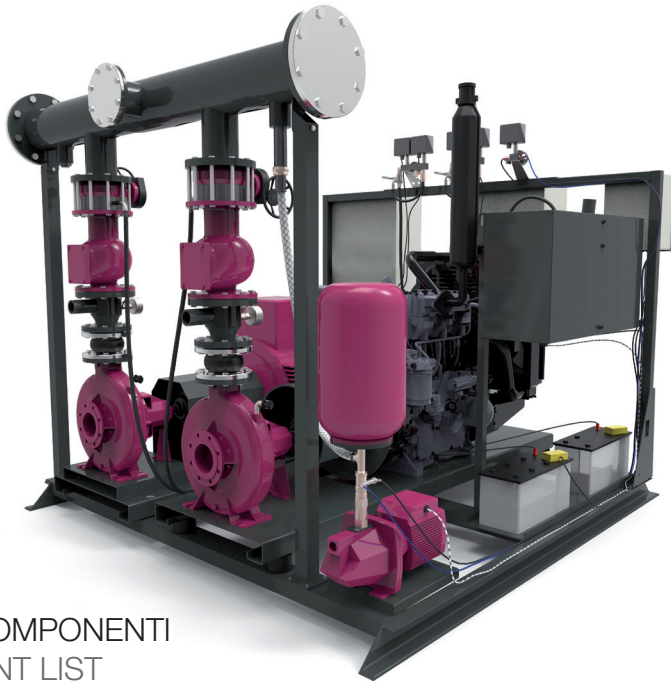

ELENCO COMPONENTI COMPONENT LIST

- | | |
|--|---|
| <ol style="list-style-type: none"> 1. Elettropompa di servizio accoppiata mediante giunto spaziatore completo di protezione coprigiunto 2. Motopompa Diesel di riserva accoppiata mediante giunto spaziatore completo di protezione coprigiunto 3. Elettropompa pilota 4. Valvola di ritegno a clapet 5. Valvola di intercettazione lucchettabile 6. Valvola di ritegno 7. Valvola di intercettazione a sfera con leva 8. Collettore di mandata reversibile completo di flangia cieca 9. Derivazione per collettore di prova di portata 10. Predisposizione per kit sprinkler 11. Kit avviamento per pompe principali composto da 2 pressostati 2-14 bar con pulsante di prova integrato, 1 manometro 0-16 bar e circuito by-pass 12. Kit avviamento per pompa pilota composto da 1 presostato con pulsante di prova integrato, 1 manometro 13. Quadri elettrici di comando (uno per ogni pompa) 14. Mano-vuotometro con porta-manometro e rubinetto provvisto di flangia per controllo 15. Kit diaframma di ricircolo completo di indicatore visivo di flusso 16. Manometro 0-16 bar 17. Serbatoio Autoclave 24 lt PN16 18. Giunti antivibranti in gomma 19. Giunto di compensazione in gomma 20. Serbatoio gasolio per motore Diesel 21. Telaio | <ol style="list-style-type: none"> 1. Main electric pump coupled with coupling joint between motor and pump with spacing protected by carter butt strap 2. Backup Diesel engine pump coupled with coupling joint between motor and pump with spacing protected by carter butt strap 3. Jockey electric pump 4. Swing Check Valve ("Clapet" Valve) 5. Shut-off valve lockable 6. Check valve 7. Ball valve with level 8. Reversible delivery manifold with blind flange 9. Shunt for flow meter 10. Predisposition for sprinkler kit 11. Starting kit for main pump composed by 2 pressure switch 2-14 bar with integrated test button, 1 pressure gauge 0-16 bar and by-pass circuit 12. Starting kit for jockey electric pump composed by 1 pressure switch with integrated test button, 1 pressure gauge 13. Electrical control panels (one for each pump) 14. Vacuum gauge with gauge holder and cock fitted with flange for control 15. Kit recycling diaphragm complete with visual flow indicator 16. Pressure gauge 0-16 bar 17. Diaphragm pressure vessel 24LT PN16 18. Rubber anti-vibration joints 19. Rubber strain neutralizer 20. Fuel tank for diesel engine 21. Frame |
|--|---|

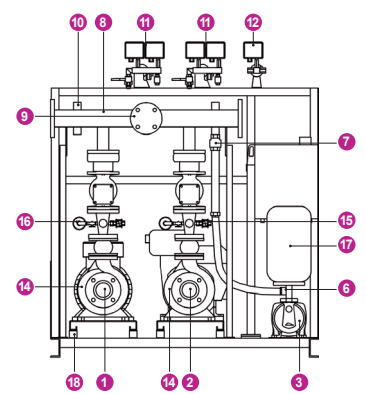
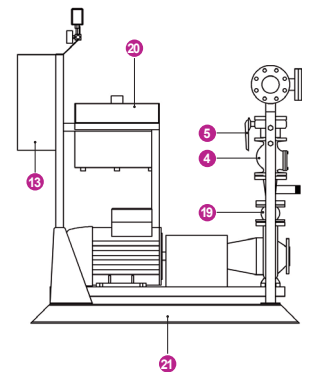

IDROFIRE BG PEM

DATI TECNICI TECHNICAL DATA

MODELLO GRUPPO	MOTORE ELETRICO		MOTORE DIESEL			ELETTROPOMPA PILOTA		KIT FLUSSIMETRO	KIT SOTTOBATTENTE		KIT SOPRABATTENTE
	ELECTRIC ENGINE		DIESEL ENGINE			JOCKEY PUMP		FLOW METER KIT	pompa principale	pompa pilota	pompa principale
MODEL GROUP									POSITIVE HEAD KIT		SUCTION LIFT KIT
									main pump	jockey pump	main pump
BG PEM	mod.	kW	mod.	kW NA	kW NB	mod.	kW	mod.	mod.	DN	mod.
EN BG PEM 32-200-NC ELS+J15	112MA	4	15LD350	4,2	4,6	J15	1,1	CM50-V50	P50-S65	1"	50x80
EN BG PEM 32-200-NB ELS+J15	132SA	5,5	15LD440	6,2	6,7	J15	1,1	CM50-V50	P50-S65	1"	50x80
EN BG PEM 32-200-NA ELS+J15	132SB	7,5	15LD500	7,1	7,8	J15	1,1	CM50-V50	P50-S80	1"	50x80
EN BG PEM 32-250-E ELS+J3A	160MA	11	12LD477/2	13,6	15	J3A	2,2	CM50-V50	P50-S80	1¼"	50x100
EN BG PEM 32-250-225 ELC+J15	160MB	15	12LD477/2	13,6	15	J15	1,1	CM50-V50	P50-S80	1"	50x100
EN BG PEM 32-250-235 ELC+J3A	160MB	15	9LD625/2	17,6	18,9	J3A	2,2	CM50-V50	P50-S80	1¼"	50x100
EN BG PEM 32-250-245 ELC+J3A	160L	18,5	9LD625/2	17,6	18,9	J3A	2,2	CM50-V50	P50-S80	1¼"	50x100
EN BG PEM 32-250-B EPS+J3A	180M	22	LPW 3-09	20,1	22,1	J3A	2,2	CM50-V50	P50-S100	1¼"	50x100
EN BG PEM 32-250-255 ELC+J3A	160L	18,5	9LD625/2	17,6	18,9	J3A	2,2	CM50-V50	P50-S80	1¼"	50x100
EN BG PEM 32-250-264 EPC+J3A	160L	18,5	LPW 3-09	20,1	22,1	J3A	2,2	CM50-V50	P50-S80	1¼"	50x100
EN BG PEM 32-250-A ELS+J3A	180M	22	11LD626/3	24	26	J3A	2,2	CM50-V50	P50-S100	1¼"	50x100
EN BG PEM 40-200-185 ELC+J15	132SB	7,5	15LD500	7,1	7,8	J15	1,1	CM50-V50	P65-S80	1"	65x100
EN BG PEM 40-200-195 ELC+J15	132M	9	25LD425	10,4	11,5	J15	1,1	CM50-V50	P65-S80	1"	65x100
EN BG PEM 40-200-205 ELC+J15	160MA	11	25LD425	10,4	11,5	J15	1,1	CM50-V50	P65-S100	1"	65x100
EN BG PEM 40-200-214 ELC+J15	160MA	11	25LD425	10,4	11,5	J15	1,1	CM50-V50	P65-S100	1"	65x100
EN BG PEM 40-200-NA ELS+J3A	160MA	11	12LD477/2	13,6	15	J3A	2,2	CM65-V50	P65-S100	1¼"	65x100
EN BG PEM 40-250-225 ELC+J15	160MB	15	9LD625/2	17,6	18,9	J15	1,1	CM65-V50	P65-S100	1"	65x125
EN BG PEM 40-250-235 ELC+J3A	160L	18,5	9LD625/2	17,6	18,9	J3A	2,2	CM65-V50	P65-S100	1¼"	65x125
EN BG PEM 40-250-245 EPC+J3A	180M	22	LPW 3-09	20,1	22,1	J3A	2,2	CM65-V50	P65-S100	1¼"	65x125
EN BG PEM 40-250-255 EPC+J3A	180M	22	LPW 3-09	20,1	22,1	J3A	2,2	CM65-V50	P65-S100	1¼"	65x125
EN BG PEM 40-250-264 ELC+J3A	180M	22	11LD626/3	24	26	J3A	2,2	CM65-V50	P65-S100	1¼"	65x125
EN BG PEM 40-250-264 EPC+J3A	180M	22	LPW 4-09	26,8	29,5	J3A	2,2	CM65-V50	P65-S100	1¼"	65x125
EN BG PEM 40-315-RB300 EVS+V18	225M	45	D703LTE0	48	53	V18	2,2	CM65 - V50	P65-S100	1½"	65x125
EN BG PEM 40-315-RAB308 EVS+V18	225M	45	D703LTE0	48	53	V18	2,2	CM65 - V50	P65-S100	1½"	65x125
EN BG PEM 40-315-RAB315 EVS+V18	250M	55	D703LTE0	48	53	V18	2,2	CM65 - V50	P65-S100	1½"	65x125
EN BG PEM 50-160-174 ELC+J15	160MB	15	12LD477/2	13,6	15	J15	1,1	CM65 - V50	P65-S150	1"	65x150
EN BG PEM 50-200-185 ELC+J15	160MA	11	25LD425	10,4	11,5	J15	1,1	CM65-V50	P65-S125	1"	65x125
EN BG PEM 50-200-195 ELC+J15	160MB	15	12LD477/2	13,6	15	J15	1,1	CM65-V50	P65-S125	1"	65x125
EN BG PEM 50-200-C ELS+J15	160MA	11	25LD425	10,4	11,5	J15	1,1	CM65 - V50	P65-S125	1"	65x125
EN BG PEM 50-200-B ELS+J15	160MA	11	12LD477/2	13,6	15	J15	1,1	CM65 - V50	P65-S100	1"	65x125
EN BG PEM 50-200-205 ELC+J15	160MB	15	9LD625/2	17,6	18,9	J15	1,1	CM65-V50	P65-S125	1"	65x125
EN BG PEM 50-200-A ELS+J3A	160MB	15	12LD477/2	13,6	15	J3A	2,2	CM65-V50	P65-S125	1¼"	65x125
EN BG PEM 50-200-214 ELC+J15	160L	18,5	9LD625/2	17,6	18,9	J15	1,1	CM65 - V50	P65-S125	1"	65x125
EN BG PEM 50-200-NB EPS+J15	160L	18,5	LPW 3-09	20,1	22,1	J15	1,1	CM65 - V50	P65-S125	1"	65x150
EN BG PEM 50-200-NA ELS+J3A	180M	22	11LD626/3	24	26	J3A	2,2	CM65 - V50	P65-S150	1¼"	65x150
EN BG PEM 50-200-NA EPS+J3A	180M	22	LPW 4-09	26,8	29,5	J3A	2,2	CM65 - V50	P65-S150	1¼"	65x150
EN BG PEM 50-250-225 EPC+J3A	160L	18,5	LPW 3-09	20,1	22,1	J3A	2,2	CM65-V50	P65-S125	1¼"	65x125
EN BG PEM 50-250-235 ELC+J3A	180M	22	11LD626/3	24	26	J3A	2,2	CM65-V50	P65-S125	1¼"	65x125
EN BG PEM 50-250-235 EPC+J3A	180M	22	LPW 4-09	26,8	29,5	J3A	2,2	CM65-V50	P65-S125	1¼"	65x125
EN BG PEM 50-250-245 ELC+J3A	200LA	30	11LD626/3	24	26	J3A	2,2	CM65 - V50	P65-S125	1¼"	65x125
EN BG PEM 50-250-245 EPC+J3A	200LA	30	LPW 4-09	26,8	29,5	J3A	2,2	CM65 - V50	P65-S125	1¼"	65x125
EN BG PEM 50-250-255 EVC+J3A	200LA	30	D703LE0	33	37	J3A	2,2	CM65 - V50	P65-S125	1¼"	65x125
EN BG PEM 50-250-264 EVC+J3A	200LA	30	D703LE0	33	37	J3A	2,2	CM65 - V50	P65-S125	1¼"	65x125
EN BG PEM 50-250-264 EPC+J3A	200LA	30	LPWT 4-09	37,5	40,2	J3A	2,2	CM65 - V50	P65-S125	1¼"	65x125
EN BG PEM 50-250-NA EVS+J3A	200LB	37	D703LE0	33	37	J3A	2,2	CM65 - V50	P65-S150	1¼"	65x150
EN BG PEM 50-250-NA EPS+J3A	200LB	37	LPWT 4-09	37,5	40,2	J3A	2,2	CM65 - V50	P65-S150	1¼"	65x150
EN BG PEM 50-315-274 EVC+V12	225M	45	D703LTE0	48	53	V12	1,5	CM65-V50	P80-S125	1½"	80x125
EN BG PEM 50-315-291 EVC+V18	250M	55	D703LTE0	48	53	V18	2,2	CM65-V50	P80-S125	1½"	80x125
EN BG PEM 50-315-308 EVC+V18	280S	75	D754TPE2	65	73	V18	2,2	CM65-V50	P80-S125	1½"	80x125
EN BG PEM 65-200-185 EPC+J15	180M	22	LPW 3-09	20,1	22,1	J15	1,1	CM100-V80	P80-S200	1"	80x200
EN BG PEM 65-200-NA EVS+J3A	200LA	30	D703LE0	33	37	J3A	2,2	CM100-V80	P80-S200	1¼"	80x200
EN BG PEM 65-200-195 ELC+J15	200LA	30	11LD626/3	24	26	J15	1,1	CM100-V80	P80-S200	1"	80x200
EN BG PEM 65-200-195 EPC+J15	200LA	30	LPW 4-09	26,8	29,5	J15	1,1	CM100-V80	P80-S200	1"	80x200
EN BG PEM 65-200-205 EPC+J15	200LA	30	LPW 4-09	26,8	29,5	J15	1,1	CM100-V80	P80-S200	1"	80x200
EN BG PEM 65-200-214 EVC+J3A	200LB	37	D703LE0	33	37	J3A	2,2	CM100-V100	P80-S200	1¼"	80x200
EN BG PEM 65-200-214 EPC+J3A	200LB	37	LPWT 4-09	37,5	40,2	J3A	2,2	CM100-V100	P80-S200	1¼"	80x200
EN BG PEM 65-250-225 EVC+J3A	200LB	37	D703LE0	33	37	J3A	2,2	CM100-V80	P80-S200	1¼"	80x200
EN BG PEM 65-250-225 EPC+J3A	200LB	37	LPWT 4-09	37,5	40,2	J3A	2,2	CM100-V80	P80-S200	1¼"	80x200

IDROFIRE BG PEM

DATI TECNICI TECHNICAL DATA

MODELLO GRUPPO	MOTORE ELETRICO		MOTORE DIESEL			ELETTROPOMPA PILOTA		KIT FLUSSIMETRO	KIT SOTTOBATTENTE		KIT SOPRABATTENTE
	ELECTRIC ENGINE		DIESEL ENGINE			JOCKEY PUMP		FLOW METER KIT	pompa principale	pompa pilota	pompa principale
MODEL GROUP									main pump	jockey pump	SUCTION LIFT KIT
BG PEM	mod.	kW	mod.	kW NA	kW NB	mod.	kW	mod.	mod.	DN	mod.
EN BG PEM 65-250-NB EVS+J3A	200LB	37	D703LE0	33	37	J3A	2,2	CM80-V80	P80-S150	1¼"	80x150
EN BG PEM 65-250-NB EPS+J3A	200LB	37	LPWT 4-09	37,5	40,2	J3A	2,2	CM80-V80	P80-S150	1¼"	80x150
EN BG PEM 65-250-235 EVC+J3A	200LB	37	D703LTE0	48	53	J3A	2,2	CM100-V80	P80-S200	1¼"	80x200
EN BG PEM 65-250-235 EPC+J3A	200LB	37	LPWT 4-09	37,5	40,2	J3A	2,2	CM100-V80	P80-S200	1¼"	80x200
EN BG PEM 65-250-245 EVC+J3A	225M	45	D703LTE0	48	53	J3A	2,2	CM100-V80	P80-S200	1¼"	80x200
EN BG PEM 65-250-255 EVC+J3A	250M	55	D703LTE0	48	53	J3A	2,2	CM100-V80	P80-S200	1¼"	80x200
EN BG PEM 65-250-NOA EVS+J3A	225M	45	D703LTE0	48	53	J3A	2,2	CM100-V80	P80-S200	1¼"	80x200
EN BG PEM 65-250-264 EVC+J3A	250M	55	D754TPE2	65	73	J3A	2,2	CM100-V80	P80-S200	1¼"	80x200
EN BG PEM 65-250-NO EVS+J3A	250M	55	D703LTE0	48	53	J3A	2,2	CM100-V80	P80-S150	1¼"	80x200
EN BG PEM 65-315-RCD273 EVS+V12	250M	55	D754TPE2	65	73	V12	1,5	CM100-V80	P80-S200	1½"	80x200
EN BG PEM 65-315-RBC282 EVS+V18	280S	75	D754TPE2	65	73	V18	2,2	CM100-V80	P80-S200	1½"	80x200
EN BG PEM 65-315-291 EVC+V18	280M	90	D756IPE2	100	110	V18	2,2	CM100-V80	P80-S200	1½"	80x200
EN BG PEM 65-315-308 EIC+V18	315S	110	N45 MNT F41	130,5	145	V18	2,2	CM100-V80	P80-S200	1½"	80x200
EN BG PEM 80-200-195 EVC+J15	200LA	30	D703LE0	33	37	J15	1,1	CM125-V100	P100-S250	1"	100x250
EN BG PEM 80-200-195 EPC+J15	200LA	30	LPWT 4-09	37,5	40,2	J15	1,1	CM125-V100	P100-S250	1"	100x250
EN BG PEM 80-200-205 EVC+J15	200LB	37	D703LTE0	48	53	J15	1,1	CM125-V100	P100-S250	1"	100x250
EN BG PEM 80-200-205 EPC+J15	200LB	37	LPWT 4-09	37,5	40,2	J15	1,1	CM125-V100	P100-S250	1"	100x250
EN BG PEM 80-200-214 EVC+J3A	225M	45	D703LTE0	48	53	J3A	2,2	CM125-V125	P100-S250	1¼"	100x250
EN BG PEM 80-250-225 EVC+J3A	225M	45	D703LTE0	48	53	J3A	2,2	CM100-V100	P100-S200	1¼"	100x250
EN BG PEM 80-250-235 EVC+J3A	250M	55	D703LTE0	48	53	J3A	2,2	CM125-V100	P100-S200	1¼"	100x250
EN BG PEM 80-250-245 EVC+J3A	250M	55	D754TPE2	65	73	J3A	2,2	CM125-V100	P100-S250	1¼"	100x250
EN BG PEM 80-250-255 EVC+J3A	280S	75	D754TPE2	65	73	J3A	2,2	CM125-V100	P100-S250	1¼"	100x250
EN BG PEM 80-250-264 EVC+J3A	280S	75	D756IPE2	100	110	J3A	2,2	CM125-V125	P100-S250	1¼"	100x250
EN BG PEM 80-250-A EVS+J3A	315S	110	D756IPE2	100	110	J3A	2,2	CM125-V100	P100-S200	1¼"	100x250
EN BG PEM 100-200-195 EVC+J15	200LB	37	D703LTE0	48	53	J15	1,1	CM125-V125	P125-S250	1"	125x300
EN BG PEM 100-200-195 EPC+J15	200LB	37	LPWT 4-09	37,5	40,2	J15	1,1	CM125-V125	P125-S250	1"	125x300
EN BG PEM 100-200-205 EVC+J15	250M	55	D703LTE0	48	53	J15	1,1	CM125-V125	P125-S250	1"	125x300
EN BG PEM 100-200-214 EVC+J3A	250M	55	D754TPE2	65	73	J3A	2,2	CM125-V125	P125-S250	1¼"	125x300
EN BG PEM 100-250-225 EVC+J3A	280S	75	D754TPE2	65	73	J3A	2,2	CM125-V125	P125-S300	1¼"	125x300
EN BG PEM 100-250-235 EVC+J3A	280S	75	D756IPE2	100	110	J3A	2,2	CM125-V125	P125-S300	1¼"	125x300
EN BG PEM 100-250-245 EVC+J3A	280M	90	D756IPE2	100	110	J3A	2,2	CM125-V125	P125-S300	1¼"	125x300
EN BG PEM 100-250-255 EIC+J3A	315S	110	N45 MNT F41	130,5	145	J3A	2,2	CM125-V125	P125-S300	1¼"	125x350
EN BG PEM 100-250-264 EIC+J3A	315MA	132	N45 MNT F41	130,5	145	J3A	2,2	CM125-V125	P125-S300	1¼"	125x350
EN BG PEM 100-315-291 EIC+V18	315S	110	N45 MNT F41	130,5	145	V18	2,2	CM125-V125	P150-S250	1½"	150x250
EN BG PEM 100-315-RBC292 EIS+V18	315MA	132	N45 MNT F41	130,5	145	V18	2,2	CM125-V125	P125-S300	1½"	125x300
EN BG PEM 100-315-RBC296 EIS+V18	315MB	160	N67 MNT F42	178	197	V18	2,2	CM125-V125	P125-S300	1½"	125x300
EN BG PEM 100-315-RBC308 EIS+V18	315MB	160	N67 MNT F42	178	197	V18	2,2	CM125-V125	P125-S300	1½"	125x300
EN BG PEM 100-315-308 EIC+V18	315MA	132	N45 MNT F41	130,5	145	V18	2,2	CM125-V125	P150-S300	1½"	150x300
EN BG PEM 125-200-205 EVC+J15	280S	75	D754TPE2	65	73	J15	1,1	CM200-V200	P150-S300	1"	150x350
EN BG PEM 125-200-214 EVC+J15	280S	75	D756IPE2	100	110	J15	1,1	CM200-V200	P150-S350	1"	150x350
EN BG PEM 125-250-RC EVS+J3A	280M	90	D756IPE2	100	110	J3A	2,2	CM125-V125	P125-S300	1¼"	150x350
EN BG PEM 125-250-RB EIS+J3A	315MA	132	N45 MNT F41	130,5	145	J3A	2,2	CM150-V125	P150-S300	1¼"	150x350
EN BG PEM 125-250-RAB EIS+J3A	315MB	160	N67 MNT F42	178	197	J3A	2,2	CM150-V125	P150-S350	1¼"	150x350
EN BG PEM 125-250-250 EIC+V12	315MA	132	N45 MNT F41	130,5	145	V12	1,1	CM200-V200	P150-S300	1½"	150x350
EN BG PEM 125-250-264 EIC+V12	315MA	132	N45 MNT F41	130,5	145	V12	1,1	CM200-V200	P150-S300	1½"	150x350
EN BG PEM 125-315-RBC287 EIS+V12	315MB	160	N67 MNT F42	178	197	V12	1,5	CM125-V125	P150-S300	1½"	150x350
EN BG PEM 125-315-RCD295 EIS+V18	315MB	160	N67 MNT F42	178	197	V18	2,2	CM125-V125	P150-S300	1½"	150x350
EN BG PEM 125-250-278 EIC+V18	315L	200	N67 MNT F42	178	197	V18	2,2	CM200-V200	P150-S350	1½"	150x400
EN BG PEM 125-315-RBC302 EIS+V18	315L	200	N67 MNT F42	178	197	V18	2,2	CM125-V125	P150-S300	1½"	150x350
EN BG PEM 150-315-RC257 EIS+V12	315MB	160	N67 MNT F42	178	197	V12	1,5	CM200-V200	P200-S400	1½"	200x400
EN BG PEM 150-315-RC266 EIS+V12	315MB	160	N67 MNT F42	178	197	V12	1,5	CM200-V200	P200-S400	1½"	200x400
EN BG PEM 150-315-RCD280 EIS+V12	315L	200	N67 MNT F42	200	222	V12	1,5	CM200-V200	P200-S300	1½"	200x350
EN BG PEM 150-315-RC290 EIS+V18	355MB	250	N67 MNT F40	227	246	V18	2,2	CM200-V200	P200-S400	1½"	200x450
EN BG PEM 150-315-RBC284 EIS+V18	315L	200	N67 MNT F42	200	222	V18	2,2	CM200-V200	P200-S400	1½"	200x450
EN BG PEM 150-315-RBC290 EIS+V18	355MB	250	N67 MNT F40	227	246	V18	2,2	CM200-V200	P200-S400	1½"	200x450
EN BG PEM 150-315-RAB310 EIS+V18	355LB	315	N60 ENT F 40	282	295	V18	2,2	CM200-V200	P200-S400	1½"	200x450
EN BG PEM 150-315-RAB315 EIS+V18	355LB	315	N60 ENT F 40	282	295	V18	2,2	CM200-V200	P200-S400	1½"	200x450

IDROFIRE BG PEM

DIMENSIONI DIMENSION

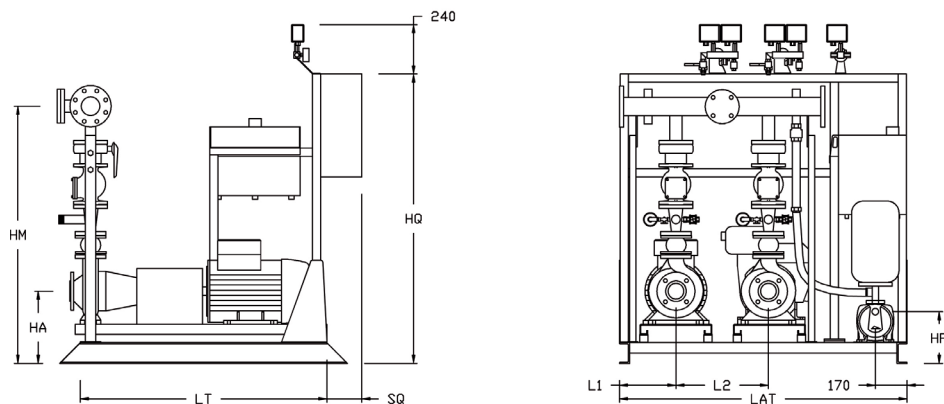

MODELLO GRUPPO	MANDATA		ASPIRAZIONE		PILOTA	HA	HM	LAT	LT	L1	L2	HQ	SQ	HP
	KIT VLV	collettore	STB	STB										
	DELIVERY valves kit	manifold	SUCTION posit. head	posit. head										
MODEL GROUP	DN	DN	DN	DN	DN AxM	mm	mm	mm	mm	mm	mm	mm	mm	mm
EN BG PEM 32-200-NC ELS+J15	40	DN80-F50	65	80	1"	370	1243	1400	1100	300	500	1400	200	277
EN BG PEM 32-200-NB ELS+J15	40	DN80-F50	65	80	1"	370	1243	1400	1100	300	500	1400	200	277
EN BG PEM 32-200-NA ELS+J15	40	DN80-F50	80	80	1"	370	1243	1400	1100	300	500	1400	200	277
EN BG PEM 32-250-E ELS+J3A	40	DN80-F50	80	100	1 1/4"	390	1308	1400	1100	300	500	1400	200	295
EN BG PEM 32-250-225 ELC+J15	40	DN80-F50	80	100	1"	390	1308	1400	1100	300	500	1400	200	277
EN BG PEM 32-250-235 ELC+J3A	40	DN80-F50	80	100	1 1/4"	390	1308	1500	1300	350	500	1400	200	295
EN BG PEM 32-250-245 ELC+J3A	40	DN80-F50	80	100	1 1/4"	390	1308	1500	1300	350	500	1400	200	295
EN BG PEM 32-250-B EPS+J3A	50	DN80-F50	100	100	1 1/4"	390	1338	1600	1400	375	550	1400	200	295
EN BG PEM 32-250-255 ELC+J3A	40	DN80-F50	80	100	1 1/4"	390	1308	1500	1300	350	500	1400	200	295
EN BG PEM 32-250-264 EPC+J3A	40	DN80-F50	80	100	1 1/4"	390	1308	1600	1400	375	550	1400	200	295
EN BG PEM 32-250-A ELS+J3A	50	DN80-F50	100	100	1 1/4"	434	1382	1600	1400	375	550	1400	200	295
EN BG PEM 40-200-185 ELC+J15	50	DN80-F50	80	100	1"	370	1273	1400	1100	300	500	1400	200	277
EN BG PEM 40-200-195 ELC+J15	50	DN80-F50	80	100	1"	370	1273	1400	1100	300	500	1400	200	277
EN BG PEM 40-200-205 ELC+J15	50	DN80-F50	100	100	1"	370	1273	1400	1100	300	500	1400	200	277
EN BG PEM 40-200-214 ELC+J15	50	DN80-F50	100	100	1"	370	1273	1400	1100	300	500	1400	200	277
EN BG PEM 40-200-NA ELS+J3A	50	DN80-F50	100	100	1 1/4"	395	1298	1400	1100	300	500	1400	200	295
EN BG PEM 40-250-225 ELC+J15	50	DN80-F50	100	125	1"	390	1338	1500	1300	350	500	1400	200	277
EN BG PEM 40-250-235 ELC+J3A	50	DN80-F50	100	125	1 1/4"	390	1338	1500	1300	350	500	1400	200	295
EN BG PEM 40-250-245 EPC+J3A	50	DN80-F50	100	125	1 1/4"	390	1338	1600	1400	375	550	1400	200	295
EN BG PEM 40-250-255 EPC+J3A	50	DN80-F50	100	125	1 1/4"	390	1338	1600	1400	375	550	1400	200	295
EN BG PEM 40-250-264 ELC+J3A	50	DN80-F50	100	125	1 1/4"	434	1382	1600	1400	375	550	1400	200	295
EN BG PEM 40-250-264 EPC+J3A	50	DN80-F50	100	125	1 1/4"	400	1348	1600	1600	375	550	1400	200	295
EN BG PEM 40-315-RB300 EVS+V18	65	DN80-F50	100	125	1 1/2"	445	1461	1900	1600	450	700	1400	200	181
EN BG PEM 40-315-RAB308 EVS+V18	65	DN80-F50	100	125	1 1/2"	445	1461	1900	1600	450	700	1400	200	181
EN BG PEM 40-315-RAB315 EVS+V18	65	DN80-F50	100	125	1 1/2"	445	1461	1900	1800	450	700	1400	200	181
EN BG PEM 50-160-174 ELC+J15	65	DN80-F50	150	150	1"	395	1351	1400	1100	300	500	1400	200	277
EN BG PEM 50-200-185 ELC+J15	65	DN80-F50	125	125	1"	370	1346	1400	1100	300	500	1400	200	277
EN BG PEM 50-200-195 ELC+J15	65	DN80-F50	125	125	1"	395	1371	1400	1100	300	500	1400	200	277
EN BG PEM 50-200-C ELS+J15	65	DN80-F50	125	125	1"	370	1346	1400	1100	300	500	1400	200	277
EN BG PEM 50-200-B ELS+J15	65	DN80-F50	100	125	1"	395	1371	1400	1100	300	500	1400	200	277
EN BG PEM 50-200-205 ELC+J15	65	DN80-F50	125	125	1"	388	1364	1500	1300	350	500	1400	200	277
EN BG PEM 50-200-A ELS+J3A	65	DN80-F50	125	125	1 1/4"	395	1371	1400	1100	300	500	1400	200	295
EN BG PEM 50-200-214 ELC+J15	65	DN80-F50	125	125	1"	388	1364	1500	1300	350	500	1400	200	277
EN BG PEM 50-200-NB EPS+J15	65	DN80-F50	125	150	1"	380	1356	1600	1400	375	550	1400	200	277
EN BG PEM 50-200-NA ELS+J3A	65	DN80-F50	150	150	1 1/4"	434	1410	1600	1400	375	550	1400	200	295
EN BG PEM 50-200-NA EPS+J3A	65	DN80-F50	150	150	1 1/4"	390	1366	1600	1600	375	550	1400	200	295
EN BG PEM 50-250-225 EPC+J3A	65	DN80-F50	125	125	1 1/4"	390	1391	1600	1400	375	550	1400	200	295
EN BG PEM 50-250-235 ELC+J3A	65	DN80-F50	125	125	1 1/4"	434	1435	1600	1400	375	550	1400	200	295
EN BG PEM 50-250-235 EPC+J3A	65	DN80-F50	125	125	1 1/4"	400	1401	1600	1600	375	550	1400	200	295

IDROFIRE BG PEM

DIMENSIONI DIMENSION

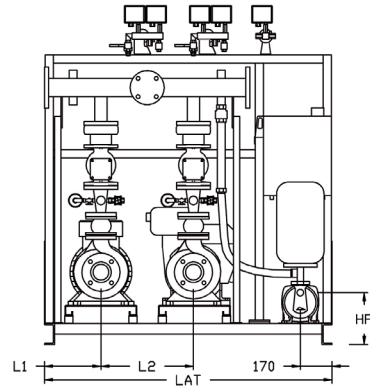
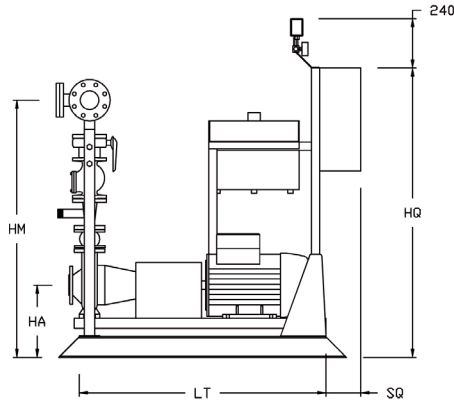

MODELLO GRUPPO	MANDATA		ASPIRAZIONE		PILOTA	HA	HM	LAT	LT	L1	L2	HQ	SQ	HP
	KIT VLV	collettore	STB	STB										
	DELIVERY valves kit	manifold	SUCTION posit. head	posit. head										
BG PEM	DN	DN	DN	DN	DN AxM	mm	mm	mm	mm	mm	mm	mm	mm	mm
EN BG PEM 50-250-245 ELC+J3A	65	DN80-F50	125	125	1¼"	434	1435	1600	1400	375	550	1400	200	295
EN BG PEM 50-250-245 EPC+J3A	65	DN80-F50	125	125	1¼"	400	1401	1600	1600	375	550	1400	200	295
EN BG PEM 50-250-255 EVC+J3A	65	DN80-F50	125	125	1¼"	400	1401	1900	1600	450	700	1400	200	295
EN BG PEM 50-250-264 EVC+J3A	65	DN80-F50	125	125	1¼"	400	1401	1900	1600	450	700	1400	200	295
EN BG PEM 50-250-264 EPC+J3A	65	DN80-F50	125	125	1¼"	400	1401	1600	1600	375	550	1400	200	295
EN BG PEM 50-250-NA EVS+J3A	65	DN80-F50	150	150	1¼"	400	1401	1900	1600	450	700	1400	200	295
EN BG PEM 50-250-NA EPS+J3A	65	DN80-F50	150	150	1¼"	400	1401	1600	1600	375	550	1400	200	295
EN BG PEM 50-315-274 EVC+V12	65	DN80-F50	125	125	1½"	445	1501	1900	1600	450	700	1400	200	181
EN BG PEM 50-315-291 EVC+V18	65	DN80-F50	125	125	1½"	445	1501	1900	1800	450	700	1400	200	181
EN BG PEM 50-315-308 EVC+V18	65	DN80-F50	125	125	1½"	450	1506	1900	1800	450	700	1400	300	181
EN BG PEM 65-200-185 EPC+J15	100	DN125-F80	200	200	1"	390	1512	1600	1400	375	550	1400	200	277
EN BG PEM 65-200-NA EVS+J3A	100	DN125-F80	200	200	1¼"	400	1522	1900	1600	450	700	1400	200	295
EN BG PEM 65-200-195 EVC+J15	100	DN125-F80	200	200	1"	434	1556	1600	1400	375	550	1400	200	277
EN BG PEM 65-200-195 EPC+J15	100	DN125-F80	200	200	1"	400	1522	1600	1600	375	550	1400	200	277
EN BG PEM 65-200-205 EPC+J15	100	DN125-F80	200	200	1"	400	1522	1600	1600	375	550	1400	200	277
EN BG PEM 65-200-214 EVC+J3A	100	DN125-F80	200	200	1¼"	400	1522	1900	1600	450	700	1400	200	295
EN BG PEM 65-200-214 EPC+J3A	100	DN125-F80	200	200	1¼"	400	1522	1600	1600	375	550	1400	200	295
EN BG PEM 65-250-225 EVC+J3A	100	DN125-F80	200	200	1¼"	420	1567	1900	1600	450	700	1400	200	295
EN BG PEM 65-250-225 EPC+J3A	100	DN125-F80	200	200	1¼"	420	1567	1600	1600	375	550	1400	200	295
EN BG PEM 65-250-NB EVS+J3A	80	DN100-F80	150	150	1¼"	420	1488	1900	1600	450	700	1400	200	295
EN BG PEM 65-250-NB EPS+J3A	80	DN100-F80	150	150	1¼"	420	1488	1600	1600	375	550	1400	200	295
EN BG PEM 65-250-235 EVC+J3A	100	DN125-F80	200	200	1¼"	420	1567	1900	1600	450	700	1400	200	295
EN BG PEM 65-250-235 EPC+J3A	100	DN125-F80	200	200	1¼"	420	1567	1600	1600	375	550	1400	200	295
EN BG PEM 65-250-245 EVC+J3A	100	DN125-F80	200	200	1¼"	420	1567	1900	1600	450	700	1400	200	295
EN BG PEM 65-250-255 EVC+J3A	100	DN125-F80	200	200	1¼"	420	1567	1900	1800	450	700	1400	200	295
EN BG PEM 65-250-NOA EVS+J3A	100	DN125-F80	200	200	1¼"	420	1567	1900	1600	450	700	1400	200	295
EN BG PEM 65-250-264 EVC+J3A	100	DN125-F80	200	200	1¼"	420	1567	1900	1800	450	700	1400	200	295
EN BG PEM 65-250-N0 EVS+J3A	100	DN125-F80	150	200	1¼"	420	1567	1900	1800	450	700	1400	200	295
EN BG PEM 65-315-RCD273 EVS+V12	100	DN125-F80	200	200	1½"	445	1622	1900	1800	450	700	1400	200	181
EN BG PEM 65-315-RBC282 EVS+V18	100	DN125-F80	200	200	1½"	450	1627	1900	1800	450	700	1400	300	181
EN BG PEM 65-315-291 EVC+V18	100	DN125-F80	200	200	1½"	450	1627	2000	2000	475	750	1400	300	181
EN BG PEM 65-315-308 EIC+V18	100	DN125-F80	200	200	1½"	555	1732	2200	2300	525	850	1400	300	181
EN BG PEM 80-200-195 EVC+J15	125	DN150-F100	250	250	1"	400	1630	1900	1600	450	700	1400	200	277
EN BG PEM 80-200-195 EPC+J15	125	DN150-F100	250	250	1"	400	1630	1600	1600	375	550	1400	200	277
EN BG PEM 80-200-205 EVC+J15	125	DN150-F100	250	250	1"	400	1630	1900	1600	450	700	1400	200	277
EN BG PEM 80-200-205 EPC+J15	125	DN150-F100	250	250	1"	400	1630	1600	1600	375	550	1400	200	277
EN BG PEM 80-200-214 EVC+J3A	125	DN150-F100	250	250	1¼"	400	1630	1900	1600	450	700	1400	200	295
EN BG PEM 80-250-225 EVC+J3A	125	DN150-F100	200	250	1¼"	420	1680	1900	1600	450	700	1400	200	295
EN BG PEM 80-250-235 EVC+J3A	125	DN150-F100	200	250	1¼"	420	1680	1900	1800	450	700	1400	200	295

IDROFIRE BG PEM

DIMENSIONI DIMENSION

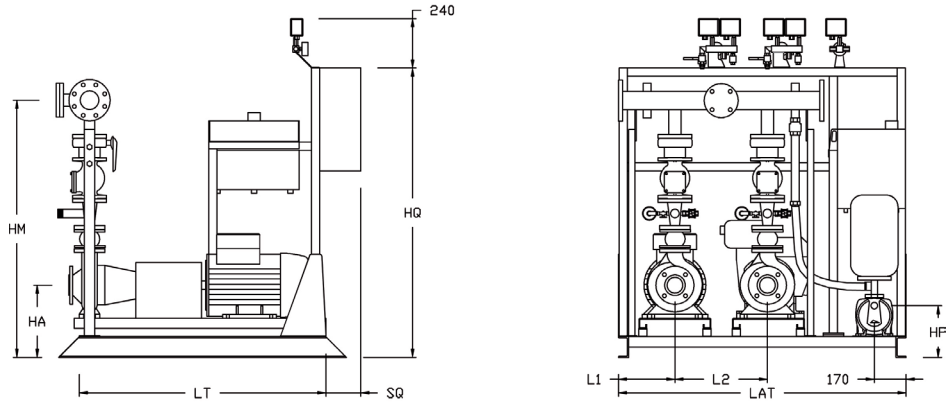

MODELLO GRUPPO	MANDATA		ASPIRAZIONE		PILOTA	HA	HM	LAT	LT	L1	L2	HQ	SQ	HP
	KIT VLV	collettore	STB	STB										
MODEL GROUP	DELIVERY	manifold	SUCTION	posit. head	JOCKEY PUMP	HA	HM	LAT	LT	L1	L2	HQ	SQ	HP
BG PEM	DN	DN	DN	DN	DN AxM	mm	mm	mm	mm	mm	mm	mm	mm	mm
EN BG PEM 80-250-245 EVC+J3A	125	DN150-F100	250	250	1¼"	420	1680	1900	1800	450	700	1400	200	295
EN BG PEM 80-250-255 EVC+J3A	125	DN150-F100	250	250	1¼"	450	1710	1900	1800	450	700	1400	300	295
EN BG PEM 80-250-264 EVC+J3A	125	DN150-F100	250	250	1¼"	450	1710	2000	2000	475	750	1400	300	295
EN BG PEM 80-250-A EVC+J3A	125	DN150-F100	200	250	1¼"	555	1815	2200	2300	525	850	1400	300	295
EN BG PEM 100-200-195 EVC+J15	150	DN200-F125	250	300	1"	420	1761	1900	1600	450	700	1400	200	277
EN BG PEM 100-200-195 EPC+J15	150	DN200-F125	250	300	1"	420	1761	1600	1600	375	550	1400	200	277
EN BG PEM 100-200-205 EVC+J15	150	DN200-F125	250	300	1"	420	1761	1900	1800	450	700	1400	200	277
EN BG PEM 100-200-214 EVC+J3A	150	DN200-F125	250	300	1¼"	420	1761	1900	1800	450	700	1400	200	295
EN BG PEM 100-250-225 EVC+J3A	150	DN200-F125	300	300	1¼"	450	1791	1900	1800	450	700	1400	300	295
EN BG PEM 100-250-235 EVC+J3A	150	DN200-F125	300	300	1¼"	450	1791	2000	2000	475	750	1400	300	295
EN BG PEM 100-250-245 EVC+J3A	150	DN200-F125	300	300	1¼"	450	1791	2000	2000	475	750	1400	300	295
EN BG PEM 100-250-255 EIC+J3A	150	DN200-F125	300	350	1¼"	555	1896	2200	2300	525	850	1400	300	295
EN BG PEM 100-250-264 EIC+J3A	150	DN200-F125	300	350	1¼"	555	1896	2200	2300	525	850	1400	300	295
EN BG PEM 100-315-291 EIC+V18	150	DN200-F125	250	250	1½"	555	1931	2200	2300	525	850	1400	300	181
EN BG PEM 100-315-RBC292 EIS+V18	150	DN200-F125	300	300	1½"	555	1931	2200	2300	525	850	1400	300	181
EN BG PEM 100-315-RBC296 EIS+V18	150	DN200-F125	300	300	1½"	575	1951	2200	2300	525	850	1400	300	181
EN BG PEM 100-315-RBC308 EIS+V18	150	DN200-F125	300	300	1½"	575	1951	2200	2300	525	850	1400	300	181
EN BG PEM 100-315-308 EIC+V18	150	DN200-F125	300	300	1½"	555	1931	2200	2300	525	850	1400	300	181
EN BG PEM 125-200-205 EVC+J15	150	DN200-F125	300	350	1"	470	1881	1900	1800	450	700	1400	300	277
EN BG PEM 125-200-214 EVC+J15	150	DN200-F125	350	350	1"	470	1881	2000	2000	475	750	1400	300	277
EN BG PEM 125-250-RC EVC+J3A	150	DN200-F125	300	350	1¼"	470	1921	2000	2000	475	750	1400	300	295
EN BG PEM 125-250-RB EIS+J3A	150	DN200-F125	300	350	1¼"	555	2006	2200	2300	525	850	1400	300	295
EN BG PEM 125-250-RAB EIS+J3A	150	DN200-F125	350	350	1¼"	575	2026	2200	2300	525	850	1400	300	295
EN BG PEM 125-250-250 EIC+V12	150	DN200-F125	300	350	1½"	555	2006	2200	2300	525	850	1400	300	181
EN BG PEM 125-250-264 EIC+V12	150	DN200-F125	300	350	1½"	555	2006	2200	2300	525	850	1400	300	181
EN BG PEM 125-315-RBC287 EIS+V12	150	DN200-F125	300	350	1½"	585	2036	2200	2300	525	850	1400	300	181
EN BG PEM 125-315-RCD295 EIS+V18	150	DN200-F125	300	350	1½"	595	2046	2200	2300	525	850	1400	300	181
EN BG PEM 125-250-278 EIC+V18	150	DN200-F125	350	400	1½"	575	2026	2200	2300	525	850	1400	300	181
EN BG PEM 125-315-RBC302 EIS+V18	150	DN200-F125	300	350	1½"	595	2046	2200	2300	525	850	1400	370	181
EN BG PEM 150-315-RC257 EIS+V12	200	DN250-F200	400	400	1½"	595	2252	2200	2300	525	850	1400	300	181
EN BG PEM 150-315-RC266 EIS+V12	200	DN250-F200	400	400	1½"	595	2252	2200	2300	525	850	1400	300	181
EN BG PEM 150-315-RC280 EIS+V12	200	DN250-F200	300	350	1½"	595	2252	2200	2300	525	850	1400	370	181
EN BG PEM 150-315-RC290 EIS+V18	200	DN250-F200	400	450	1½"	635	2292	2500	2500	575	950	1400	370	181
EN BG PEM 150-315-RBC284 EIS+V18	200	DN250-F200	400	450	1½"	595	2252	2200	2300	525	850	1400	370	181
EN BG PEM 150-315-RBC290 EIS+V18	200	DN250-F200	400	450	1½"	635	2292	2500	2500	575	950	1400	370	181
EN BG PEM 150-315-RAB310 EIS+V18	200	DN250-F200	400	450	1½"	635	2292	2500	2500	575	950	1400	370	181
EN BG PEM 150-315-RAB315 EIS+V18	200	DN250-F200	400	450	1½"	635	2292	2500	2500	575	950	1400	370	181

IDROFIRE BG MTP

N.1 MOTOPOMPA DI SERVIZIO (O DI RISERVA)
NR.1 MAIN (OR BACKUP) DIESEL MOTOR PUMP

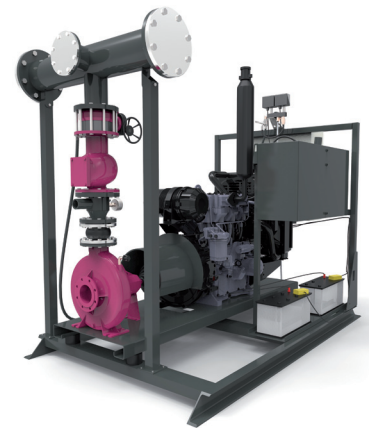

ELENCO COMPONENTI COMPONENT LIST

1. Motopompa Diesel di servizio (o di riserva) accoppiata mediante giunto spaziatore completo di protezione coprigiunto
2. Valvola di ritegno a clapet
3. Valvola di intercettazione lucchettabile
4. Collettore di mandata reversibile completo di flangia cieca
5. Derivazione per collettore di prova di portata
6. Predisposizione per kit sprinkler
7. Kit avviamento per pompe principali composto da 2 pressostati 2-14 bar con pulsante di prova integrato, 1 manometro 0-16 bar e circuito by-pass
8. Quadri elettrici di comando (uno per ogni pompa)
9. Mano-vuotometro con porta-manometro e rubinetto provvisto di flangia per controllo
10. Kit diaframma di ricircolo completo di indicatore visivo di flusso
11. Manometro 0-16 bar
12. Giunti antivibranti in gomma
13. Giunto di compensazione in gomma
14. Serbatoio gasolio per motore Diesel
15. Telaio

1. Main (or backup) Diesel engine pump coupled with coupling joint between motor and pump with spacing protected by carter butt strap
2. Swing Check Valve ("Clapet" Valve)
3. Shut-off valve lockable
4. Reversible delivery manifold with blind flange
5. Shunt for flow meter
6. Predisposition for sprinkler kit
7. Starting kit for main pump composed by 2 pressure switch 2-14 bar with integrated test button, 1 pressure gauge 0-16 bar and by-pass circuit
8. Electrical control panels (one for each pump)
9. Vacuum gauge with gauge holder and cock fitted with flange for control
10. Kit recycling diaphragm complete with visual flow indicator
11. Pressure gauge 0-16 bar
12. Rubber anti-vibration joints
13. Rubber strain neutralizer
14. Fuel tank for diesel engine
15. Frame

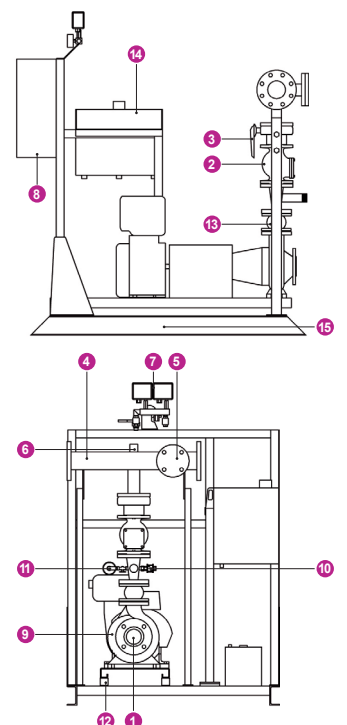

IDROFIRE BG MTP

DATI TECNICI TECHNICAL DATA

MODELLO GRUPPO	MOTORE DIESEL			KIT FLUSSIMETRO	KIT SOTTOBATTENTE	KIT SOPRABATTENTE
	DIESEL ENGINE			FLOW METER KIT	pompa principale POSITIVE HEAD KIT main pump	pompa principale SUCTION LIFT KIT main pump
BG MTP	mod.	kW NA	kW NB	mod.	mod.	mod.
EN BG MTP 32-200-NC LS	15LD350	4,2	4,6	CM50-V50	P50-S65	50x80
EN BG MTP 32-200-NB LS	15LD440	6,2	6,7	CM50-V50	P50-S65	50x80
EN BG MTP 32-200-NA LS	15LD500	7,1	7,8	CM50-V50	P50-S80	50x80
EN BG MTP 32-250-E LS	12LD477/2	13,6	15	CM50-V50	P50-S80	50x100
EN BG MTP 32-250-225 LC	12LD477/2	13,6	15	CM50-V50	P50-S80	50x100
EN BG MTP 32-250-235 LC	9LD625/2	17,6	18,9	CM50-V50	P50-S80	50x100
EN BG MTP 32-250-245 LC	9LD625/2	17,6	18,9	CM50-V50	P50-S80	50x100
EN BG MTP 32-250-B PS	LPW 3-09	20,1	22,1	CM50-V50	P50-S100	50x100
EN BG MTP 32-250-255 LC	9LD625/2	17,6	18,9	CM50-V50	P50-S80	50x100
EN BG MTP 32-250-264 PC	LPW 3-09	20,1	22,1	CM50-V50	P50-S80	50x100
EN BG MTP 32-250-A LS	11LD626/3	24	26	CM50-V50	P50-S100	50x100
EN BG MTP 40-200-185 LC	15LD500	7,1	7,8	CM50-V50	P65-S80	65x100
EN BG MTP 40-200-195 LC	25LD425	10,4	11,5	CM50-V50	P65-S80	65x100
EN BG MTP 40-200-205 LC	25LD425	10,4	11,5	CM50-V50	P65-S100	65x100
EN BG MTP 40-200-214 LC	25LD425	10,4	11,5	CM50-V50	P65-S100	65x100
EN BG MTP 40-200-NA LS	12LD477/2	13,6	15	CM65-V50	P65-S100	65x100
EN BG MTP 40-250-225 LC	9LD625/2	17,6	18,9	CM65-V50	P65-S100	65x125
EN BG MTP 40-250-235 LC	9LD625/2	17,6	18,9	CM65-V50	P65-S100	65x125
EN BG MTP 40-250-245 PC	LPW 3-09	20,1	22,1	CM65-V50	P65-S100	65x125
EN BG MTP 40-250-255 PC	LPW 3-09	20,1	22,1	CM65-V50	P65-S100	65x125
EN BG MTP 40-250-264 LC	11LD626/3	24	26	CM65-V50	P65-S100	65x125
EN BG MTP 40-250-264 PC	LPW 4-09	26,8	29,5	CM65-V50	P65-S100	65x125
EN BG MTP 40-315-RB300 VS	D703LTE0	48	53	CM65 - V50	P65-S100	65x125
EN BG MTP 40-315-RAB308 VS	D703LTE0	48	53	CM65 - V50	P65-S100	65x125
EN BG MTP 40-315-RAB315 VS	D703LTE0	48	53	CM65 - V50	P65-S100	65x125
EN BG MTP 50-160-174 LC	12LD477/2	13,6	15	CM65 - V50	P65-S150	65x150
EN BG MTP 50-200-185 LC	25LD425	10,4	11,5	CM65-V50	P65-S125	65x125
EN BG MTP 50-200-195 LC	12LD477/2	13,6	15	CM65-V50	P65-S125	65x125
EN BG MTP 50-200-C LS	25LD425	10,4	11,5	CM65 - V50	P65-S125	65x125
EN BG MTP 50-200-B LS	12LD477/2	13,6	15	CM65 - V50	P65-S100	65x125
EN BG MTP 50-200-205 LC	9LD625/2	17,6	18,9	CM65-V50	P65-S125	65x125
EN BG MTP 50-200-A LS	12LD477/2	13,6	15	CM65-V50	P65-S125	65x125
EN BG MTP 50-200-214 LC	9LD625/2	17,6	18,9	CM65 - V50	P65-S125	65x125
EN BG MTP 50-200-NB PS	LPW 3-09	20,1	22,1	CM65 - V50	P65-S125	65x150
EN BG MTP 50-200-NA LS	11LD626/3	24	26	CM65 - V50	P65-S150	65x150
EN BG MTP 50-200-NA PS	LPW 4-09	26,8	29,5	CM65 - V50	P65-S150	65x150
EN BG MTP 50-250-225 PC	LPW 3-09	20,1	22,1	CM65-V50	P65-S125	65x125
EN BG MTP 50-250-235 LC	11LD626/3	24	26	CM65-V50	P65-S125	65x125
EN BG MTP 50-250-235 PC	LPW 4-09	26,8	29,5	CM65-V50	P65-S125	65x125
EN BG MTP 50-250-245 LC	11LD626/3	24	26	CM65 - V50	P65-S125	65x125
EN BG MTP 50-250-245 PC	LPW 4-09	26,8	29,5	CM65 - V50	P65-S125	65x125
EN BG MTP 50-250-255 VC	D703LE0	33	37	CM65 - V50	P65-S125	65x125
EN BG MTP 50-250-264 VC	D703LE0	33	37	CM65 - V50	P65-S125	65x125
EN BG MTP 50-250-264 PC	LPWT 4-09	37,5	40,2	CM65 - V50	P65-S125	65x125
EN BG MTP 50-250-NA VS	D703LE0	33	37	CM65 - V50	P65-S150	65x150
EN BG MTP 50-250-NA PS	LPWT 4-09	37,5	40,2	CM65 - V50	P65-S150	65x150
EN BG MTP 50-315-274 VC	D703LTE0	48	53	CM65-V50	P80-S125	80x125
EN BG MTP 50-315-291 VC	D703LTE0	48	53	CM65-V50	P80-S125	80x125
EN BG MTP 50-315-308 VC	D754TPE2	65	73	CM65-V50	P80-S125	80x125
EN BG MTP 65-200-185 PC	LPW 3-09	20,1	22,1	CM100-V80	P80-S200	80x200
EN BG MTP 65-200-NA VS	D703LE0	33	37	CM100-V80	P80-S200	80x200
EN BG MTP 65-200-195 LC	11LD626/3	24	26	CM100-V80	P80-S200	80x200
EN BG MTP 65-200-195 PC	LPW 4-09	26,8	29,5	CM100-V80	P80-S200	80x200
EN BG MTP 65-200-205 PC	LPW 4-09	26,8	29,5	CM100-V80	P80-S200	80x200
EN BG MTP 65-200-214 VC	D703LE0	33	37	CM100-V100	P80-S200	80x200
EN BG MTP 65-200-214 PC	LPWT 4-09	37,5	40,2	CM100-V100	P80-S200	80x200
EN BG MTP 65-250-225 VC	D703LE0	33	37	CM100-V80	P80-S200	80x200
EN BG MTP 65-250-225 PC	LPWT 4-09	37,5	40,2	CM100-V80	P80-S200	80x200

IDROFIRE BG MTP

DATI TECNICI TECHNICAL DATA

MODELLO GRUPPO	MOTORE DIESEL			KIT FLUSSIMETRO	KIT SOTTOBATTENTE	KIT SOPRABATTENTE
	DIESEL ENGINE			FLOW METER KIT	pompa principale POSITIVE HEAD KIT	pompa principale SUCTION LIFT KIT
BG MTP	mod.	kW NA	kW NB	mod.	mod.	mod.
EN BG MTP 65-250-NB VS	D703LE0	33	37	CM80-V80	P80-S150	80x150
EN BG MTP 65-250-NB PS	LPWT 4-09	37,5	40,2	CM80-V80	P80-S150	80x150
EN BG MTP 65-250-235 VC	D703LTE0	48	53	CM100-V80	P80-S200	80x200
EN BG MTP 65-250-235 PC	LPWT 4-09	37,5	40,2	CM100-V80	P80-S200	80x200
EN BG MTP 65-250-245 VC	D703LTE0	48	53	CM100-V80	P80-S200	80x200
EN BG MTP 65-250-255 VC	D703LTE0	48	53	CM100-V80	P80-S200	80x200
EN BG MTP 65-250-NOA VS	D703LTE0	48	53	CM100-V80	P80-S200	80x200
EN BG MTP 65-250-264 VC	D754TPE2	65	73	CM100-V80	P80-S200	80x200
EN BG MTP 65-250-NO VS	D703LTE0	48	53	CM100-V80	P80-S150	80x200
EN BG MTP 65-315-RCD273 VS	D754TPE2	65	73	CM100-V80	P80-S200	80x200
EN BG MTP 65-315-RBC282 VS	D754TPE2	65	73	CM100-V80	P80-S200	80x200
EN BG MTP 65-315-291 VC	D756IPE2	100	110	CM100-V80	P80-S200	80x200
EN BG MTP 65-315-308 IC	N45 MNT F41	130,5	145	CM100-V80	P80-S200	80x200
EN BG MTP 80-200-195 VC	D703LE0	33	37	CM125-V100	P100-S250	100x250
EN BG MTP 80-200-195 PC	LPWT 4-09	37,5	40,2	CM125-V100	P100-S250	100x250
EN BG MTP 80-200-205 VC	D703LTE0	48	53	CM125-V100	P100-S250	100x250
EN BG MTP 80-200-205 PC	LPWT 4-09	37,5	40,2	CM125-V100	P100-S250	100x250
EN BG MTP 80-200-214 VC	D703LTE0	48	53	CM125-V125	P100-S250	100x250
EN BG MTP 80-250-225 VC	D703LTE0	48	53	CM100-V100	P100-S200	100x250
EN BG MTP 80-250-235 VC	D703LTE0	48	53	CM125-V100	P100-S200	100x250
EN BG MTP 80-250-245 VC	D754TPE2	65	73	CM125-V100	P100-S250	100x250
EN BG MTP 80-250-255 VC	D754TPE2	65	73	CM125-V100	P100-S250	100x250
EN BG MTP 80-250-264 VC	D756IPE2	100	110	CM125-V125	P100-S250	100x250
EN BG MTP 80-250-A VS	D756IPE2	100	110	CM125-V100	P100-S200	100x250
EN BG MTP 100-200-195 VC	D703LTE0	48	53	CM125-V125	P125-S250	125x300
EN BG MTP 100-200-195 PC	LPWT 4-09	37,5	40,2	CM125-V125	P125-S250	125x300
EN BG MTP 100-200-205 VC	D703LTE0	48	53	CM125-V125	P125-S250	125x300
EN BG MTP 100-200-214 VC	D754TPE2	65	73	CM125-V125	P125-S250	125x300
EN BG MTP 100-250-225 VC	D754TPE2	65	73	CM125-V125	P125-S300	125x300
EN BG MTP 100-250-235 VC	D756IPE2	100	110	CM125-V125	P125-S300	125x300
EN BG MTP 100-250-245 VC	D756IPE2	100	110	CM125-V125	P125-S300	125x300
EN BG MTP 100-250-255 IC	N45 MNT F41	130,5	145	CM125-V125	P125-S300	125x350
EN BG MTP 100-250-264 IC	N45 MNT F41	130,5	145	CM125-V125	P125-S300	125x350
EN BG MTP 100-315-291 IC	N45MNT F41	130,5	145	CM125-V125	P150-S250	150x250
EN BG MTP 100-315-RBC292 IS	N45 MNT F41	130,5	145	CM125-V125	P125-S300	125x300
EN BG MTP 100-315-RBC296 IS	N67 MNT F42	178	197	CM125-V125	P125-S300	125x300
EN BG MTP 100-315-RBC308 IS	N67 MNT F42	178	197	CM125-V125	P125-S300	125x300
EN BG MTP 100-315-308 IC	N45 MNT F41	130,5	145	CM125-V125	P150-S300	150x300
EN BG MTP 125-200-205 VC	D754TPE2	65	73	CM200-V200	P150-S300	150x350
EN BG MTP 125-200-214 VC	D756IPE2	100	110	CM200-V200	P150-S350	150x350
EN BG MTP 125-250-RC VS	D756IPE2	100	110	CM125-V125	P125-S300	150x350
EN BG MTP 125-250-RB IS	N45 MNT F41	130,5	145	CM150-V125	P150-S300	150x350
EN BG MTP 125-250-RAB IS	N67 MNT F42	178	197	CM150-V125	P150-S350	150x350
EN BG MTP 125-250-250 IC	N45 MNT F41	130,5	145	CM200-V200	P150-S300	150x350
EN BG MTP 125-250-264 IC	N45 MNT F41	130,5	145	CM200-V200	P150-S300	150x350
EN BG MTP 125-315-RBC287 IS	N67 MNT F42	178	197	CM125-V125	P150-S300	150x350
EN BG MTP 125-315-RCD295 IS	N67 MNT F42	178	197	CM125-V125	P150-S300	150x350
EN BG MTP 125-250-278 IC	N67 MNT F42	178	197	CM200-V200	P150-S350	150x400
EN BG MTP 125-315-RBC302 IS	N67 MNT F42	178	197	CM125-V125	P150-S300	150x350
EN BG MTP 150-315-RC257 IS	N67 MNT F42	178	197	CM200-V200	P200-S400	200x400
EN BG MTP 150-315-RC266 IS	N67 MNT F42	178	197	CM200-V200	P200-S400	200x400
EN BG MTP 150-315-RCD280 IS	N67 MNT F42	200	222	CM200-V200	P200-S300	200x350
EN BG MTP 150-315-RC290 IS	N67 MNT F40	227	246	CM200-V200	P200-S400	200x450
EN BG MTP 150-315-RBC284 IS	N67 MNT F42	200	222	CM200-V200	P200-S400	200x450
EN BG MTP 150-315-RBC290 IS	N67 MNT F40	227	246	CM200-V200	P200-S400	200x450
EN BG MTP 150-315-RAB310 IS	N60 ENT F40	282	295	CM200-V200	P200-S400	200x450
EN BG MTP 150-315-RAB315 IS	N60 ENT F40	282	295	CM200-V200	P200-S400	200x450

IDROFIRE BG MTP

DIMENSIONI DIMENSION

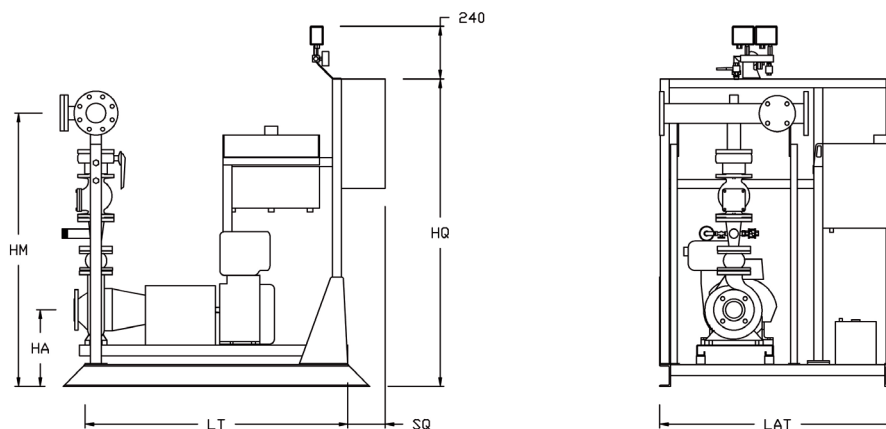

MODELLO GRUPPO	MANDATA		ASPIRAZIONE		HA	HM	LAT	LT	HQ	SQ
	KIT VLV	collettore	STB	STB						
MODEL GROUP	DELIVERY		SUCTION		HA	HM	LAT	LT	HQ	SQ
BG MTP	DN	DN	DN	DN	mm	mm	mm	mm	mm	mm
EN BG MTP 32-200-NC LS	40	DN80-F50	65	80	370	1243	1000	1100	1400	200
EN BG MTP 32-200-NB LS	40	DN80-F50	65	80	370	1243	1000	1100	1400	200
EN BG MTP 32-200-NA LS	40	DN80-F50	80	80	370	1243	1000	1100	1400	200
EN BG MTP 32-250-E LS	40	DN80-F50	80	100	390	1308	1000	1100	1400	200
EN BG MTP 32-250-225 LC	40	DN80-F50	80	100	390	1308	1000	1100	1400	200
EN BG MTP 32-250-235 LC	40	DN80-F50	80	100	390	1308	1000	1300	1400	200
EN BG MTP 32-250-245 LC	40	DN80-F50	80	100	390	1308	1000	1300	1400	200
EN BG MTP 32-250-B PS	50	DN80-F50	100	100	390	1338	1000	1400	1400	200
EN BG MTP 32-250-255 LC	40	DN80-F50	80	100	390	1308	1000	1300	1400	200
EN BG MTP 32-250-264 PC	40	DN80-F50	80	100	390	1308	1000	1400	1400	200
EN BG MTP 32-250-A LS	50	DN80-F50	100	100	434	1382	1000	1400	1400	200
EN BG MTP 40-200-185 LC	50	DN80-F50	80	100	370	1273	1000	1100	1400	200
EN BG MTP 40-200-195 LC	50	DN80-F50	80	100	370	1273	1000	1100	1400	200
EN BG MTP 40-200-205 LC	50	DN80-F50	100	100	370	1273	1000	1100	1400	200
EN BG MTP 40-200-214 LC	50	DN80-F50	100	100	370	1273	1000	1100	1400	200
EN BG MTP 40-200-NA LS	50	DN80-F50	100	100	395	1298	1000	1100	1400	200
EN BG MTP 40-250-225 LC	50	DN80-F50	100	125	390	1338	1000	1300	1400	200
EN BG MTP 40-250-235 LC	50	DN80-F50	100	125	390	1338	1000	1300	1400	200
EN BG MTP 40-250-245 PC	50	DN80-F50	100	125	390	1338	1000	1400	1400	200
EN BG MTP 40-250-255 PC	50	DN80-F50	100	125	390	1338	1000	1400	1400	200
EN BG MTP 40-250-264 LC	50	DN80-F50	100	125	434	1382	1000	1400	1400	200
EN BG MTP 40-250-264 PC	50	DN80-F50	100	125	400	1348	1100	1600	1400	200
EN BG MTP 40-315-RB300 VS	65	DN80-F50	100	125	445	1461	1100	1600	1400	200
EN BG MTP 40-315-RAB308 VS	65	DN80-F50	100	125	445	1461	1100	1600	1400	200
EN BG MTP 40-315-RAB315 VS	65	DN80-F50	100	125	445	1461	1100	1600	1400	200
EN BG MTP 50-160-174 LC	65	DN80-F50	150	150	395	1351	1000	1100	1400	200
EN BG MTP 50-200-185 LC	65	DN80-F50	125	125	370	1346	1000	1100	1400	200
EN BG MTP 50-200-195 LC	65	DN80-F50	125	125	395	1371	1000	1100	1400	200
EN BG MTP 50-200-C LS	65	DN80-F50	125	125	370	1346	1000	1100	1400	200
EN BG MTP 50-200-B LS	65	DN80-F50	100	125	395	1371	1000	1100	1400	200
EN BG MTP 50-200-205 LC	65	DN80-F50	125	125	388	1364	1000	1300	1400	200
EN BG MTP 50-200-A LS	65	DN80-F50	125	125	395	1371	1000	1100	1400	200
EN BG MTP 50-200-214 LC	65	DN80-F50	125	125	388	1364	1000	1300	1400	200
EN BG MTP 50-200-NB PS	65	DN80-F50	125	150	380	1356	1000	1400	1400	200
EN BG MTP 50-200-NA LS	65	DN80-F50	150	150	434	1410	1000	1400	1400	200
EN BG MTP 50-200-NA PS	65	DN80-F50	150	150	390	1366	1100	1600	1400	200
EN BG MTP 50-250-225 PC	65	DN80-F50	125	125	390	1391	1000	1400	1400	200
EN BG MTP 50-250-235 LC	65	DN80-F50	125	125	434	1435	1000	1400	1400	200
EN BG MTP 50-250-235 PC	65	DN80-F50	125	125	400	1401	1100	1600	1400	200

IDROFIRE BG MTP

DIMENSIONI DIMENSION

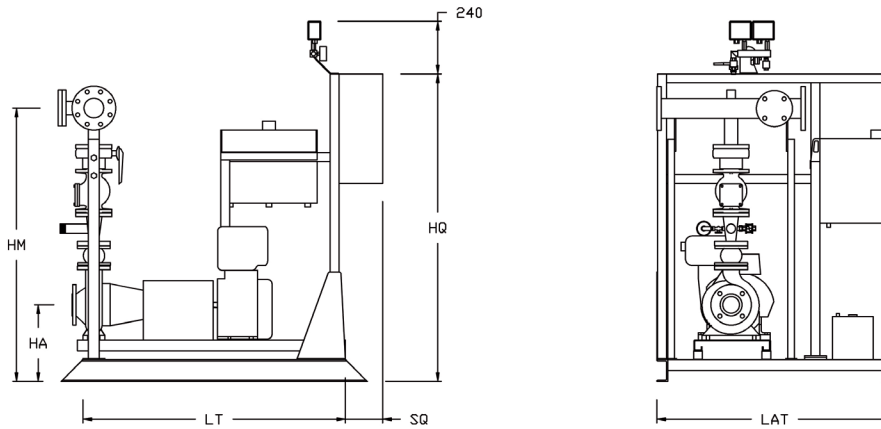

MODELLO GRUPPO	MANDATA		ASPIRAZIONE		HA	HM	LAT	LT	HQ	SQ
	KIT VLV	collettore	STB	STB						
MODEL GROUP	DELIVERY		SUCTION		HA	HM	LAT	LT	HQ	SQ
BG MTP	valves kit	manifold	posit. head	posit. head	mm	mm	mm	mm	mm	mm
	DN	DN	DN	DN						
EN BG MTP 50-250-245 LC	65	DN80-F50	125	125	434	1435	1000	1400	1400	200
EN BG MTP 50-250-245 PC	65	DN80-F50	125	125	400	1401	1100	1600	1400	200
EN BG MTP 50-250-255 VC	65	DN80-F50	125	125	400	1401	1100	1600	1400	200
EN BG MTP 50-250-264 VC	65	DN80-F50	125	125	400	1401	1100	1600	1400	200
EN BG MTP 50-250-264 PC	65	DN80-F50	125	125	400	1401	1100	1600	1400	200
EN BG MTP 50-250-NA VS	65	DN80-F50	150	150	400	1401	1100	1600	1400	200
EN BG MTP 50-250-NA PS	65	DN80-F50	150	150	400	1401	1100	1600	1400	200
EN BG MTP 50-315-274 VC	65	DN80-F50	125	125	445	1501	1100	1600	1400	200
EN BG MTP 50-315-291 VC	65	DN80-F50	125	125	445	1501	1100	1600	1400	200
EN BG MTP 50-315-308 VC	65	DN80-F50	125	125	450	1506	1200	1800	1400	200
EN BG MTP 65-200-185 PC	100	DN125-F80	200	200	390	1512	1000	1400	1400	200
EN BG MTP 65-200-NA VS	100	DN125-F80	200	200	400	1522	1100	1600	1400	200
EN BG MTP 65-200-195 LC	100	DN125-F80	200	200	434	1556	1000	1400	1400	200
EN BG MTP 65-200-195 PC	100	DN125-F80	200	200	400	1522	1100	1600	1400	200
EN BG MTP 65-200-205 PC	100	DN125-F80	200	200	400	1522	1100	1600	1400	200
EN BG MTP 65-200-214 VC	100	DN125-F80	200	200	400	1522	1100	1600	1400	200
EN BG MTP 65-200-214 PC	100	DN125-F80	200	200	400	1522	1100	1600	1400	200
EN BG MTP 65-250-225 VC	100	DN125-F80	200	200	420	1567	1100	1600	1400	200
EN BG MTP 65-250-225 PC	100	DN125-F80	200	200	420	1567	1100	1600	1400	200
EN BG MTP 65-250-NB VS	80	DN100-F80	150	150	420	1488	1100	1600	1400	200
EN BG MTP 65-250-NB PS	80	DN100-F80	150	150	420	1488	1100	1600	1400	200
EN BG MTP 65-250-235 VC	100	DN125-F80	200	200	420	1567	1100	1600	1400	200
EN BG MTP 65-250-235 PC	100	DN125-F80	200	200	420	1567	1100	1600	1400	200
EN BG MTP 65-250-245 VC	100	DN125-F80	200	200	420	1567	1100	1600	1400	200
EN BG MTP 65-250-255 VC	100	DN125-F80	200	200	420	1567	1100	1600	1400	200
EN BG MTP 65-250-NQA VS	100	DN125-F80	200	200	420	1567	1100	1600	1400	200
EN BG MTP 65-250-264 VC	100	DN125-F80	200	200	420	1567	1200	1800	1400	200
EN BG MTP 65-250-N0 VS	100	DN125-F80	150	200	420	1567	1100	1600	1400	200
EN BG MTP 65-315-RCD273 VS	100	DN125-F80	200	200	445	1622	1200	1800	1400	200
EN BG MTP 65-315-RBC282 VS	100	DN125-F80	200	200	450	1627	1200	1800	1400	200
EN BG MTP 65-315-291 VC	100	DN125-F80	200	200	450	1627	1200	2000	1400	200
EN BG MTP 65-315-308 IC	100	DN125-F80	200	200	555	1732	1400	2000	1400	200
EN BG MTP 80-200-195 VC	125	DN150-F100	250	250	400	1630	1100	1600	1400	200
EN BG MTP 80-200-195 PC	125	DN150-F100	250	250	400	1630	1100	1600	1400	200
EN BG MTP 80-200-205 VC	125	DN150-F100	250	250	400	1630	1100	1600	1400	200
EN BG MTP 80-200-205 PC	125	DN150-F100	250	250	400	1630	1100	1600	1400	200
EN BG MTP 80-200-214 VC	125	DN150-F100	250	250	400	1630	1100	1600	1400	200
EN BG MTP 80-250-225 VC	125	DN150-F100	200	250	420	1680	1100	1600	1400	200
EN BG MTP 80-250-235 VC	125	DN150-F100	200	250	420	1680	1100	1600	1400	200

IDROFIRE BG MTP

DIMENSIONI DIMENSION

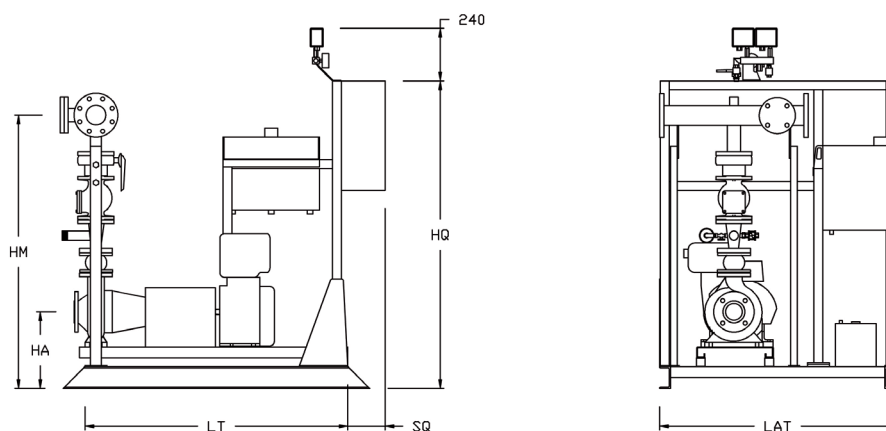

MODELLO GRUPPO	MANDATA		ASPIRAZIONE		HA	HM	LAT	LT	HQ	SQ
	KIT VLV	collettore	STB	STB						
	DELIVERY valves kit	manifold	SUCTION posit. head	posit. head						
BG MTP	DN	DN	DN	DN	mm	mm	mm	mm	mm	mm
EN BG MTP 80-250-245 VC	125	DN150-F100	250	250	420	1680	1200	1800	1400	200
EN BG MTP 80-250-255 VC	125	DN150-F100	250	250	450	1710	1200	1800	1400	200
EN BG MTP 80-250-264 VC	125	DN150-F100	250	250	450	1710	1200	2000	1400	200
EN BG MTP 80-250-A VS	125	DN150-F100	200	250	555	1815	1400	2000	1400	200
EN BG MTP 100-200-195 VC	150	DN200-F125	250	300	420	1761	1100	1600	1400	200
EN BG MTP 100-200-195 PC	150	DN200-F125	250	300	420	1761	1100	1600	1400	200
EN BG MTP 100-200-205 VC	150	DN200-F125	250	300	420	1761	1100	1600	1400	200
EN BG MTP 100-200-214 VC	150	DN200-F125	250	300	420	1761	1200	1800	1400	200
EN BG MTP 100-250-225 VC	150	DN200-F125	300	300	450	1791	1200	1800	1400	200
EN BG MTP 100-250-235 VC	150	DN200-F125	300	300	450	1791	1200	2000	1400	200
EN BG MTP 100-250-245 VC	150	DN200-F125	300	300	450	1791	1200	2000	1400	200
EN BG MTP 100-250-255 IC	150	DN200-F125	300	350	555	1896	1400	2000	1400	200
EN BG MTP 100-250-264 IC	150	DN200-F125	300	350	555	1896	1400	2000	1400	200
EN BG MTP 100-315-291 IC	150	DN200-F125	250	250	555	1931	1400	2000	1400	200
EN BG MTP 100-315-RBC292 IS	150	DN200-F125	300	300	555	1931	1400	2000	1400	200
EN BG MTP 100-315-RBC296 IS	150	DN200-F125	300	300	575	1951	1400	2000	1400	200
EN BG MTP 100-315-RBC308 IS	150	DN200-F125	300	300	575	1951	1400	2300	1400	200
EN BG MTP 100-315-308 IC	150	DN200-F125	300	300	555	1931	1400	2000	1400	200
EN BG MTP 125-200-205 VC	150	DN200-F125	300	350	470	1881	1200	1800	1400	200
EN BG MTP 125-200-214 VC	150	DN200-F125	350	350	470	1881	1200	2000	1400	200
EN BG MTP 125-250-RC VS	150	DN200-F125	300	350	470	1921	1200	2000	1400	200
EN BG MTP 125-250-RB IS	150	DN200-F125	300	350	555	2006	1400	2000	1400	200
EN BG MTP 125-250-RAB IS	150	DN200-F125	350	350	575	2026	1400	2300	1400	200
EN BG MTP 125-250-250 IC	150	DN200-F125	300	350	555	2006	1400	2000	1400	200
EN BG MTP 125-250-264 IC	150	DN200-F125	300	350	555	2006	1400	2000	1400	200
EN BG MTP 125-315-RBC287 IS	150	DN200-F125	300	350	585	2036	1400	2000	1400	200
EN BG MTP 125-315-RCD295 IS	150	DN200-F125	300	350	595	2046	1400	2300	1400	200
EN BG MTP 125-250-278 IC	150	DN200-F125	350	400	575	2026	1400	2300	1400	200
EN BG MTP 125-315-RBC302 IS	150	DN200-F125	300	350	595	2046	1400	2300	1400	200
EN BG MTP 150-315-RC257 IS	200	DN250-F200	400	400	595	2252	1400	2300	1400	200
EN BG MTP 150-315-RC266 IS	200	DN250-F200	400	400	595	2252	1400	2300	1400	200
EN BG MTP 150-315-RCD280 IS	200	DN250-F200	300	350	595	2252	1400	2300	1400	200
EN BG MTP 150-315-RC290 IS	200	DN250-F200	400	450	635	2292	1400	2300	1400	200
EN BG MTP 150-315-RBC284 IS	200	DN250-F200	400	450	595	2252	1400	2300	1400	200
EN BG MTP 150-315-RBC290 IS	200	DN250-F200	400	450	635	2292	1400	2300	1400	200
EN BG MTP 150-315-RAB310 IS	200	DN250-F200	400	450	635	2292	1400	2300	1400	200
EN BG MTP 150-315-RAB315 IS	200	DN250-F200	400	450	635	2292	1400	2300	1400	200

GRUPPI ANTINCENDIO
FIRE FIGHTING UNITS

VERTICAL TURBINE VTS

EN 12845
UNI 10779

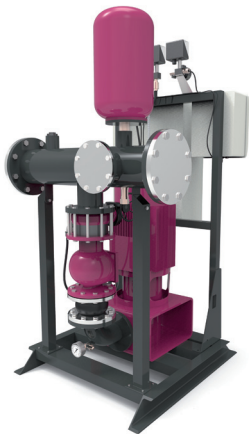

IDROFIRE VTS P1E



IDROFIRE VTS P2E

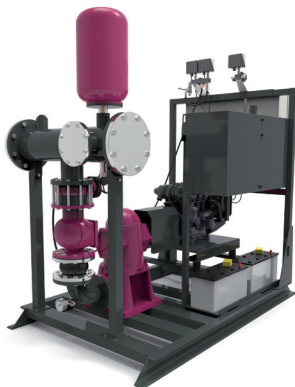

IDROFIRE VTS P1M

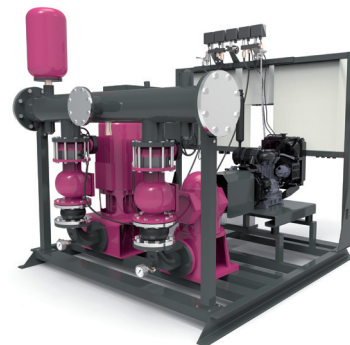

IDROFIRE VTS PEM

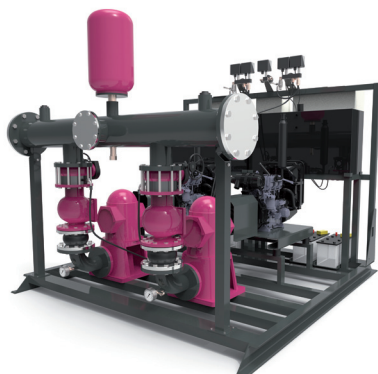

IDROFIRE VTS P2M

VOCE DI CAPITOLATO

Gruppo di pressurizzazione antincendio, tipo IDROFOGLIA a norma EN12845 modello Hydrofire VTS con pompe principali del tipo vertical turbine e pompa pilota sommersa, composto da:

Sezione Elettropompa pilota

N.1 Elettropompa pilota sommersa per il mantenimento della pressione all'interno dell'anello antincendio con elementi in fusione di acciaio inossidabile, giranti radiali, albero pompa e giunto di trasmissione in acciaio inossidabile, accoppiata a motore elettrico sommerso asincrono trifase con rotore in corto circuito, flangiatura Nema, 2 poli, grado di protezione IP 68, classe di isolamento B.

La pompa pilota è corredata in mandata di una valvole di ritegno, una valvola a sfera, un vaso di espansione 20 litri PN16, e raccordi per il collegamento al quadro di comando. La pompa è comandata in automatico da un quadro in lamiera zincata con applicato un pressostato di avviamento regolabile con grado di protezione IP55, manometro e circuito di prova del pressostato.

L'elettropompa pilota è comandata da un quadro di controllo indipendente costruito secondo norma EN12845, in lamiera verniciata con grado di protezione IP55 ad avviamento diretto, così composto:

- interruttore blocco porta fusibilità;
- contattore e relè termico
- selettore Manuale – 0 – Automatico a chiave
- lampada di avviamento
- lampada di blocco
- lampada di presenza rete
- trasformatore 400/24/12V per circuito ausiliario;
- fusibili per circuito ausiliario
- morsettiera e pressacavi
- alimentazione 400 (3F) 50 Hz

Sezione Elettropompa di servizio (o di riserva)

N.1 Elettropompa di servizio del tipo vertical turbine, con pompa verticale immersa comprensiva di valvola di fondo con filtro in aspirazione, linea d'asse con lunghezza standard di 3 mt per il collegamento del corpo pompa al gruppo di comando che consente la trasmissione del moto alle giranti, gruppo di comando per accoppiamento al motore elettrico mediante giunto elastico e motore elettrico normalizzato UNEL-IEC, del tipo verticale in forma costruttiva V1.

L'elettropompa principale è comandata da un quadro di controllo indipendente costruito secondo norma EN12845, in lamiera verniciata con grado di protezione IP55 ad avviamento diretto (fino a 11 kW) ed avviamento stella-triangolo (da 15 kW) così composto:

- interruttore blocco porta;
- scheda elettronica di gestione programmabile con spie e led di segnalazione;
- prova settimanale integrata
- presa interbloccata di servizio monofase 16 A
- selettore Manuale – 0 – Automatico a chiave
- pulsanti di marcia e arresto;
- relè mancanza fase e sequenza fase
- batteria a tampone con carica batteria
- trasformatore 400/24/12V per circuiti ausiliari;
- fusibili per circuito ausiliario
- fusibili generali
- n.3 contattori
- temporizzatore di scambio
- amperometro;
- voltmetro con commutatore voltmetrico;
- lampeggiante con avvisatore acustico
- morsettiera
- alimentazione 400 (3F+N) 50 Hz

Sezione Motopompa di servizio (o di riserva)

N.1 Motopompa di riserva del tipo vertical turbine, con pompa verticale immersa comprensiva di valvola di fondo con filtro in aspirazione, linea d'asse con lunghezza standard di 3 mt per il collegamento del corpo pompa al gruppo di comando che consente la trasmissione del moto alle giranti, gruppo di comando con rinvio ad angolo per accoppiamento al motore Diesel mediante giunto elastico e motore Diesel raffreddato ad aria fino a 30 kW e a liquido al di sopra dei 30 kW, con cinghie multiple, completo di serbatoio a caduta per un'autonomia di 6 h e doppia batteria per l'avviamento. Il gruppo motopompa sarà completo di giunti antivibranti collegati al telaio.

La motopompa è comandata da un quadro di controllo indipendente costruito secondo norma EN12845, in lamiera verniciata con grado di protezione IP55 così composto:

- interruttore blocco porta;
- scheda elettronica programmabile di comando e gestione motopompa;
- indicazioni ed allarmi sul display
- selettore Manuale – 0 – Automatico a chiave
- n.2 carica batterie 12/24V con controllo a microprocessore completi di n.2 trasformatori 230/16V e circuiti separati per l'alimentazione
- controllo batterie sul display
- fusibili per circuito ausiliario
- contagiri analogico
- prova settimanale integrata
- magnetotermico differenziale preriscaldamento
- morsettiera
- alimentazione 230 (F+N) 50 Hz

Ogni pompa principale è corredata in mandata da una curva 90° bi flangiata, giunto in gomma di compensazione, un diaframma calibrato in ottone da 3/8" per il ricircolo e lo scarico dell'aria della pompa, un manometro, una valvola di non ritorno ispezionabile, un diaframma zincato con uscita da 1/2" per il collegamento al quadro di avviamento della pompa e una valvola a farfalla d'intercettazione. Le pompe sono comandate in automatico da un pannello di controllo in lamiera zincata, collegato al diaframma mediante un tubo RILASAN 2034 15/12.5 pa12, dove si trovano 2 pressostati di avviamento regolabili con grado di protezione IP55, manometro e circuito di prova dei pressostati.

Sul collettore di mandata vi è la predisposizione per il collettore di prova, il collettore è sorretto da 2 gambe collegate al telaio principale, per garantire la stabilità e la continuità del servizio anche se si interviene su di una pompa.

Quadri, pompe e motori sono installati su un telaio realizzato in acciaio zincato.

ACCESSORI A CORREDO:

- Kit Flussimetro adeguatamente dimensionato, compostoda:
 - Flussimetro a lettura rinviata
 - Collettore in acciaio zincato
 - Valvola di intercettazione
- Quadro allarme acustico-luminoso di remotazione allarme
- Kit ricambi per motore Diesel (in accordo con la normativa EN12845)
- Kit scambiatore di calore per motore Diesel.

PROJECT DESCRIPTION

Fire Fighting Unit IDROFOGLIA with pressurization unit according to EN12845 HYDROFIRE VTS model with main vertical turbine pumps and submersible jockey pump, composed by:

Jockey Pump Section

Nr. 1 submersible jockey pump for the maintenance of the proper water pressure into the firewater ring main, with parts made of stainless steel, radiant impellers, stainless steel shaft and shaft coupling, coupled with submersible asynchronous electrical engine with squirrel-cage armature, Nema flange, 2 poles, IP68 protection, B insulation class.

The jockey pump is equipped on delivery with one check valve, one ball valve, a 20 liters expansion tank PN16, and fittings for control panel connection. The pump is automatically controlled by a galvanized control panel with an adjustable starting pressure switch IP55 protection level, gauge and pressure switch testing circuit. The jockey electric pump is controlled by an independently control panel manufactured according to EN 12845 norm, with painted IP55 protection level sheet metal, automatic starter, composed by:

- door locking switch;
- contactor and overload relay;
- manual selector lever 0 automatic with key;
- starting signal light;
- block signal light;
- main present signal light;
- transformer 400/24/12V for auxiliary circuits;
- auxiliary circuit fuses;
- terminal board and cable glands;
- power input 400 (3F) 50 Hz;

Main (or backup) Electric Pump Section

Nr. 1 vertical turbine electric pump, with submersible vertical pump with shut-down valve with aspiration filter, standard 3 mt shaft to link the pump to the drive unit, that allow the transmission of the motion to the impellers, drive unit for coupling of the electrical engine through elastic joint and normalized UNEL-IEC vertical and V1 engine, vertical and with V1.

The main electric pump is controlled by an independent control panel manufactured according to EN 12845 norm, with painted IP55 protection level sheet metal, automatic starter (until 9,2 kW) and star delta starting (from 11 kW) composed by:

- door lock switches;
- programmable electronic management with indicator led and light;
- integrated weekly test;
- interlocked mono-phase 16A service power point;
- manual selector level 0 automatic with key
- start and stop buttons;
- phase failure and phase sequence relay;
- buffer battery with charger;
- transformer 400/24/12V for auxiliary circuits;
- auxiliary circuit fuses;
- general fuses;
- nr. 3 contactors;
- swap timer;
- ampere meter;
- voltmeter with voltmeter switch;
- flashing with buzzer;
- terminal board;
- power input 400 (3F+N) 50 Hz

Main (or backup) Diesel Motor Pump Section

Nr. 1 Backup diesel Motor vertical turbine with submersible vertical pump with shut-down valve with aspiration filter, standard 3 mt shaft to link the pump to the drive unit, that allow the transmission of the motion to the impellers, right angle drive unit for coupling diesel engine through elastic joint and diesel air cooled engine up to 30 KW and liquid cooled above the 30 kW with multiple strap belts, complete with gravity tank to guarantee 6 h autonomy and double starter battery. The diesel motor pump set shall be complete of anti-vibration joints connected to frame.

The Diesel Motor pump is controlled by an independent control panel manufactured according to EN12845 norm, with painted IP55 protection level sheet metal, composed by:

- door lock switches;
- programmable electronic management with indicator led and light;
- indications and alarms on display;
- manual selector – automatic with key;
- nr. 2 battery charges 12/24V with microprocessor control complete of nr. 2 transformers 230/16V and power supply separate circuits;
- battery control on display;
- auxiliary circuit fuses;
- analogic tachometer;
- integrated weekly test;
- preheating differential magneto thermic;
- terminal board;
- power input 230(F+N) 50 Hz

Each main pump has on its delivery a 90° biflanged curve, a flanged rubber joint, a taper pipe flanged a brass orifice plate of 3/8" air pump recycle and reject, a manometer, an inspected non return valve, a galvanized diaphragm with 1/2" output for pump started panel connection and a shut-off butterfly valve. The pumps are automatically controlled by galvanized control panel, connected to the diaphragm by RILSAN 2034 15/12.5 pa12 hose, where there are 2 adjustable starting pressure with IP55 level protection, gauge and pressure circuit test. On the delivery manifold there is a predisposition for the "manifold test". The manifold is supported by two "legs" connected to the main frame to guarantee the service stability and continuity. Control panels, pumps and engines are installed on a galvanized steel frame.

ACCESSORIES:

- Flow meter Kit adequately sized, composed by:
 - Postponed reading flow meter;
 - Galvanized steel manifold;
 - Shut off valve
- Control panel for alarm maintaining with remote control. Control panel for A and B alarms grouping with the possibility to connect sirens and to interface it, trough clean contacts, with the eventual supervision system;
- Diesel engine spare parts kit (in accordance with EN12845 norm)
- Water-water diesel engine exchanger.

PRESTAZIONI POMPE PUMPS PERFORMANCES

DATI TECNICI TECHNICAL DATA

PUMP MODEL	engine power					limit HHS - HHP		hydraulic performance													
	electric	diesel			jockey	HHS - HHP		Q: l/min	250	275	300	350	400	450	500	600	700	750	900	990	
	kW	type	kW NA	kW NB	kW	mc/h	l/min.	Q: mc/h	15	16,5	18	21	24	27	30	36	42	45	54	59,4	
6G/4A	7,5	L	6,2	6,7	0,75	32	534	H:mca	50	50	50	49	48	46	44	38	29,5	24			
6G/6A	11	L	10,4	11,5	1,1	32	534		76	75	75	74	72	69	66	57	44,5	36			
6G/8A	11	L	13,6	15	1,5	32	534		101	100	100	98	96	92	88	76	59	48			
6G/10A	15	L	17	18,9	2,2	32	534		126	125	125	122	119	116	111	96	74	60			
6G/12A	18,5	L	17	18,9	2,2	32	534		151	150	149	148	143	138	133	115	89	72			
6C/4A	11	L	10,4	11,5	0,75	42	700						55	55	54	53	50	47	45	42,5	37,5
6C/6A	15	L	13,6	15	1,5	42	700						83	82	81	80	76	70	68	64	56
6C/8A	18,5	L	17	18,9	1,5	42	700						111	109	108	106	101	94	89	85	75
6C/10A	30	L	24	26	2,2	42	700						138	137	135	133	126	117	114	107	93

PUMP MODEL	engine power					limit HHS - HHP		hydraulic performance												
	electric	diesel			jockey	HHS - HHP		Q: l/min	500	600	700	800	900	1000	1200	1400	1600	1800		
	kW	type	kW NA	kW NB	kW	mc/h	l/min.	Q: mc/h	30	36	42	48	54	60	72	84	96	108		
7L/3A	11	L	10,4	11,5	0,75	54	900	H:mca	54,5	53,5	51,5	49,5	46,5	43	34,5	24,5				
7L/4A	15	L	13,6	15	1,1	54	900		73	71	69	66	62	57	46,5	32,5				
7L/5A	18,5	L	17	18,9	1,5	54	900		91	89	86	82	78	72	58	41				
7L/6A	22	L	24	26	1,5	54	900		109	107	103	99	93	86	69	49				
7L/7A	30	L	24	26	2,2	54	900		128	124	120	115	109	101	81	57				
7L/8A	30	V	33	37	2,2	54	900		146	142	137	132	124	115	93	65				
7L/9A	30	V	33	37	2,2	54	900		164	160	154	148	140	129	104	73				
7C/2A	11	L	10,4	11,5	0,75	75	1250						39	38,5	37,5	36,5	34,5	31	26,5	21
7C/3A	18,5	L	17	18,9	0,75	75	1250						58	57	56	55	52	47	40	31,5
7C/4A	22	L	24	26	1,1	75	1250					78	77	75	73	69	62	53	42	
7C/5A	30	V	33	37	1,5	75	1250					97	96	94	92	86	78	67	53	
7C/6A	37	V	33	37	1,5	75	1250					117	115	113	110	103	94	80	63	
7C/7A	37	V	48	53	2,2	75	1250					136	134	132	128	120	109	93	74	

PUMP MODEL	engine power					limit HHS - HHP		hydraulic performance														
	electric	diesel			jockey	HHS - HHP		Q: l/min	500	600	700	800	900	1000	1100	1200	1300	1400	1500	1600	1700	
	kW	type	kW NA	kW NB	kW	mc/h	l/min.	Q: mc/h	30	36	42	48	54	60	66	72	78	84	90	96	102	
8B/2A	11	L	10,4	11,5	0,75	60	1000	H:mca	50	49	47,5	46	44	42	39,5	37	34	30	25,5			
8B/3A	18,5	L	17	18,9	1,1	60	1000		75	73	71	69	66	63	59	56	50	45	38			
8B/4A	22	L	24	26	1,5	60	1000		100	98	95	92	88	84	79	75	68	60	51			
8B/5A	30	V	33	37	2,2	60	1000		125	122	119	115	110	105	99	93	85	76	64			
8B/6A	37	V	33	37	2,2	60	1000		151	147	142	138	132	126	119	110	102	90	76			
8F/2A	15	L	13,6	15	0,75	72	1200						48	47	45,5	43,5	41,5	39	36,5	34	30	26,5
8F/3A	18,5	L	17	18,9	1,1	72	1200						72	70	68	65	62	58	54	50	45	40
8F/4A	30	L	24	26	1,5	72	1200						96	94	91	87	83	78	73	67	60	53
8F/5A	30	V	33	37	1,5	72	1200						120	117	113	108	104	97	91	83	75	67
8F/6A	37	V	48	53	2,2	72	1200						144	141	136	130	124	117	109	100	90	80

PRESTAZIONI POMPE
PUMPS PERFORMANCES

DATI TECNICI TECHNICAL DATA

PUMP MODEL	engine power					limit HHS - HHP		hydraulic performance											
	electric	diesel			jockey	HHS - HHP		Q: l/min	800	1000	1200	1400	1600	1800	2000	2200	2400	2600	
	kW	type	kW NA	kW NB	kW	mc/h	l/min.	Q: mc/h	48	60	72	84	96	108	120	132	144	156	
8L/2A	15	L	13,6	15	0,75	90	1500	H:mca	46	44,5	42,5	40	36,5	32,5	27,5	21,5			
8L/3A	22	L	24	26	1,1	90	1500		69	67	64	60	55	48,5	41,5	32,5			
8L/4A	30	V	33	37	1,5	90	1500		92	89	85	80	73	65	55	43			
8L/5A	37	V	33	37	1,5	90	1500		115	112	106	100	91	81	69	54			
8L/6A	45	V	48	53	2,2	90	1500		138	134	128	119	109	97	83	65			
8C/2A	18,5	L	17	18,9	0,75	111	1850				48,5	47	45	42,5	40	36,5	32,5	28,5	
8C/3A	30	V	33	37	1,1	111	1850				73	71	68	64	59,5	55	49	42,5	
8C/4A	37	V	48	53	1,5	111	1850				97	94	90	85	80	73	65	57	
8C/5A	45	V	48	53	2,2	111	1850				121	118	113	107	100	91	82	71	
8C/6A	55	V	65	73	2,2	111	1850				145	141	135	128	119	109	98	85	

PUMP MODEL	engine power					limit HHS - HHP		hydraulic performance										
	electric	diesel			jockey	HHS - HHP		Q: l/min	2500	3000	3500	4000	4500	5000	5500	6000	6500	7000
	kW	type	kW NA	kW NB	kW	mc/h	l/min.	Q: mc/h	150	180	210	240	270	300	330	360	390	420
10F/1B	37	V	33	37	0,75	275	4584	H:mca	37	36	34	32,5	30,5	28,5	25,5	23	20	15,5
10F/1A	45	V	48	53	0,75	275	4584		41	39,5	38	36,5	34,5	32,5	30	27	24,5	20,5
10F/2E	45	V	48	53	0,75	240	4000		55	52	48	44	39,5	34	26,5	18,5		
10F/2CD	55	V	65	73	1,1	252	4200		64	61	57	54	49,5	45	39	32,5	24,5	
10F/2BC	75	V	65	73	1,1	252	4200		71	68	65	61	57	53	47	41,5	34,5	
10F/3CD	90	V	100	110	1,5	252	4200		95	91	86	80	74	67	58	49	37	
10F/3B	110	V	100	110	1,5	275	4584		111	108	103	97	92	85	77	69	59	47

PUMP MODEL	engine power					limit HHS - HHP		hydraulic performance								
	electric	diesel			jockey	HHS - HHP		Q: l/min	2400	3000	3500	4000	4500	5000	5500	5700
	kW	type	kW NA	kW NB	kW	mc/h	l/min.	Q: mc/h	144	180	213	240	270	300	330	342
12B/1B	37	V	48	53	0,75	213	3550	H:mca	53	50	46	42	37	31	23,5	
12B/1A	45	V	48	53	0,75	213	3550		58	55	51	47	42	36,5	29	26,5
12B/2C	75	V	65	73	1,5	213	3550		94	89	81	72	62	49,5		
12B/2B	75	V	100	110	1,5	213	3550		106	100	92	84	74	63	47	
12B/3C	110	V	100	110	2,2	213	3550		141	133	121	108	93	74		

IDROFIRE VTS P1E

N.1 ELETTROPOMPA DI SERVIZIO + PILOTA
NR.1 MAIN ELECTRIC PUMP + JOCKEY PUMP



ELENCO COMPONENTI COMPONENT LIST

- | | |
|---|---|
| <ol style="list-style-type: none"> 1. Pompa di servizio del tipo verticale 2. Linea d'asse 3. Gruppo di comando per collegamento tra pompa e motore 4. Motore elettrico 5. Elettropompa pilota sommersa 6. Valvola di ritegno a clapet 7. Valvola di intercettazione lucchettabile 8. Valvola di ritegno 9. Valvola di intercettazione a sfera con leva 10. Collettore di mandata reversibile completo di flangia cieca 11. Derivazione per collettore di prova di portata 12. Predisposizione per kit sprinkler 13. Kit avviamento per pompe principali composto da 2 pressostati 2-14 bar con pulsante di prova integrato, 1 manometro 0-16 bar e circuito by-pass 14. Kit avviamento per pompa pilota composto da 1 pressostato con pulsante di prova integrato, 1 manometro 15. Quadri elettrici di comando (uno per ogni pompa) 16. Kit diaframma di ricircolo completo di indicatore visivo di flusso 17. Manometro 0-16 bar 18. Serbatoio Autoclave 24 lt PN16 19. Giunto di compensazione in gomma 20. Curva bi flangiata 90° 21. Telaio | <ol style="list-style-type: none"> 1. Service vertical pump 2. Line shaft 3. Drive unit to link pump and engine 4. Electrical engine 5. Jockey submersible pump 6. Swing Check Valve ("Clapet" Valve) 7. Shut-off valve lockable 8. Check valve 9. Ball valve with level 10. Reversible delivery manifold with blind flange 11. Shunt for flow meter 12. Predisposition for sprinkler kit 13. Starting kit for main pump composed by 2 pressure switch 2-14 bar with integrated test button, 1 pressure gauge 0-16 bar and by-pass circuit 14. Starting kit for jockey electric pump composed by 1 pressure switch with integrated test button, 1 pressure gauge 15. Electrical control panels (one for each pump) 16. Kit recycling diaphragm complete with visual flow indicator 17. Pressure gauge 0-16 bar 18. Diaphragm pressure vessel 24LT PN16 19. Rubber strain neutralizer 20. Biflanged 90° curve 21. Frame |
|---|---|

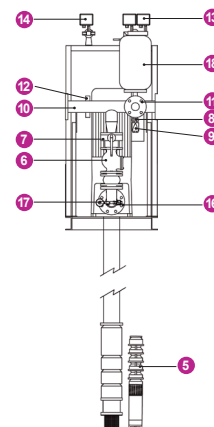
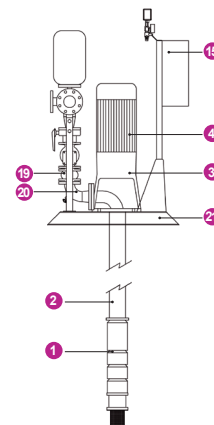

DROFIRE VTS P1E

DATI TECNICI TECHNICAL DATA

MODELLO GRUPPO	ELETTROPOMPA			ELETTROPOMPA PILOTA		LINEA D'ASSE	KIT FLUSSIMETRO		
	motore elettrico	gruppo di comando		JOCKEY PUMP				LINESHAFT	FLOW METER KIT
	ELECTRIC PUMP	drive unit on the surface							
MODEL GROUP	electric engine								
VTS P1E	kW	mod.	DN	mod.	kW	mod.	mod.		
EN VTS P1E 6G/4A EC+S4/11	7,5	E13/38/3L/20A	80	S4/11	0,75	LA3/20	CM50 - V50		
EN VTS P1E 6G/6A EC+S4/16	11	E18/42/3L/20A	80	S4/16	1,1	LA3/20	CM50 - V50		
EN VTS P1E 6G/8A EC+S4/21	11	E18/42/3L/20A	80	S4/21	1,5	LA3/20	CM50 - V50		
EN VTS P1E 6G/10A EC+S4/32	15	E18/42/3L/20A	80	S4/32	2,2	LA3/20	CM50 - V50		
EN VTS P1E 6G/12A EC+S4/32	18,5	E18/42/3L/20A	80	S4/32	2,2	LA3/20	CM50 - V50		
EN VTS P1E 6C/4A EC+S4/11	11	E18/42/3L/20A	80	S4/11	0,75	LA3/20	CM65 - V50		
EN VTS P1E 6C/6A EC+S4/21	15	E18/42/3L/20A	80	S4/21	1,5	LA3/20	CM65 - V50		
EN VTS P1E 6C/8A EC+S4/21	18,5	E18/48/3L/20A	80	S4/21	1,5	LA3/20	CM65 - V50		
EN VTS P1E 6C/10A EC+S4/32	30	E20/55/3/24	100	S4/32	2,2	LA3/24	CM65 - V50		
EN VTS P1E 7L/3A EC+S4/11	11	E18/42/3L/20A	80	S4/11	0,75	LA3/20	CM65 - V65		
EN VTS P1E 7L/4A EC+S4/16	15	E18/42/3L/20A	80	S4/16	1,1	LA3/20	CM65 - V65		
EN VTS P1E 7L/5A EC+S4/21	18,5	E18/42/3L/20A	80	S4/21	1,5	LA3/20	CM65 - V65		
EN VTS P1E 7L/6A EC+S4/21	22	E18/48/3L/20A	80	S4/21	1,5	LA3/20	CM65 - V65		
EN VTS P1E 7L/7A EC+S4/32	30	E20/55/3/24	100	S4/32	2,2	LA3/24	CM65 - V65		
EN VTS P1E 7L/8A EC+S4/32	30	E20/55/3/24	100	S4/32	2,2	LA3/24	CM65 - V65		
EN VTS P1E 7L/9A EC+S4/32	30	E20/55/3/24	100	S4/32	2,2	LA3/24	CM65 - V65		
EN VTS P1E 7C/2A EC+S4/11	11	E18/42/4L/20A	100	S4/11	0,75	LA4/20	CM80 - V65		
EN VTS P1E 7C/3A EC+S4/11	18,5	E18/42/4L/20A	100	S4/11	0,75	LA4/20	CM80 - V65		
EN VTS P1E 7C/4A EC+S4/16	22	E18/48/4L/20A	100	S4/16	1,1	LA4/20	CM80 - V65		
EN VTS P1E 7C/5A EC+S4/21	30	E20/55/4/24	100	S4/21	1,5	LA4/24	CM80 - V65		
EN VTS P1E 7C/6A EC+S4/21	37	E20/55/4/24	100	S4/21	1,5	LA4/24	CM80 - V65		
EN VTS P1E 7C/7A EC+S4/32	37	E22/55/4/24	100	S4/32	2,2	LA4/24	CM80 - V65		
EN VTS P1E 8B/2A EC+S4/11	11	E18/42/3L/20A	80	S4/11	0,75	LA3/20	CM65 - V65		
EN VTS P1E 8B/3A EC+S4/16	18,5	E18/42/3L/20A	80	S4/16	1,1	LA3/20	CM65 - V65		
EN VTS P1E 8B/4A EC+S4/21	22	E18/48/3L/20A	80	S4/21	1,5	LA3/20	CM65 - V65		
EN VTS P1E 8B/5A EC+S4/32	30	E20/55/3/24	100	S4/32	2,2	LA3/24	CM65 - V65		
EN VTS P1E 8B/6A EC+S4/32	37	E20/55/3/24	100	S4/32	2,2	LA3/24	CM65 - V65		
EN VTS P1E 8F/2A EC+S4/11	15	E18/42/4L/20A	100	S4/11	0,75	LA4/20	CM80 - V65		
EN VTS P1E 8F/3A EC+S4/16	18,5	E18/42/4L/20A	100	S4/16	1,1	LA4/20	CM80 - V65		
EN VTS P1E 8F/4A EC+S4/21	30	E20/55/4/24	100	S4/21	1,5	LA4/24	CM80 - V65		
EN VTS P1E 8F/5A EC+S4/21	30	E20/55/4/24	100	S4/21	1,5	LA4/24	CM80 - V65		
EN VTS P1E 8F/6A EC+S4/32	37	E20/55/4/24	100	S4/32	2,2	LA4/24	CM80 - V65		
EN VTS P1E 8L/2A EC+S4/11	15	E18/42/5/20A	125	S4/11	0,75	LA5/20	CM80 - V80		
EN VTS P1E 8L/3A EC+S4/16	22	E18/48/5/20A	125	S4/16	1,1	LA5/20	CM80 - V80		
EN VTS P1E 8L/4A EC+S4/21	30	E20/55/5/24	125	S4/21	1,5	LA5/24	CM80 - V80		
EN VTS P1E 8L/5A EC+S4/21	37	E20/55/5/24	125	S4/21	1,5	LA5/24	CM80 - V80		
EN VTS P1E 8L/6A EC+S4/32	45	E22/55/5/30	125	S4/32	2,2	LA5/24	CM80 - V80		
EN VTS P1E 8C/2A EC+S4/11	18,5	E18/42/5/20A	125	S4/11	0,75	LA5/20	CM100 - V80		
EN VTS P1E 8C/3A EC+S4/16	30	E20/55/5/24	125	S4/16	1,1	LA5/24	CM100 - V80		
EN VTS P1E 8C/4A EC+S4/21	37	E22/55/5/30	125	S4/21	1,5	LA5/24	CM100 - V80		
EN VTS P1E 8C/5A EC+S4/32	45	E28/60/5/30	150	S4/32	2,2	LA5/30	CM100 - V80		
EN VTS P1E 8C/6A EC+S4/32	55	E28/60/5/30	150	S4/32	2,2	LA5/30	CM100 - V80		
EN VTS P1E 10F/1B EC+S4/11	37	E20/55/6/24	150	S4/11	0,75	LA6/24	CM150 - V125		
EN VTS P1E 10F/1A EC+S4/11	45	E22/55/6/30	150	S4/11	0,75	LA6/30	CM150 - V125		
EN VTS P1E 10F/2E EC+S4/11	45	E22/55/6/30	150	S4/11	0,75	LA6/30	CM150 - V125		
EN VTS P1E 10F/2CD EC+S4/16	55	E28/60/6/30	150	S4/16	1,1	LA6/30	CM150 - V125		
EN VTS P1E 10F/2BC EC+S4/16	75	E28/65A/6/30	150	S4/16	1,1	LA6/30	CM150 - V125		
EN VTS P1E 10F/3CD EC+S4/21	90	E28/65A/6/30	150	S4/21	1,5	LA6/30	CM150 - V125		
EN VTS P1E 10F/3B EC+S4/21	110	E28/65A/6/30	150	S4/21	1,5	LA6/30	CM150 - V125		
EN VTS P1E 12B/1B EC+S4/11	37	E20/55/7/30	175	S4/11	0,75	LA7/30	CM125 - V125		
EN VTS P1E 12B/1A EC+S4/11	45	E22/55/7/30	175	S4/11	0,75	LA7/30	CM125 - V125		
EN VTS P1E 12B/2C EC+S4/21	75	E28/65A/7/30	200	S4/21	1,5	LA7/30	CM125 - V125		
EN VTS P1E 12B/2B EC+S4/21	75	E28/65A/7/30	200	S4/21	1,5	LA7/30	CM125 - V125		
EN VTS P1E 12B/3C EC+S4/32	110	E28/65A/7/35	200	S4/32	2,2	LA7/30	CM125 - V125		

IDROFIRE VTS P1E

DIMENSIONI DIMENSIONS

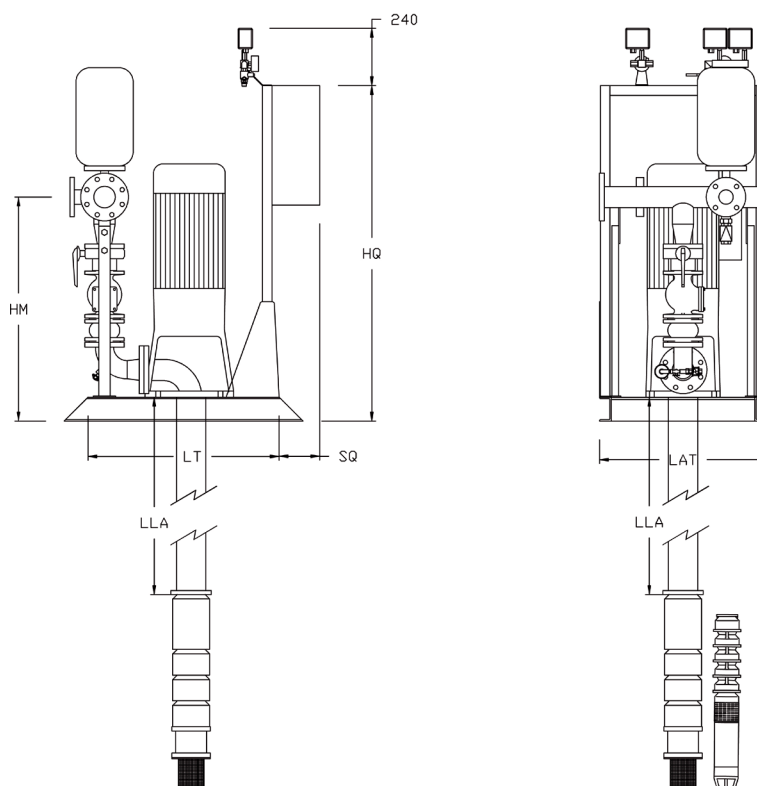

MODELLO GRUPPO	MANDATA kit valvole	collettore	PILOTA	HM	LAT	LT	LC	HQ	SQ	LLA
MODEL GROUP	DELIVERY valves kit	manifold	JOCKEY PUMP	HM	LAT	LT	LC	HQ	SQ	LLA
VTS P1E	DN	DN	DN AxM	mm	mm	mm	mm	mm	mm	mm
EN VTS P1E 6G/4A EC+S4/11	50	80 - F50	1¼"	997	700	800	700	1400	230	3050
EN VTS P1E 6G/6A EC+S4/16	50	80 - F50	1¼"	997	700	800	700	1400	230	3050
EN VTS P1E 6G/8A EC+S4/21	50	80 - F50	1¼"	997	700	800	700	1400	230	3050
EN VTS P1E 6G/10A EC+S4/32	50	80 - F50	1¼"	997	700	800	700	1400	230	3050
EN VTS P1E 6G/12A EC+S4/32	50	80 - F50	1¼"	997	700	800	700	1400	230	3050
EN VTS P1E 6C/4A EC+S4/11	65	80 - F50	1¼"	1050	700	800	700	1400	230	3050
EN VTS P1E 6C/6A EC+S4/21	65	80 - F50	1¼"	1050	700	800	700	1400	230	3050
EN VTS P1E 6C/8A EC+S4/21	65	80 - F50	1¼"	1050	700	900	700	1400	230	3050
EN VTS P1E 6C/10A EC+S4/32	65	80 - F50	1¼"	1031	800	900	800	1400	230	3050
EN VTS P1E 7L/3A EC+S4/11	80	100 - F65	1¼"	1047	700	800	700	1400	230	3050
EN VTS P1E 7L/4A EC+S4/16	80	100 - F65	1¼"	1047	700	800	700	1400	230	3050
EN VTS P1E 7L/5A EC+S4/21	80	100 - F65	1¼"	1047	700	800	700	1400	230	3050
EN VTS P1E 7L/6A EC+S4/21	80	100 - F65	1¼"	1047	700	900	700	1400	230	3050
EN VTS P1E 7L/7A EC+S4/32	80	100 - F65	1¼"	1047	800	1100	800	1400	230	3050
EN VTS P1E 7L/8A EC+S4/32	80	100 - F65	1¼"	1047	800	1100	800	1400	230	3050
EN VTS P1E 7L/9A EC+S4/32	80	100 - F65	1¼"	1047	800	1100	800	1400	230	3050
EN VTS P1E 7C/2A EC+S4/11	80	100 - F65	1¼"	1047	700	900	700	1400	230	3050
EN VTS P1E 7C/3A EC+S4/11	80	100 - F65	1¼"	1047	700	900	700	1400	230	3050
EN VTS P1E 7C/4A EC+S4/16	80	100 - F65	1¼"	1047	700	900	700	1400	230	3050
EN VTS P1E 7C/5A EC+S4/21	80	100 - F65	1¼"	1047	800	1100	800	1400	230	3050
EN VTS P1E 7C/6A EC+S4/21	80	100 - F65	1¼"	1047	800	1100	800	1400	230	3050
EN VTS P1E 7C/7A EC+S4/32	80	100 - F65	1¼"	1047	800	1100	800	1400	230	3050
EN VTS P1E 8B/2A EC+S4/11	80	100 - F65	1¼"	1047	700	800	700	1400	230	3050
EN VTS P1E 8B/3A EC+S4/16	80	100 - F65	1¼"	1047	700	800	700	1400	230	3050
EN VTS P1E 8B/4A EC+S4/21	80	100 - F65	1¼"	1047	700	900	700	1400	230	3050
EN VTS P1E 8B/5A EC+S4/32	80	100 - F65	1¼"	1047	800	1100	800	1400	230	3050
EN VTS P1E 8B/6A EC+S4/32	80	100 - F65	1¼"	1047	800	1100	800	1400	230	3050

IDROFIRE VTS P1E

DIMENSIONI DIMENSIONS

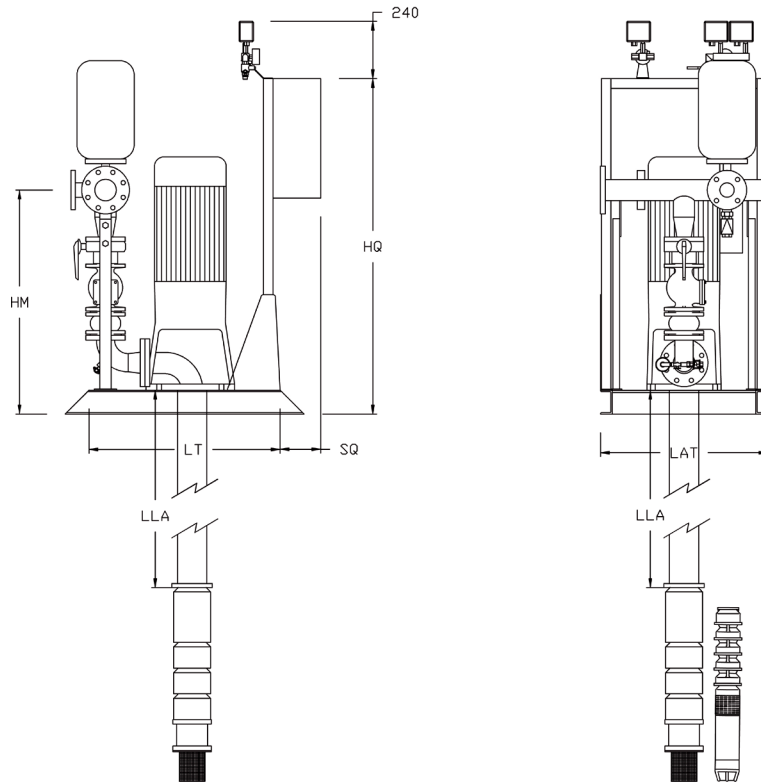

MODELLO GRUPPO	MANDATA kit valvole	collettore	PILOTA	HM	LAT	LT	LC	HQ	SQ	LLA
MODEL GROUP	DELIVERY valves kit	manifold	JOCKEY PUMP	HM	LAT	LT	LC	HQ	SQ	LLA
VTS P1E	DN	DN	DN AxM	mm	mm	mm	mm	mm	mm	mm
EN VTS P1E 8F/2A EC+S4/11	80	100 - F65	1¼"	1047	700	900	700	1400	230	3050
EN VTS P1E 8F/3A EC+S4/16	80	100 - F65	1¼"	1047	700	900	700	1400	230	3050
EN VTS P1E 8F/4A EC+S4/21	80	100 - F65	1¼"	1047	800	1100	800	1400	230	3050
EN VTS P1E 8F/5A EC+S4/21	80	100 - F65	1¼"	1047	800	1100	800	1400	230	3050
EN VTS P1E 8F/6A EC+S4/32	80	100 - F65	1¼"	1047	800	1100	800	1400	230	3050
EN VTS P1E 8L/2A EC+S4/11	100	125 - F80	1¼"	1169	700	900	700	1400	230	3050
EN VTS P1E 8L/3A EC+S4/16	100	125 - F80	1¼"	1169	700	900	700	1400	230	3050
EN VTS P1E 8L/4A EC+S4/21	100	125 - F80	1¼"	1199	800	1100	800	1400	230	3050
EN VTS P1E 8L/5A EC+S4/21	100	125 - F80	1¼"	1199	800	1100	800	1400	230	3050
EN VTS P1E 8L/6A EC+S4/32	100	125 - F80	1¼"	1199	800	1100	800	1400	230	3050
EN VTS P1E 8C/2A EC+S4/11	100	125 - F80	1¼"	1169	700	900	700	1400	230	3050
EN VTS P1E 8C/3A EC+S4/16	100	125 - F80	1¼"	1199	800	1100	800	1400	230	3050
EN VTS P1E 8C/4A EC+S4/21	100	125 - F80	1¼"	1199	800	1100	800	1400	230	3050
EN VTS P1E 8C/5A EC+S4/32	100	125 - F80	1¼"	1189	1000	1300	1000	1400	230	3050
EN VTS P1E 8C/6A EC+S4/32	100	125 - F80	1¼"	1189	1000	1300	1000	1400	230	3050
EN VTS P1E 10F/1B EC+S4/11	150	200 - F125	1¼"	1464	800	1100	800	1400	230	3050
EN VTS P1E 10F/1A EC+S4/11	150	200 - F125	1¼"	1464	800	1100	800	1400	230	3050
EN VTS P1E 10F/2E EC+S4/11	150	200 - F125	1¼"	1464	800	1100	800	1400	230	3050
EN VTS P1E 10F/2CD EC+S4/16	150	200 - F125	1¼"	1454	1000	1300	1000	1400	230	3050
EN VTS P1E 10F/2BC EC+S4/16	150	200 - F125	1¼"	1454	1000	1300	1000	1400	330	3050
EN VTS P1E 10F/3CD EC+S4/21	150	200 - F125	1¼"	1454	1100	1300	1100	1400	330	3050
EN VTS P1E 10F/3B EC+S4/21	150	200 - F125	1¼"	1454	1100	1300	1100	1400	330	3050
EN VTS P1E 12B/1B EC+S4/11	150	200 - F125	1¼"	1464	800	1100	800	1400	230	3050
EN VTS P1E 12B/1A EC+S4/11	150	200 - F125	1¼"	1464	800	1100	800	1400	230	3050
EN VTS P1E 12B/2C EC+S4/21	150	200 - F125	1¼"	1454	1000	1300	1000	1400	330	3050
EN VTS P1E 12B/2B EC+S4/21	150	200 - F125	1¼"	1454	1000	1300	1000	1400	330	3050
EN VTS P1E 12B/3C EC+S4/32	150	200 - F125	1¼"	1454	1100	1300	1100	1400	330	3050

IDROFIRE VTS P2E

N.1 ELETTROPOMPA DI SERVIZIO + N.1 ELETTROPOMPA DI RISERVA + PILOTA
 NR.1 MAIN ELECTRIC PUMP + NR.1 BACKUP ELECTRIC PUMP + JOCKEY PUMP

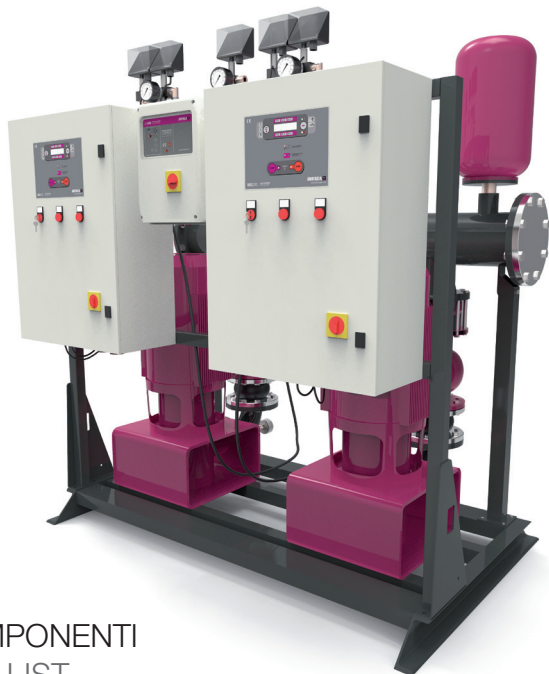

ELENCO COMPONENTI COMPONENT LIST

- | | |
|---|--|
| <ol style="list-style-type: none"> 1. Pompa di servizio del tipo verticale 1A. Pompa di riserva del tipo verticale 2. Linea d'asse per pompa di servizio e pompa di riserva 3. Gruppo di comando per collegamento tra pompa e motore (servizio e riserva) 4. Motore elettrico per pompa di servizio e pompa di riserva 5. Elettropompa pilota sommersa 6. Valvola di ritegno a clapet 7. Valvola di intercettazione lucchettabile 8. Valvola di ritegno 9. Valvola di intercettazione a sfera con leva 10. Collettore di mandata reversibile completo di flangia cieca 11. Derivazione per collettore di prova di portata 12. Predisposizione per kit sprinkler 13. Kit avviamento per pompe principali composto da 2 pressostati 2-14 bar con pulsante di prova integrato, 1 manometro 0-16 bar e circuito by-pass 14. Kit avviamento per pompa pilota composto da 1 pressostato con pulsante di prova integrato, 1 manometro; 15. Quadri elettrici di comando (uno per ogni pompa) 16. Kit diaframma di ricircolo completo di indicatore visivo di flusso 17. Manometro 0-16 bar 18. Serbatoio Autoclave 24 lt PN16 19. Giunto di compensazione in gomma 20. Curva 90° biflangiata 21. Telaio | <ol style="list-style-type: none"> 1. Vertical service pump 1A. Backup vertical pump 2. Line shaft for service pump and backup pump 3. Drive unit to link pump and engine (service and backup) 4. Electrical engine for service pump and backup pump 5. Jockey submersible pump 6. Swing Check Valve ("Clapet" Valve) 7. Shut-off valve lockable 8. Check valve 9. Ball valve with level 10. Reversible delivery manifold with blind flange 11. Shunt for flow meter 12. Predisposition for sprinkler kit 13. Starting kit for main pump composed by 2 pressure switch 2-14 bar with integrated test button, 1 pressure gauge 0-16 bar and by-pass circuit 14. Starting kit for jockey electric pump composed by 1 pressure switch with integrated test button, 1 pressure gauge 15. Electrical control panels (one for each pump) 16. Kit recycling diaphragm complete with visual flow indicator 17. Pressure gauge 0-16 bar 18. Diaphragm pressure vessel 24LT PN16 19. Rubber strain neutralizer 20. Biflanged 90° curve 21. Frame |
|---|--|

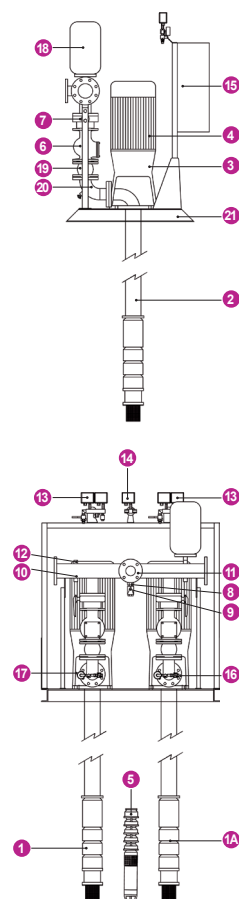

IDROFIRE VTS P2E

DATI TECNICI TECHNICAL DATA

MODELLO GRUPPO	ELETTROPOMPA			ELETTROPOMPA PILOTA		LINEA D'ASSE	KIT FLUSSIMETRO
	motore elettrico	gruppo di comando		JOCKEY PUMP		LINESHAFT	FLOW METER KIT
	ELECTRIC PUMP electric engine	drive unit on the surface					
VTS P2E	kW	mod.	DN	mod.	kW	mod.	mod.
EN VTS P2E 6G/4A EC+S4/11	7,5	E13/38/3L/20A	80	S4/11	0,75	LA3/20	CM50 - V50
EN VTS P2E 6G/6A EC+S4/16	11	E18/42/3L/20A	80	S4/16	1,1	LA3/20	CM50 - V50
EN VTS P2E 6G/8A EC+S4/21	11	E18/42/3L/20A	80	S4/21	1,5	LA3/20	CM50 - V50
EN VTS P2E 6G/10A EC+S4/32	15	E18/42/3L/20A	80	S4/32	2,2	LA3/20	CM50 - V50
EN VTS P2E 6G/12A EC+S4/32	18,5	E18/42/3L/20A	80	S4/32	2,2	LA3/20	CM50 - V50
EN VTS P2E 6C/4A EC+S4/11	11	E18/42/3L/20A	80	S4/11	0,75	LA3/20	CM65 - V50
EN VTS P2E 6C/6A EC+S4/21	15	E18/42/3L/20A	80	S4/21	1,5	LA3/20	CM65 - V50
EN VTS P2E 6C/8A EC+S4/21	18,5	E18/48/3L/20A	80	S4/21	1,5	LA3/20	CM65 - V50
EN VTS P2E 6C/10A EC+S4/32	30	E20/55/3/24	100	S4/32	2,2	LA3/24	CM65 - V50
EN VTS P2E 7L/3A EC+S4/11	11	E18/42/3L/20A	80	S4/11	0,75	LA3/20	CM65 - V65
EN VTS P2E 7L/4A EC+S4/16	15	E18/42/3L/20A	80	S4/16	1,1	LA3/20	CM65 - V65
EN VTS P2E 7L/5A EC+S4/21	18,5	E18/42/3L/20A	80	S4/21	1,5	LA3/20	CM65 - V65
EN VTS P2E 7L/6A EC+S4/21	22	E18/48/3L/20A	80	S4/21	1,5	LA3/20	CM65 - V65
EN VTS P2E 7L/7A EC+S4/32	30	E20/55/3/24	100	S4/32	2,2	LA3/24	CM65 - V65
EN VTS P2E 7L/8A EC+S4/32	30	E20/55/3/24	100	S4/32	2,2	LA3/24	CM65 - V65
EN VTS P2E 7L/9A EC+S4/32	30	E20/55/3/24	100	S4/32	2,2	LA3/24	CM65 - V65
EN VTS P2E 7C/2A EC+S4/11	11	E18/42/4L/20A	100	S4/11	0,75	LA4/20	CM80 - V65
EN VTS P2E 7C/3A EC+S4/11	18,5	E18/42/4L/20A	100	S4/11	0,75	LA4/20	CM80 - V65
EN VTS P2E 7C/4A EC+S4/16	22	E18/48/4L/20A	100	S4/16	1,1	LA4/20	CM80 - V65
EN VTS P2E 7C/5A EC+S4/21	30	E20/55/4/24	100	S4/21	1,5	LA4/24	CM80 - V65
EN VTS P2E 7C/6A EC+S4/21	37	E20/55/4/24	100	S4/21	1,5	LA4/24	CM80 - V65
EN VTS P2E 7C/7A EC+S4/32	37	E22/55/4/24	100	S4/32	2,2	LA4/24	CM80 - V65
EN VTS P2E 8B/2A EC+S4/11	11	E18/42/3L/20A	80	S4/11	0,75	LA3/20	CM65 - V65
EN VTS P2E 8B/3A EC+S4/16	18,5	E18/42/3L/20A	80	S4/16	1,1	LA3/20	CM65 - V65
EN VTS P2E 8B/4A EC+S4/21	22	E18/48/3L/20A	80	S4/21	1,5	LA3/20	CM65 - V65
EN VTS P2E 8B/5A EC+S4/32	30	E20/55/3/24	100	S4/32	2,2	LA3/24	CM65 - V65
EN VTS P2E 8B/6A EC+S4/32	37	E20/55/3/24	100	S4/32	2,2	LA3/24	CM65 - V65
EN VTS P2E 8F/2A EC+S4/11	15	E18/42/4L/20A	100	S4/11	0,75	LA4/20	CM80 - V65
EN VTS P2E 8F/3A EC+S4/16	18,5	E18/42/4L/20A	100	S4/16	1,1	LA4/20	CM80 - V65
EN VTS P2E 8F/4A EC+S4/21	30	E20/55/4/24	100	S4/21	1,5	LA4/24	CM80 - V65
EN VTS P2E 8F/5A EC+S4/21	30	E20/55/4/24	100	S4/21	1,5	LA4/24	CM80 - V65
EN VTS P2E 8F/6A EC+S4/32	37	E20/55/4/24	100	S4/32	2,2	LA4/24	CM80 - V65
EN VTS P2E 8L/2A EC+S4/11	15	E18/42/5/20A	125	S4/11	0,75	LA5/20	CM80 - V80
EN VTS P2E 8L/3A EC+S4/16	22	E18/48/5/20A	125	S4/16	1,1	LA5/20	CM80 - V80
EN VTS P2E 8L/4A EC+S4/21	30	E20/55/5/24	125	S4/21	1,5	LA5/24	CM80 - V80
EN VTS P2E 8L/5A EC+S4/21	37	E20/55/5/24	125	S4/21	1,5	LA5/24	CM80 - V80
EN VTS P2E 8L/6A EC+S4/32	45	E22/55/5/30	125	S4/32	2,2	LA5/24	CM80 - V80
EN VTS P2E 8C/2A EC+S4/11	18,5	E18/42/5/20A	125	S4/11	0,75	LA5/20	CM100 - V80
EN VTS P2E 8C/3A EC+S4/16	30	E20/55/5/24	125	S4/16	1,1	LA5/24	CM100 - V80
EN VTS P2E 8C/4A EC+S4/21	37	E22/55/5/30	125	S4/21	1,5	LA5/24	CM100 - V80
EN VTS P2E 8C/5A EC+S4/32	45	E28/60/5/30	150	S4/32	2,2	LA5/30	CM100 - V80
EN VTS P2E 8C/6A EC+S4/32	55	E28/60/5/30	150	S4/32	2,2	LA5/30	CM100 - V80
EN VTS P2E 10F/1B EC+S4/11	37	E20/55/6/24	150	S4/11	0,75	LA6/24	CM150 - V125
EN VTS P2E 10F/1A EC+S4/11	45	E22/55/6/30	150	S4/11	0,75	LA6/30	CM150 - V125
EN VTS P2E 10F/2E EC+S4/11	45	E22/55/6/30	150	S4/11	0,75	LA6/30	CM150 - V125
EN VTS P2E 10F/2CD EC+S4/16	55	E28/60/6/30	150	S4/16	1,1	LA6/30	CM150 - V125
EN VTS P2E 10F/2BC EC+S4/16	75	E28/65A/6/30	150	S4/16	1,1	LA6/30	CM150 - V125
EN VTS P2E 10F/3CD EC+S4/21	90	E28/65A/6/30	150	S4/21	1,5	LA6/30	CM150 - V125
EN VTS P2E 10F/3B EC+S4/21	110	E28/65A/6/30	150	S4/21	1,5	LA6/30	CM150 - V125
EN VTS P2E 12B/1B EC+S4/11	37	E20/55/7/30	175	S4/11	0,75	LA7/30	CM125 - V125
EN VTS P2E 12B/1A EC+S4/11	45	E22/55/7/30	175	S4/11	0,75	LA7/30	CM125 - V125
EN VTS P2E 12B/2C EC+S4/21	75	E28/65A/7/30	200	S4/21	1,5	LA7/30	CM125 - V125
EN VTS P2E 12B/2B EC+S4/21	75	E28/65A/7/30	200	S4/21	1,5	LA7/30	CM125 - V125
EN VTS P2E 12B/3C EC+S4/32	110	E28/65A/7/35	200	S4/32	2,2	LA7/30	CM125 - V125

IDROFIRE VTS P2E

DIMENSIONI DIMENSIONS

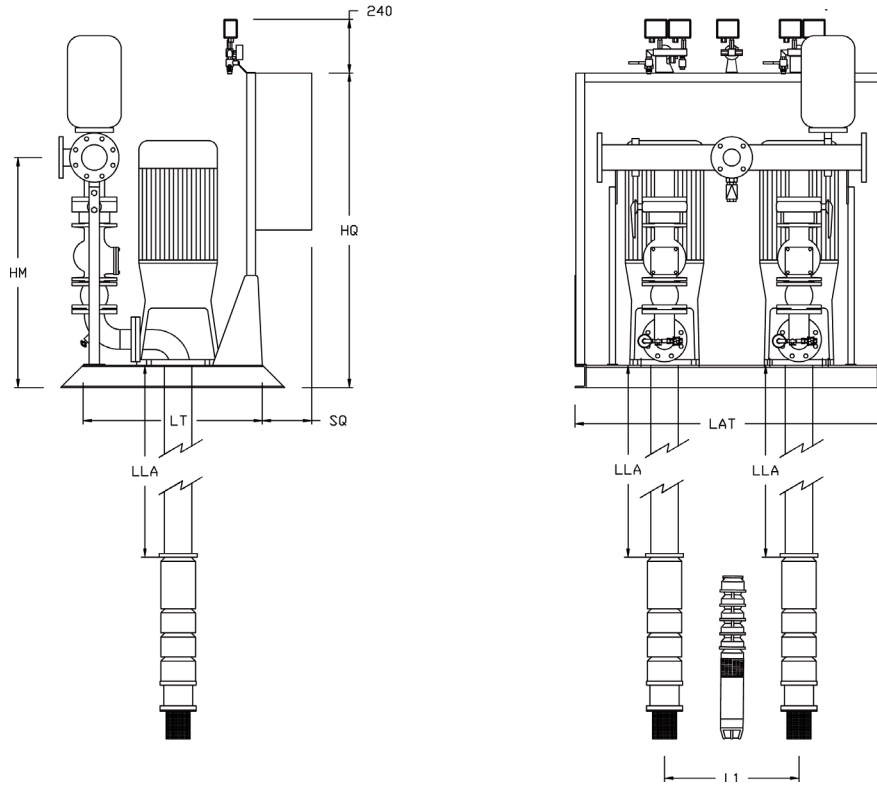

MODELLO GRUPPO	MANDATA kit valvole	collettore	PILOTA	HM	LAT	LT	LC	L1	HQ	SQ	LLA
MODEL GROUP	DELIVERY valves kit	manifold	JOCKEY PUMP	HM	LAT	LT	LC	L1	HQ	SQ	LLA
VTS P2E	DN	DN	DN AxM	mm	mm	mm	mm	mm	mm	mm	mm
EN VTS P2E 6G/4A EC+S4/11	50	80 - F50	1¼"	997	1100	800	1000	500	1400	230	3050
EN VTS P2E 6G/6A EC+S4/16	50	80 - F50	1¼"	997	1100	800	1000	500	1400	230	3050
EN VTS P2E 6G/8A EC+S4/21	50	80 - F50	1¼"	997	1100	800	1000	500	1400	230	3050
EN VTS P2E 6G/10A EC+S4/32	50	80 - F50	1¼"	997	1100	800	1000	500	1400	230	3050
EN VTS P2E 6G/12A EC+S4/32	50	80 - F50	1¼"	997	1100	800	1000	500	1400	230	3050
EN VTS P2E 6C/4A EC+S4/11	65	80 - F50	1¼"	1050	1100	800	1000	500	1400	230	3050
EN VTS P2E 6C/6A EC+S4/21	65	80 - F50	1¼"	1050	1100	800	1000	500	1400	230	3050
EN VTS P2E 6C/8A EC+S4/21	65	80 - F50	1¼"	1050	1100	900	1000	500	1400	230	3050
EN VTS P2E 6C/10A EC+S4/32	65	80 - F50	1¼"	1031	1100	900	1000	500	1400	230	3050
EN VTS P2E 7L/3A EC+S4/11	80	100 - F65	1¼"	1047	1100	800	1000	500	1400	230	3050
EN VTS P2E 7L/4A EC+S4/16	80	100 - F65	1¼"	1047	1100	800	1000	500	1400	230	3050
EN VTS P2E 7L/5A EC+S4/21	80	100 - F65	1¼"	1047	1100	800	1000	500	1400	230	3050
EN VTS P2E 7L/6A EC+S4/21	80	100 - F65	1¼"	1047	1100	900	1000	500	1400	230	3050
EN VTS P2E 7L/7A EC+S4/32	80	100 - F65	1¼"	1047	1100	1100	1000	500	1400	230	3050
EN VTS P2E 7L/8A EC+S4/32	80	100 - F65	1¼"	1047	1100	1100	1000	500	1400	230	3050
EN VTS P2E 7L/9A EC+S4/32	80	100 - F65	1¼"	1047	1100	1100	1000	500	1400	230	3050
EN VTS P2E 7C/2A EC+S4/11	80	100 - F65	1¼"	1047	1100	900	1000	500	1400	230	3050
EN VTS P2E 7C/3A EC+S4/11	80	100 - F65	1¼"	1047	1100	900	1000	500	1400	230	3050
EN VTS P2E 7C/4A EC+S4/16	80	100 - F65	1¼"	1047	1100	900	1000	500	1400	230	3050
EN VTS P2E 7C/5A EC+S4/21	80	100 - F65	1¼"	1047	1100	1100	1000	500	1400	230	3050
EN VTS P2E 7C/6A EC+S4/21	80	100 - F65	1¼"	1047	1100	1100	1000	500	1400	230	3050
EN VTS P2E 7C/7A EC+S4/32	80	100 - F65	1¼"	1047	1100	1100	1000	500	1400	230	3050
EN VTS P2E 8B/2A EC+S4/11	80	100 - F65	1¼"	1047	1100	800	1000	500	1400	230	3050
EN VTS P2E 8B/3A EC+S4/16	80	100 - F65	1¼"	1047	1400	800	1300	600	1400	230	3050
EN VTS P2E 8B/4A EC+S4/21	80	100 - F65	1¼"	1047	1400	900	1300	600	1400	230	3050
EN VTS P2E 8B/5A EC+S4/32	80	100 - F65	1¼"	1047	1400	1100	1300	600	1400	230	3050
EN VTS P2E 8B/6A EC+S4/32	80	100 - F65	1¼"	1047	1400	1100	1300	600	1400	230	3050

IDROFIRE VTS P2E

DIMENSIONI DIMENSIONS

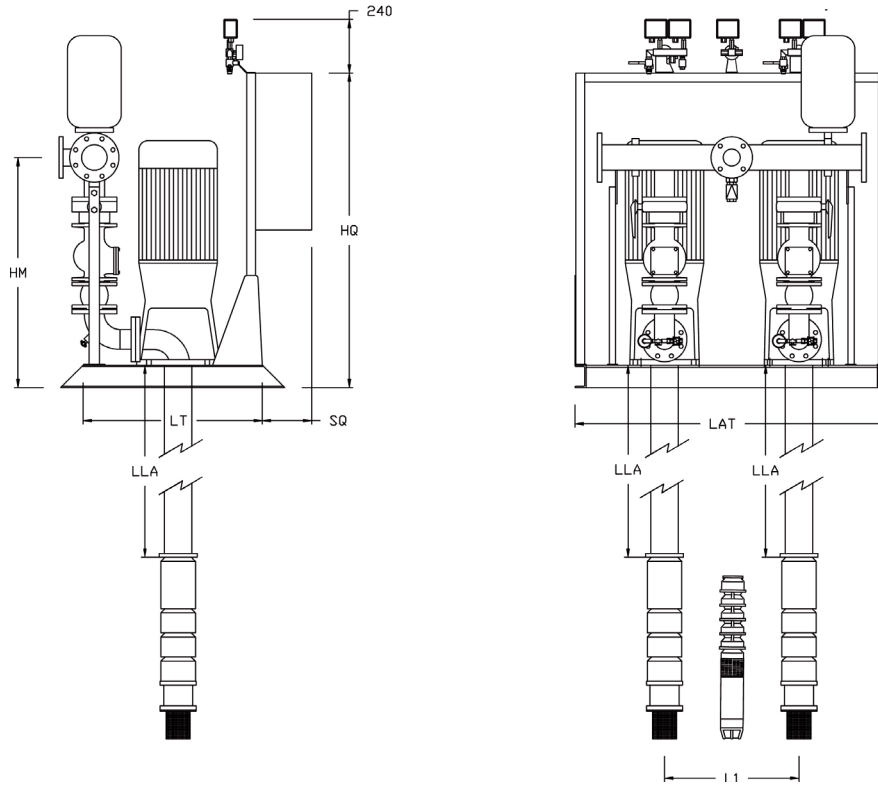

MODELLO GRUPPO	MANDATA kit valvole	collettore	PILOTA	HM	LAT	LT	LC	L1	HQ	SQ	LLA
MODEL GROUP	DELIVERY valves kit	manifold	JOCKEY PUMP	HM	LAT	LT	LC	L1	HQ	SQ	LLA
VTS P2E	DN	DN	DN AxM	mm	mm	mm	mm	mm	mm	mm	mm
EN VTS P2E 8F/2A EC+S4/11	80	100 - F65	1¼"	1047	1400	900	1300	600	1400	230	3050
EN VTS P2E 8F/3A EC+S4/16	80	100 - F65	1¼"	1047	1400	900	1300	600	1400	230	3050
EN VTS P2E 8F/4A EC+S4/21	80	100 - F65	1¼"	1047	1400	1100	1300	600	1400	230	3050
EN VTS P2E 8F/5A EC+S4/21	80	100 - F65	1¼"	1047	1400	1100	1300	600	1400	230	3050
EN VTS P2E 8F/6A EC+S4/32	80	100 - F65	1¼"	1047	1400	1100	1300	600	1400	230	3050
EN VTS P2E 8L/2A EC+S4/11	100	125 - F80	1¼"	1169	1400	900	1300	600	1400	230	3050
EN VTS P2E 8L/3A EC+S4/16	100	125 - F80	1¼"	1169	1400	900	1300	600	1400	230	3050
EN VTS P2E 8L/4A EC+S4/21	100	125 - F80	1¼"	1199	1400	1100	1300	600	1400	230	3050
EN VTS P2E 8L/5A EC+S4/21	100	125 - F80	1¼"	1199	1400	1100	1300	600	1400	230	3050
EN VTS P2E 8L/6A EC+S4/32	100	125 - F80	1¼"	1199	1400	1100	1300	600	1400	230	3050
EN VTS P2E 8C/2A EC+S4/11	100	125 - F80	1¼"	1169	1400	900	1300	600	1400	230	3050
EN VTS P2E 8C/3A EC+S4/16	100	125 - F80	1¼"	1199	1400	1100	1300	600	1400	230	3050
EN VTS P2E 8C/4A EC+S4/21	100	125 - F80	1¼"	1199	1400	1100	1300	600	1400	230	3050
EN VTS P2E 8C/5A EC+S4/32	100	125 - F80	1¼"	1189	1400	1300	1300	750	1400	230	3050
EN VTS P2E 8C/6A EC+S4/32	100	125 - F80	1¼"	1189	1400	1300	1300	750	1400	230	3050
EN VTS P2E 10F/1B EC+S4/11	150	200 - F125	1¼"	1464	1400	1100	1300	600	1400	230	3050
EN VTS P2E 10F/1A EC+S4/11	150	200 - F125	1¼"	1464	1400	1100	1300	600	1400	230	3050
EN VTS P2E 10F/2E EC+S4/11	150	200 - F125	1¼"	1464	1400	1100	1300	600	1400	230	3050
EN VTS P2E 10F/2CD EC+S4/16	150	200 - F125	1¼"	1454	1400	1300	1300	750	1400	230	3050
EN VTS P2E 10F/2BC EC+S4/16	150	200 - F125	1¼"	1454	1400	1300	1300	600	1400	330	3050
EN VTS P2E 10F/3CD EC+S4/21	150	200 - F125	1¼"	1454	1400	1300	1300	600	1400	330	3050
EN VTS P2E 10F/3B EC+S4/21	150	200 - F125	1¼"	1454	1600	1300	1500	750	1400	330	3050
EN VTS P2E 12B/1B EC+S4/11	150	200 - F125	1¼"	1464	1600	1100	1500	750	1400	230	3050
EN VTS P2E 12B/1A EC+S4/11	150	200 - F125	1¼"	1464	1600	1100	1500	750	1400	230	3050
EN VTS P2E 12B/2C EC+S4/21	150	200 - F125	1¼"	1454	1900	1300	1800	750	1400	330	3050
EN VTS P2E 12B/2B EC+S4/21	150	200 - F125	1¼"	1454	1900	1300	1800	750	1400	330	3050
EN VTS P2E 12B/3C EC+S4/32	150	200 - F125	1¼"	1454	1900	1300	1800	750	1400	330	3050

IDROFIRE VTS P1M

N.1 MOTOPOMPA DI SERVIZIO + PILOTA
NR.1 MAIN DIESEL MOTOR PUMP + JOCKEY PUMP



ELENCO COMPONENTI COMPONENT LIST

- | | |
|--|--|
| <ol style="list-style-type: none"> 1. Pompa di servizio del tipo verticale 2. Linea d'asse 3. Gruppo di comando con rinvio ad angolo per collegamento tra pompa e motore Diesel 4. Motore Diesel 5. Elettropompa pilota sommersa 6. Valvola di ritegno a clapet 7. Valvola di intercettazione lucchettabile 8. Valvola di ritegno 9. Valvola di intercettazione a sfera con leva 10. Collettore di mandata reversibile completo di flangia cieca 11. Derivazione per collettore di prova di portata 12. Predisposizione per kit sprinkler 13. Kit avviamento per pompe principali composto da 2 pressostati 2-14 bar con pulsante di prova integrato, 1 manometro 0-16 bar e circuito by-pass 14. Kit avviamento per pompa pilota composto da 1 pressostato con pulsante di prova integrato, 1 manometro 15. Quadri elettrici di comando (uno per ogni pompa) 16. Kit diaframma di ricircolo completo di indicatore visivo di flusso 17. Manometro 0-16 bar 18. Serbatoio Autoclave 24 lt PN16 19. Giunto di compensazione in gomma 20. Curva 90° biflangiata 21. Serbatoio gasolio per motore Diesel 22. Giunti antivibranti in gomma 23. Telaio | <ol style="list-style-type: none"> 1. Vertical service pump 2. Shaft line 3. Right angle drive unit to link the pump and the diesel engine 4. Motore Diesel engine 5. Submersible jockey pump 6. Swing Check Valve ("Clapet" Valve) 7. Shut-off valve lockable 8. Check valve 9. Ball valve with level 10. Reversible delivery manifold with blind flange 11. Shunt for flow meter 12. Predisposition for sprinkler kit 13. Starting kit for main pump composed by 2 pressure switch 2-14 bar with integrated test button, 1 pressure gauge 0-16 bar and by-pass circuit 14. Starting kit for jockey electric pump composed by 1 pressure switch with integrated test button, 1 pressure gauge 15. Electrical control panels (one for each pump) 16. Kit recycling diaphragm complete with visual flow indicator 17. Pressure gauge 0-16 bar 18. Diaphragm pressure vessel 24LT PN16 19. Rubber strain neutralizer 20. biflanged 90° curve 21. Fuel tank for diesel engine 22. Rubber anti-vibration joints 23. Frame |
|--|--|

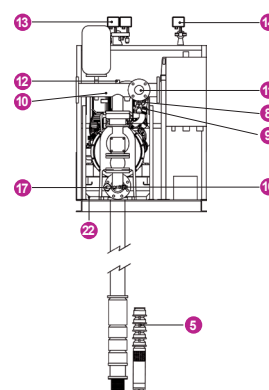
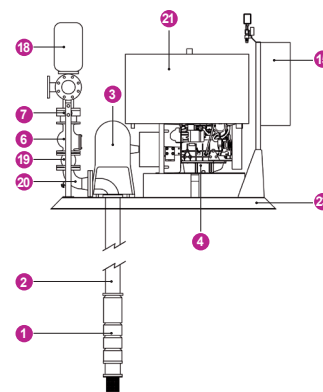

DROFIRE VTS P1M

DATI TECNICI TECHNICAL DATA

MODELLO GRUPPO	MOTOPOMPA					ELETTROPOMPA PILOTA		LINEA D'ASSE	KIT FLUSSIMETRO
	motore diesel			rinvio ad angolo		JOCKEY PUMP		LINESHAFT	FLOW METER KIT
MODEL GROUP	MOTOR PUMP			right angle drive unit					
	diesel engine								
VTS P1M	mod.	kW NA	kW NA	mod.	DN	mod.	kW	mod.	mod.
EN VTS P1M 6G/4A LC+S4/11	15LD440	6,2	6,7	R16/3L/20	80	S4/11	0,75	LA3/20	CM50 - V50
EN VTS P1M 6G/6A LC+S4/16	25LD425	10,4	11,5	R16/3L/20	80	S4/16	1,1	LA3/20	CM50 - V50
EN VTS P1M 6G/8A LC+S4/21	12LD477/2	13,6	15	R16/3L/20	80	S4/21	1,5	LA3/20	CM50 - V50
EN VTS P1M 6G/10A LC+S4/32	9LD625/2	17	18,9	R16/3L/20	80	S4/32	2,2	LA3/20	CM50 - V50
EN VTS P1M 6G/12A LC+S4/32	9LD625/2	17	18,9	R16/3L/20	80	S4/32	2,2	LA3/20	CM50 - V50
EN VTS P1M 6C/4A LC+S4/11	25LD425	10,4	11,5	R16/3L/20	80	S4/11	0,75	LA3/20	CM65 - V50
EN VTS P1M 6C/6A LC+S4/21	12LD477/2	13,6	15	R16/3L/20	80	S4/21	1,5	LA3/20	CM65 - V50
EN VTS P1M 6C/8A LC+S4/21	9LD625/2	17	18,9	R16/3L/20	80	S4/21	1,5	LA3/20	CM65 - V50
EN VTS P1M 6C/10A LC+S4/32	11LD626/3	24	26	R16/3L/24	80	S4/32	2,2	LA3/24	CM65 - V50
EN VTS P1M 7L/3A LC+S4/11	25LD425	10,4	11,5	R16/3L/20	80	S4/11	0,75	LA3/20	CM65 - V65
EN VTS P1M 7L/4A LC+S4/16	12LD477/2	13,6	15	R16/3L/20	80	S4/16	1,1	LA3/20	CM65 - V65
EN VTS P1M 7L/5A LC+S4/21	9LD625/2	17	18,9	R16/3L/20	80	S4/21	1,5	LA3/20	CM65 - V65
EN VTS P1M 7L/6A LC+S4/21	11LD626/3	24	26	R16/3L/20	80	S4/21	1,5	LA3/20	CM65 - V65
EN VTS P1M 7L/7A LC+S4/32	11LD626/3	24	26	R16/3L/24	80	S4/32	2,2	LA3/24	CM65 - V65
EN VTS P1M 7L/8A VC+S4/32	D703LE0	33	37	R16/3L/24	80	S4/32	2,2	LA3/24	CM65 - V65
EN VTS P1M 7L/9A VC+S4/32	D703LE0	33	37	R16/3L/24	80	S4/32	2,2	LA3/24	CM65 - V65
EN VTS P1M 7C/2A LC+S4/11	25LD425	10,4	11,5	R16/4L/20	100	S4/11	0,75	LA4/20	CM80 - V65
EN VTS P1M 7C/3A LC+S4/11	9LD625/2	17	18,9	R16/4L/20	100	S4/11	0,75	LA4/20	CM80 - V65
EN VTS P1M 7C/4A LC+S4/16	11LD626/3	24	26	R16/4L/20	100	S4/16	1,1	LA4/20	CM80 - V65
EN VTS P1M 7C/5A VC+S4/21	D703LE0	33	37	R26/4L/24	100	S4/21	1,5	LA4/24	CM80 - V65
EN VTS P1M 7C/6A VC+S4/21	D703LE0	33	37	R26/4L/24	100	S4/21	1,5	LA4/24	CM80 - V65
EN VTS P1M 7C/7A VC+S4/32	D703LTE0	48	53	R26/4L/24	100	S4/32	2,2	LA4/24	CM80 - V65
EN VTS P1M 8B/2A LC+S4/11	25LD425	10,4	11,5	R16/3L/20	80	S4/11	0,75	LA3/20	CM65 - V65
EN VTS P1M 8B/3A LC+S4/16	9LD625/2	17	18,9	R16/3L/20	80	S4/16	1,1	LA3/20	CM65 - V65
EN VTS P1M 8B/4A LC+S4/21	11LD626/3	24	26	R16/3L/20	80	S4/21	1,5	LA3/20	CM65 - V65
EN VTS P1M 8B/5A VC+S4/32	D703LE0	33	37	R26/3L/24	80	S4/32	2,2	LA3/24	CM65 - V65
EN VTS P1M 8B/6A VC+S4/32	D703LE0	33	37	R26/3L/24	80	S4/32	2,2	LA3/24	CM65 - V65
EN VTS P1M 8F/2A LC+S4/11	12LD477/2	13,6	15	R16/4L/20	100	S4/11	0,75	LA4/20	CM80 - V65
EN VTS P1M 8F/3A LC+S4/16	9LD625/2	17	18,9	R16/4L/20	100	S4/16	1,1	LA4/20	CM80 - V65
EN VTS P1M 8F/4A LC+S4/21	11LD626/3	24	26	R26/4L/24	100	S4/21	1,5	LA4/24	CM80 - V65
EN VTS P1M 8F/5A VC+S4/21	D703LE0	33	37	R26/4L/24	100	S4/21	1,5	LA4/24	CM80 - V65
EN VTS P1M 8F/6A VC+S4/32	D703LTE0	48	53	R26/4L/24	100	S4/32	2,2	LA4/24	CM80 - V65
EN VTS P1M 8L/2A LC+S4/11	12LD477/2	13,6	15	R16/5/20	125	S4/11	0,75	LA5/20	CM80 - V80
EN VTS P1M 8L/3A LC+S4/16	11LD626/3	24	26	R16/5/20	125	S4/16	1,1	LA5/20	CM80 - V80
EN VTS P1M 8L/4A VC+S4/21	D703LE0	33	37	R26/5/24	125	S4/21	1,5	LA5/24	CM80 - V80
EN VTS P1M 8L/5A VC+S4/21	D703LE0	33	37	R26/5/24	125	S4/21	1,5	LA5/24	CM80 - V80
EN VTS P1M 8L/6A VC+S4/32	D703LTE0	48	53	R26/5/24	125	S4/32	2,2	LA5/24	CM80 - V80
EN VTS P1M 8C/2A LC+S4/11	9LD625/2	17	18,9	R16/5/20	125	S4/11	0,75	LA5/20	CM100 - V80
EN VTS P1M 8C/3A VC+S4/16	D703LE0	33	37	R26/5/24	125	S4/16	1,1	LA5/24	CM100 - V80
EN VTS P1M 8C/4A VC+S4/21	D703LTE0	48	53	R26/5/24	125	S4/21	1,5	LA5/24	CM100 - V80
EN VTS P1M 8C/5A VC+S4/32	D703LTE0	48	53	R42/5/30	125	S4/32	2,2	LA5/30	CM100 - V80
EN VTS P1M 8C/6A VC+S4/32	D754TPE2	65	73	R42/5/30	125	S4/32	2,2	LA5/30	CM100 - V80
EN VTS P1M 10F/1B VC+S4/11	D703LE0	33	37	R26/6/24	125	S4/11	0,75	LA6/24	CM150 - V125
EN VTS P1M 10F/1A VC+S4/11	D703LTE0	48	53	R26/6/30	150	S4/11	0,75	LA6/30	CM150 - V125
EN VTS P1M 10F/2E VC+S4/11	D703LTE0	48	53	R42/6/30	150	S4/11	0,75	LA6/30	CM150 - V125
EN VTS P1M 10F/2CD VC+S4/16	D754TPE2	65	73	R42/6/30	150	S4/16	1,1	LA6/30	CM150 - V125
EN VTS P1M 10F/2BC VC+S4/16	D754TPE2	65	73	R42/6/30	150	S4/16	1,1	LA6/30	CM150 - V125
EN VTS P1M 10F/3CD VC+S4/21	D756IPE2	100	110	R75/6/30	150	S4/21	1,5	LA6/30	CM150 - V125
EN VTS P1M 10F/3B VC+S4/21	D756IPE2	100	110	R75/6/30	150	S4/21	1,5	LA6/30	CM150 - V125
EN VTS P1M 12B/1B VC+S4/11	D703LTE0	48	53	R26/7/30	175	S4/11	0,75	LA7/30	CM125 - V125
EN VTS P1M 12B/1A VC+S4/11	D703LTE0	48	53	R42/7/30	175	S4/11	0,75	LA7/30	CM125 - V125
EN VTS P1M 12B/2C VC+S4/21	D754TPE2	65	73	R75/7/30	175	S4/21	1,5	LA7/30	CM125 - V125
EN VTS P1M 12B/2B VC+S4/21	D756IPE2	100	110	R75/7/30	175	S4/21	1,5	LA7/30	CM125 - V125
EN VTS P1M 12B/3C VC+S4/32	D756IPE2	100	110	R75/7/30	175	S4/32	2,2	LA7/30	CM125 - V125

IDROFIRE VTS P1M

DIMENSIONI DIMENSIONS

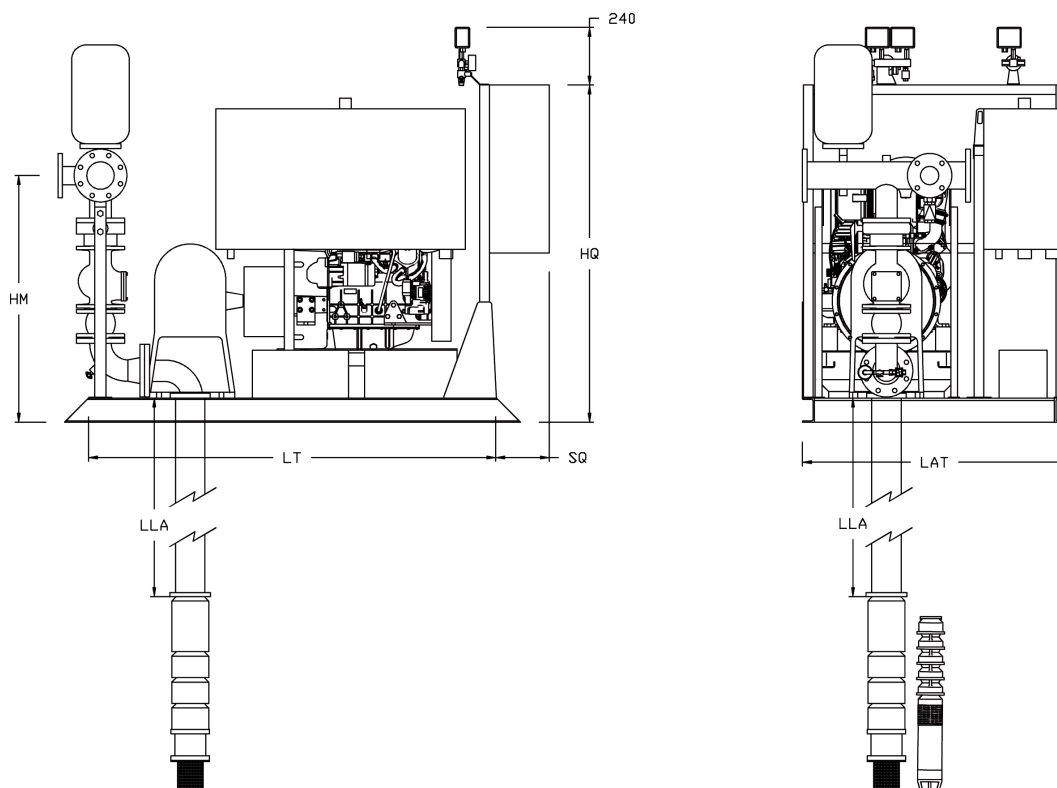

MODELLO GRUPPO	MANDATA kit valvole	collettore	PILOTA	HM	LAT	LT	LC	HQ	SQ	LLA
MODEL GROUP	DELIVERY valves kit	manifold	JOCKEY PUMP	HM	LAT	LT	LC	HQ	SQ	LLA
VTS P1M	DN	DN	DN AxM	mm	mm	mm	mm	mm	mm	mm
EN VTS P1M 6G/4A LC+S4/11	50	80 - F50	1¼"	997	1000	1400	700	1400	230	3050
EN VTS P1M 6G/6A LC+S4/16	50	80 - F50	1¼"	997	1000	1400	700	1401	230	3050
EN VTS P1M 6G/8A LC+S4/21	50	80 - F50	1¼"	997	1000	1600	700	1402	230	3050
EN VTS P1M 6G/10A LC+S4/32	50	80 - F50	1¼"	997	1200	1600	900	1403	230	3050
EN VTS P1M 6G/12A LC+S4/32	50	80 - F50	1¼"	997	1200	1600	900	1404	230	3050
EN VTS P1M 6C/4A LC+S4/11	65	80 - F50	1¼"	1050	1000	1400	700	1405	230	3050
EN VTS P1M 6C/6A LC+S4/21	65	80 - F50	1¼"	1050	1000	1600	700	1406	230	3050
EN VTS P1M 6C/8A LC+S4/21	65	80 - F50	1¼"	1050	1200	1600	900	1407	230	3050
EN VTS P1M 6C/10A LC+S4/32	65	80 - F50	1¼"	1050	1400	1800	1100	1408	230	3050
EN VTS P1M 7L/3A LC+S4/11	80	100 - F65	1¼"	1047	1000	1400	700	1409	230	3050
EN VTS P1M 7L/4A LC+S4/16	80	100 - F65	1¼"	1047	1000	1600	700	1410	230	3050
EN VTS P1M 7L/5A LC+S4/21	80	100 - F65	1¼"	1047	1200	1600	900	1411	230	3050
EN VTS P1M 7L/6A LC+S4/21	80	100 - F65	1¼"	1047	1400	1800	1100	1412	230	3050
EN VTS P1M 7L/7A LC+S4/32	80	100 - F65	1¼"	1047	1400	1800	1100	1413	230	3050
EN VTS P1M 7L/8A VC+S4/32	80	100 - F65	1¼"	1047	1000	1800	700	1414	230	3050
EN VTS P1M 7L/9A VC+S4/32	80	100 - F65	1¼"	1047	1000	1800	700	1415	230	3050
EN VTS P1M 7C/2A LC+S4/11	80	100 - F65	1¼"	1047	1000	1400	700	1416	230	3050
EN VTS P1M 7C/3A LC+S4/11	80	100 - F65	1¼"	1047	1200	1600	900	1417	230	3050
EN VTS P1M 7C/4A LC+S4/16	80	100 - F65	1¼"	1047	1400	1800	1100	1418	230	3050
EN VTS P1M 7C/5A VC+S4/21	80	100 - F65	1¼"	1047	1000	1800	700	1419	230	3050
EN VTS P1M 7C/6A VC+S4/21	80	100 - F65	1¼"	1047	1000	1800	700	1420	230	3050
EN VTS P1M 7C/7A VC+S4/32	80	100 - F65	1¼"	1047	1000	1800	700	1421	230	3050
EN VTS P1M 8B/2A LC+S4/11	80	100 - F65	1¼"	1047	1000	1400	700	1422	230	3050
EN VTS P1M 8B/3A LC+S4/16	80	100 - F65	1¼"	1047	1200	1600	900	1423	230	3050
EN VTS P1M 8B/4A LC+S4/21	80	100 - F65	1¼"	1047	1400	1800	1100	1424	230	3050
EN VTS P1M 8B/5A VC+S4/32	80	100 - F65	1¼"	1047	1000	1800	700	1425	230	3050
EN VTS P1M 8B/6A VC+S4/32	80	100 - F65	1¼"	1047	1000	1800	700	1426	230	3050

IDROFIRE VTS P1M

DIMENSIONI DIMENSIONS

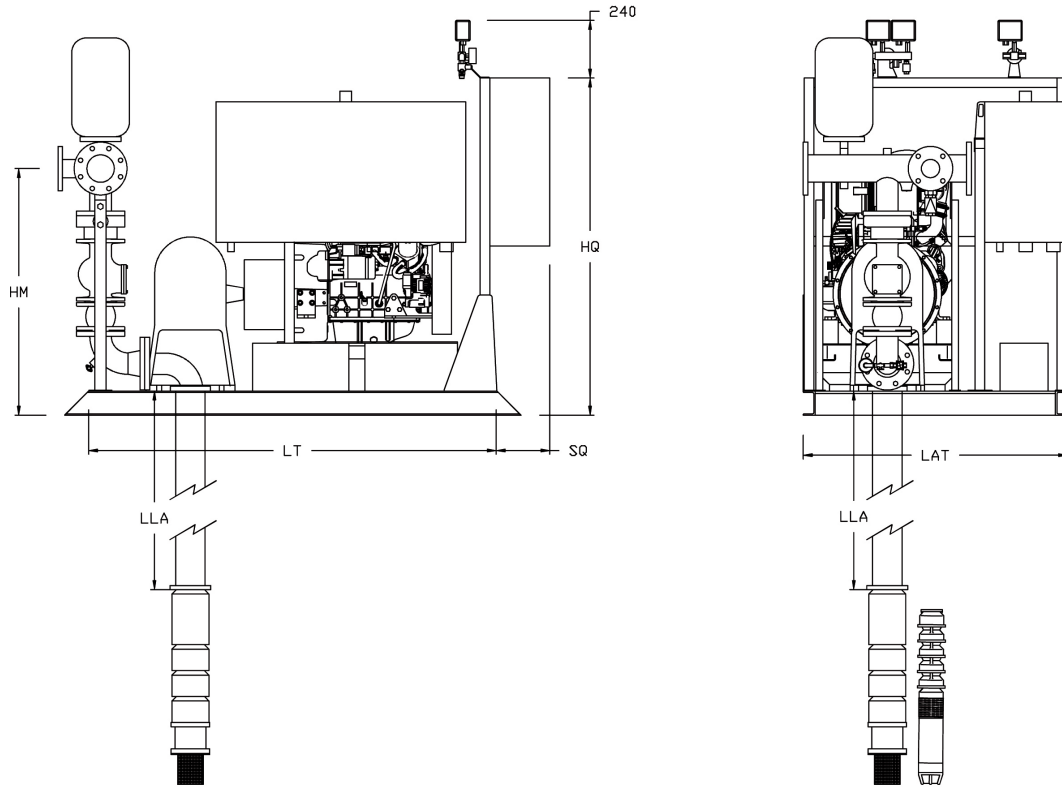

MODELLO GRUPPO	MANDATA kit valvole	collettore	PILOTA	HM	LAT	LT	LC	HQ	SQ	LLA
MODEL GROUP	DELIVERY valves kit	manifold	JOCKEY PUMP	HM	LAT	LT	LC	HQ	SQ	LLA
VTS P1M	DN	DN	DN AxM	mm	mm	mm	mm	mm	mm	mm
EN VTS P1M 8F/2A LC+S4/11	80	100 - F65	1¼"	1047	1000	1600	700	1427	230	3050
EN VTS P1M 8F/3A LC+S4/16	80	100 - F65	1¼"	1047	1200	1600	900	1428	230	3050
EN VTS P1M 8F/4A LC+S4/21	80	100 - F65	1¼"	1047	1400	1800	1100	1429	230	3050
EN VTS P1M 8F/5A VC+S4/21	80	100 - F65	1¼"	1047	1000	1800	700	1430	230	3050
EN VTS P1M 8F/6A VC+S4/32	80	100 - F65	1¼"	1047	1000	1800	700	1431	230	3050
EN VTS P1M 8L/2A LC+S4/11	100	125 - F80	1¼"	1169	1000	1600	700	1432	230	3050
EN VTS P1M 8L/3A LC+S4/16	100	125 - F80	1¼"	1169	1400	1800	1100	1433	230	3050
EN VTS P1M 8L/4A VC+S4/21	100	125 - F80	1¼"	1169	1000	2000	700	1434	230	3050
EN VTS P1M 8L/5A VC+S4/21	100	125 - F80	1¼"	1169	1000	2000	700	1435	230	3050
EN VTS P1M 8L/6A VC+S4/32	100	125 - F80	1¼"	1169	1000	2000	700	1436	230	3050
EN VTS P1M 8C/2A LC+S4/11	100	125 - F80	1¼"	1169	1200	1600	900	1437	230	3050
EN VTS P1M 8C/3A VC+S4/16	100	125 - F80	1¼"	1169	1000	2000	700	1438	230	3050
EN VTS P1M 8C/4A VC+S4/21	100	125 - F80	1¼"	1169	1000	2000	700	1439	230	3050
EN VTS P1M 8C/5A VC+S4/32	100	125 - F80	1¼"	1199	1000	2000	700	1440	230	3050
EN VTS P1M 8C/6A VC+S4/32	100	125 - F80	1¼"	1199	1000	2300	700	1441	230	3050
EN VTS P1M 10F/1B VC+S4/11	150	200 - F125	1¼"	1434	1000	2000	700	1442	230	3050
EN VTS P1M 10F/1A VC+S4/11	150	200 - F125	1¼"	1464	1000	2000	700	1443	230	3050
EN VTS P1M 10F/2E VC+S4/11	150	200 - F125	1¼"	1464	1000	2000	700	1444	230	3050
EN VTS P1M 10F/2CD VC+S4/16	150	200 - F125	1¼"	1464	1000	2300	700	1445	230	3050
EN VTS P1M 10F/2BC VC+S4/16	150	200 - F125	1¼"	1464	1000	2300	700	1446	230	3050
EN VTS P1M 10F/3CD VC+S4/21	150	200 - F125	1¼"	1464	1000	2500	700	1447	230	3050
EN VTS P1M 10F/3B VC+S4/21	150	200 - F125	1¼"	1464	1000	2500	700	1448	230	3050
EN VTS P1M 12B/1B VC+S4/11	150	200 - F125	1¼"	1464	1000	2000	700	1449	230	3050
EN VTS P1M 12B/1A VC+S4/11	150	200 - F125	1¼"	1464	1000	2000	700	1450	230	3050
EN VTS P1M 12B/2C VC+S4/21	150	200 - F125	1¼"	1464	1000	2300	700	1451	230	3050
EN VTS P1M 12B/2B VC+S4/21	150	200 - F125	1¼"	1464	1000	2500	700	1452	230	3050
EN VTS P1M 12B/3C VC+S4/32	150	200 - F125	1¼"	1464	1000	2500	700	1453	230	3050

IDROFIRE VTS PEM

N.1 ELETTOPOMPA DI SERVIZIO + N.1 MOTOPOMPA DI RISERVA + PILOTA
 NR.1 MAIN ELECTRIC PUMP + NR.1 BACKUP DIESEL MOTOR PUMP + JOCKEY PUMP

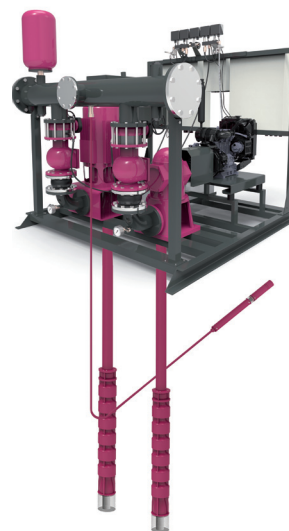
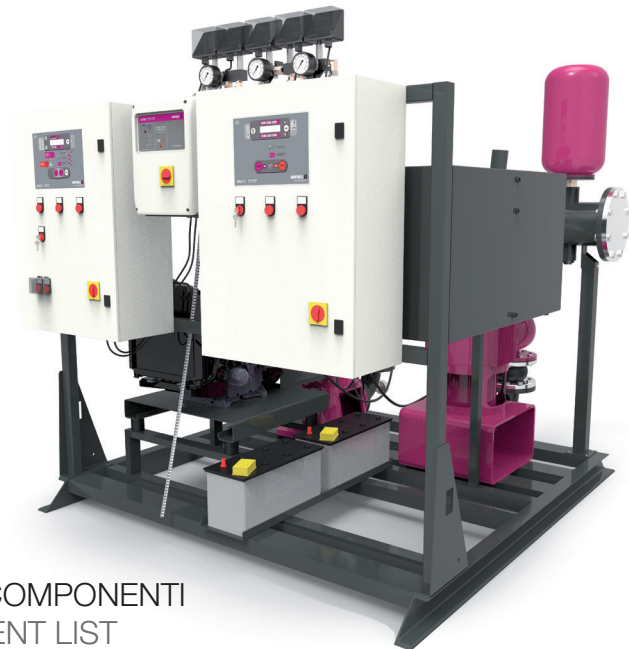

ELENCO COMPONENTI COMPONENT LIST

- | | |
|---|---|
| <ol style="list-style-type: none"> 1. Pompa di servizio del tipo verticale 1A. Pompa di riserva del tipo verticale 2. Linea d'asse per pompa di servizio e pompa di riserva 3. Gruppo di comando con rinvio ad angolo per collegamento tra pompa (di servizio) e motore Diesel 4. Motore elettrico per pompa di servizio e di riserva 5. Gruppo di comando con rinvio ad angolo per collegamento tra pompa (di riserva) e motore Diesel 6. Motore Diesel 7. Elettropompa pilota sommersa 8. Valvola di ritegno a clapet 9. Valvola di intercettazione lucchettabile 10. Valvola di ritegno 11. Valvola di intercettazione a sfera con leva 12. Collettore di mandata reversibile completo di flangia cieca 13. Derivazione per collettore di prova di portata 14. Predisposizione per kit sprinkler 15. Kit avviamento per pompe principali composto da 2 pressostati 2-14 bar con pulsante di prova integrato, 1 manometro 0-16 bar e circuito by-pass 16. Kit avviamento per pompa pilota composto da 1 pressostato con pulsante di prova integrato, 1 manometro 17. Quadri elettrici di comando (uno per ogni pompa) 18. Kit diaframma di ricircolo completo di indicatore visivo di flusso 19. Manometro 0-16 bar 20. Serbatoio Autoclave 24 lt PN16 21. Giunto di compensazione in gomma 22. Curva 90° biflangiata 23. Serbatoio gasolio per motore Diesel 24. Giunti antivibranti in gomma 25. Telaio | <ol style="list-style-type: none"> 1. Service vertical pump 1A. Backup vertical pump 2. Shaft line for service and backup pump 3. Drive unit to link the pump (service) and electrical \ engine 4. Electrical engine for service pump and backup pump 5. Right angle drive unit to link the pump (backup) and the diesel engine 6. Diesel engine 7. Submersible jockey pump 8. Swing Check Valve ("Clapet" Valve) 9. Shut-off valve lockable 10. Check valve 11. Ball valve with level 12. Reversible delivery manifold with blind flange 13. Shunt for flow meter 14. Predisposition for sprinkler kit 15. Starting kit for main pump composed by 2 pressure switch 2-14 bar with integrated test button, 1 pressure gauge 0-16 bar and by-pass circuit 16. Starting kit for jockey electric pump composed by 1 pressure switch with integrated test button, 1 pressure gauge 17. Electrical control panels (one for each pump) 18. Kit recycling diaphragm complete with visual flow indicator 19. Pressure gauge 0-16 bar 20. Diaphragm pressure vessel 24LT PN16 21. Rubber strain neutralizer 22. Biflanged 90° curve 23. Fuel tank for diesel engine 24. Rubber anti-vibration joints 25. Frame |
|---|---|

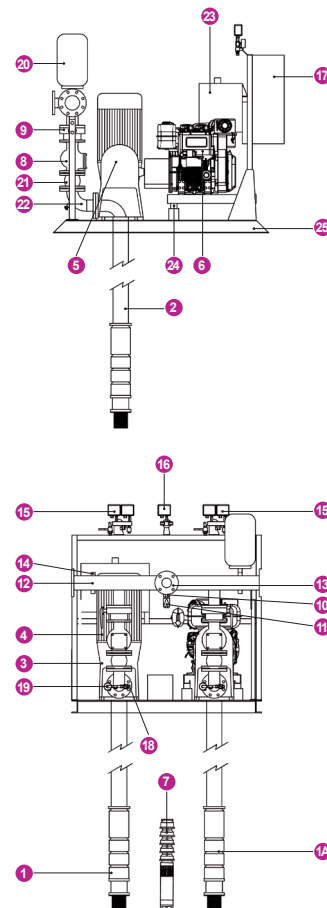

DROFIRE VTS PEM

DATI TECNICI TECHNICAL DATA

MODELLO GRUPPO	ELETTROPOMPA			MOTOPOMPA				ELETTROPOMPA PILOTA		LINEA D'ASSE	KIT FLUSSIMETRO	
	mot. elett.	gruppo di comando		mot. diesel		rinvio ad angolo		JOCKEY PUMP		LINESHAFT	FLOW METER KIT	
	el. engine	drive unit on the surface		diesel engine		right angle drive unit						
VTS PEM	kW	mod.	DN	mod.	kW NA	kW NB	mod.	DN	mod.	kW	mod.	mod.
EN VTS PEM 6G/4A ELC+S4/11	7,5	E13/38/3L/20A	80	15LD440	6,2	6,7	R16/3L/20	80	S4/11	0,75	LA3/20	CM50 - V50
EN VTS PEM 6G/6A ELC+S4/16	11	E18/42/3L/20A	80	25LD425	10,4	11,5	R16/3L/20	80	S4/16	1,1	LA3/20	CM50 - V50
EN VTS PEM 6G/8A ELC+S4/21	11	E18/42/3L/20A	80	12LD477/2	13,6	15	R16/3L/20	80	S4/21	1,5	LA3/20	CM50 - V50
EN VTS PEM 6G/10A ELC+S4/32	15	E18/42/3L/20A	80	9LD625/2	17	18,9	R16/3L/20	80	S4/32	2,2	LA3/20	CM50 - V50
EN VTS PEM 6G/12A ELC+S4/32	18,5	E18/42/3L/20A	80	9LD625/2	17	18,9	R16/3L/20	80	S4/32	2,2	LA3/20	CM50 - V50
EN VTS PEM 6C/4A ELC+S4/11	11	E18/42/3L/20A	80	25LD425	10,4	11,5	R16/3L/20	80	S4/11	0,75	LA3/20	CM65 - V50
EN VTS PEM 6C/6A ELC+S4/21	15	E18/42/3L/20A	80	12LD477/2	13,6	15	R16/3L/20	80	S4/21	1,5	LA3/20	CM65 - V50
EN VTS PEM 6C/8A ELC+S4/21	18,5	E18/48/3L/20A	80	9LD625/2	17	18,9	R16/3L/20	80	S4/21	1,5	LA3/20	CM65 - V50
EN VTS PEM 6C/10A ELC+S4/32	30	E20/55/3/24	100	11LD626/3	24	26	R16/3L/24	80	S4/32	2,2	LA3/24	CM65 - V50
EN VTS PEM 7L/3A ELC+S4/11	11	E18/42/3L/20A	80	25LD425	10,4	11,5	R16/3L/20	80	S4/11	0,75	LA3/20	CM65 - V65
EN VTS PEM 7L/4A ELC+S4/16	15	E18/42/3L/20A	80	12LD477/2	13,6	15	R16/3L/20	80	S4/16	1,1	LA3/20	CM65 - V65
EN VTS PEM 7L/5A ELC+S4/21	18,5	E18/42/3L/20A	80	9LD625/2	17	18,9	R16/3L/20	80	S4/21	1,5	LA3/20	CM65 - V65
EN VTS PEM 7L/6A ELC+S4/21	22	E18/48/3L/20A	80	11LD626/3	24	26	R16/3L/20	80	S4/21	1,5	LA3/20	CM65 - V65
EN VTS PEM 7L/7A ELC+S4/32	30	E20/55/3/24	100	11LD626/3	24	26	R16/3L/24	80	S4/32	2,2	LA3/24	CM65 - V65
EN VTS PEM 7L/8A EVC+S4/32	30	E20/55/3/24	100	D703LE0	33	37	R16/3L/24	80	S4/32	2,2	LA3/24	CM65 - V65
EN VTS PEM 7L/9A EVC+S4/32	30	E20/55/3/24	100	D703LE0	33	37	R16/3L/24	80	S4/32	2,2	LA3/24	CM65 - V65
EN VTS PEM 7C/2A ELC+S4/11	11	E18/42/4L/20A	100	25LD425	10,4	11,5	R16/4L/20	100	S4/11	0,75	LA4/20	CM80 - V65
EN VTS PEM 7C/3A ELC+S4/11	18,5	E18/42/4L/20A	100	9LD625/2	17	18,9	R16/4L/20	100	S4/11	0,75	LA4/20	CM80 - V65
EN VTS PEM 7C/4A ELC+S4/16	22	E18/48/4L/20A	100	11LD626/3	24	26	R16/4L/20	100	S4/16	1,1	LA4/20	CM80 - V65
EN VTS PEM 7C/5A EVC+S4/21	30	E20/55/4/24	100	D703LE0	33	37	R26/4L/24	100	S4/21	1,5	LA4/24	CM80 - V65
EN VTS PEM 7C/6A EVC+S4/21	37	E20/55/4/24	100	D703LE0	33	37	R26/4L/24	100	S4/21	1,5	LA4/24	CM80 - V65
EN VTS PEM 7C/7A EVC+S4/32	37	E22/55/4/24	100	D703LTE0	48	53	R26/4L/24	100	S4/32	2,2	LA4/24	CM80 - V65
EN VTS PEM 8B/2A ELC+S4/11	11	E18/42/3L/20A	80	25LD425	10,4	11,5	R16/3L/20	80	S4/11	0,75	LA3/20	CM65 - V65
EN VTS PEM 8B/3A ELC+S4/16	18,5	E18/42/3L/20A	80	9LD625/2	17	18,9	R16/3L/20	80	S4/16	1,1	LA3/20	CM65 - V65
EN VTS PEM 8B/4A ELC+S4/21	22	E18/48/3L/20A	80	11LD626/3	24	26	R16/3L/20	80	S4/21	1,5	LA3/20	CM65 - V65
EN VTS PEM 8B/5A EVC+S4/32	30	E20/55/3/24	100	D703LE0	33	37	R26/3L/24	80	S4/32	2,2	LA3/24	CM65 - V65
EN VTS PEM 8B/6A EVC+S4/32	37	E20/55/3/24	100	D703LE0	33	37	R26/3L/24	80	S4/32	2,2	LA3/24	CM65 - V65
EN VTS PEM 8F/2A ELC+S4/11	15	E18/42/4L/20A	100	12LD477/2	13,6	15	R16/4L/20	100	S4/11	0,75	LA4/20	CM80 - V65
EN VTS PEM 8F/3A ELC+S4/16	18,5	E18/42/4L/20A	100	9LD625/2	17	18,9	R16/4L/20	100	S4/16	1,1	LA4/20	CM80 - V65
EN VTS PEM 8F/4A ELC+S4/21	30	E20/55/4/24	100	11LD626/3	24	26	R26/4L/24	100	S4/21	1,5	LA4/24	CM80 - V65
EN VTS PEM 8F/5A EVC+S4/21	30	E20/55/4/24	100	D703LE0	33	37	R26/4L/24	100	S4/21	1,5	LA4/24	CM80 - V65
EN VTS PEM 8F/6A EVC+S4/32	37	E20/55/4/24	100	D703LTE0	48	53	R26/4L/24	100	S4/32	2,2	LA4/24	CM80 - V65
EN VTS PEM 8L/2A ELC+S4/11	15	E18/42/5/20A	125	12LD477/2	13,6	15	R16/5/20	125	S4/11	0,75	LA5/20	CM80 - V80
EN VTS PEM 8L/3A ELC+S4/16	22	E18/48/5/20A	125	11LD626/3	24	26	R16/5/20	125	S4/16	1,1	LA5/20	CM80 - V80
EN VTS PEM 8L/4A EVC+S4/21	30	E20/55/5/24	125	D703LE0	33	37	R26/5/24	125	S4/21	1,5	LA5/24	CM80 - V80
EN VTS PEM 8L/5A EVC+S4/21	37	E20/55/5/24	125	D703LE0	33	37	R26/5/24	125	S4/21	1,5	LA5/24	CM80 - V80
EN VTS PEM 8L/6A EVC+S4/32	45	E22/55/5/30	125	D703LTE0	48	53	R26/5/24	125	S4/32	2,2	LA5/24	CM80 - V80
EN VTS PEM 8C/2A ELC+S4/11	18,5	E18/42/5/20A	125	9LD625/2	17	18,9	R16/5/20	125	S4/11	0,75	LA5/20	CM100 - V80
EN VTS PEM 8C/3A EVC+S4/16	30	E20/55/5/24	125	D703LE0	33	37	R26/5/24	125	S4/16	1,1	LA5/24	CM100 - V80
EN VTS PEM 8C/4A EVC+S4/21	37	E22/55/5/30	125	D703LTE0	48	53	R26/5/24	125	S4/21	1,5	LA5/24	CM100 - V80
EN VTS PEM 8C/5A EVC+S4/32	45	E28/60/5/30	150	D703LTE0	48	53	R42/5/30	125	S4/32	2,2	LA5/30	CM100 - V80
EN VTS PEM 8C/6A EVC+S4/32	55	E28/60/5/30	150	D754TPE2	65	73	R42/5/30	125	S4/32	2,2	LA5/30	CM100 - V80
EN VTS PEM 10F/1B EVC+S4/11	37	E20/55/6/24	150	D703LE0	33	37	R26/6/24	125	S4/11	0,75	LA6/24	CM150 - V125
EN VTS PEM 10F/1A EVC+S4/11	45	E22/55/6/30	150	D703LTE0	48	53	R26/6/30	150	S4/11	0,75	LA6/30	CM150 - V125
EN VTS PEM 10F/2E EVC+S4/11	45	E22/55/6/30	150	D703LTE0	48	53	R42/6/30	150	S4/11	0,75	LA6/30	CM150 - V125
EN VTS PEM 10F/2CD EVC+S4/16	55	E28/60/6/30	150	D754TPE2	65	73	R42/6/30	150	S4/16	1,1	LA6/30	CM150 - V125
EN VTS PEM 10F/2BC EVC+S4/16	75	E28/65A/6/30	150	D754TPE2	65	73	R42/6/30	150	S4/16	1,1	LA6/30	CM150 - V125
EN VTS PEM 10F/3CD EVC+S4/21	90	E28/65A/6/30	150	D756IPE2	100	110	R75/6/30	150	S4/21	1,5	LA6/30	CM150 - V125
EN VTS PEM 10F/3B EVC+S4/21	110	E28/65A/6/30	150	D756IPE2	100	110	R75/6/30	150	S4/21	1,5	LA6/30	CM150 - V125
EN VTS PEM 12B/1B EVC+S4/11	37	E20/55/7/30	175	D703LTE0	48	53	R26/7/30	175	S4/11	0,75	LA7/30	CM125 - V125
EN VTS PEM 12B/1A EVC+S4/11	45	E22/55/7/30	175	D703LTE0	48	53	R42/7/30	175	S4/11	0,75	LA7/30	CM125 - V125
EN VTS PEM 12B/2C EVC+S4/21	75	E28/65A/7/30	200	D754TPE2	65	73	R75/7/30	175	S4/21	1,5	LA7/30	CM125 - V125
EN VTS PEM 12B/2B EVC+S4/21	75	E28/65A/7/30	200	D756IPE2	100	110	R75/7/30	175	S4/21	1,5	LA7/30	CM125 - V125
EN VTS PEM 12B/3C EVC+S4/32	110	E28/65A/7/35	200	D756IPE2	100	110	R75/7/30	175	S4/32	2,2	LA7/30	CM125 - V125

IDROFIRE VTS PEM

DIMENSIONI DIMENSIONS

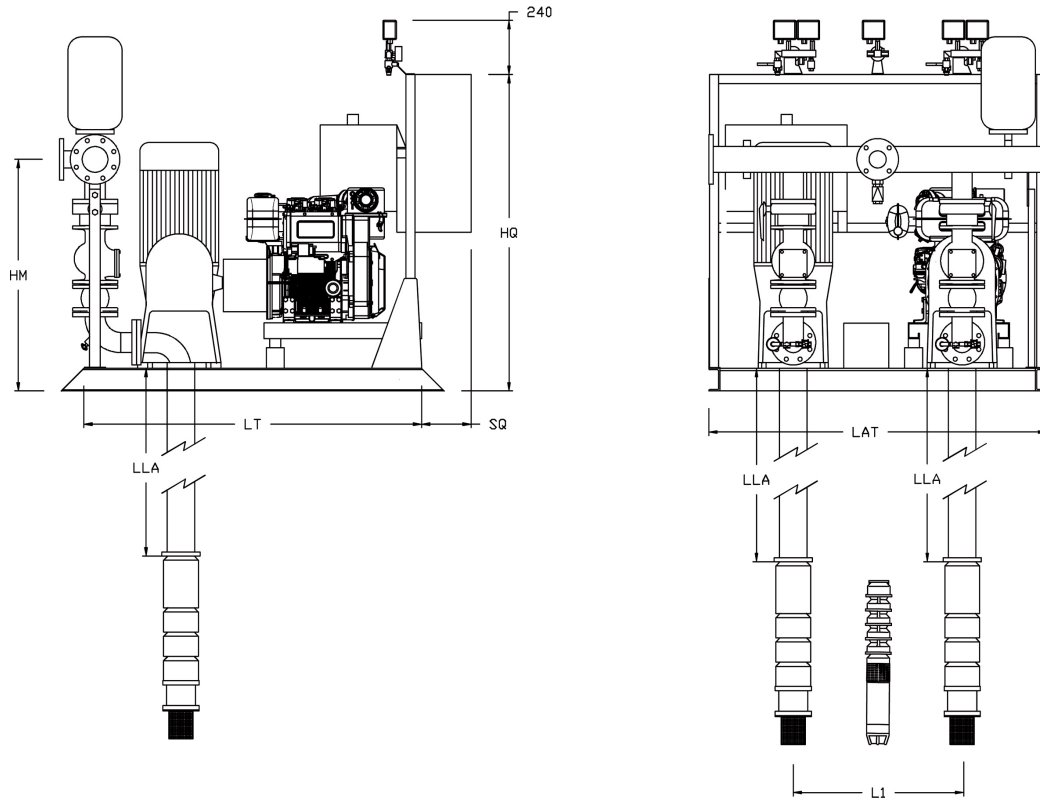

MODELLO GRUPPO	MANDATA kit valvole DELIVERY valves kit	collettore manifold	PILOTA JOCKEY PUMP	HM	LAT	LT	LC	L1	HQ	SQ	LLA
MODEL GROUP	DN	DN	DN AxM	mm	mm	mm	mm	mm	mm	mm	mm
EN VTS PEM 6G/4A ELC+S4/11	50	80 - F50	1¼"	997	1400	1400	1300	600	1400	230	3050
EN VTS PEM 6G/6A ELC+S4/16	50	80 - F50	1¼"	997	1400	1400	1300	600	1401	230	3050
EN VTS PEM 6G/8A ELC+S4/21	50	80 - F50	1¼"	997	1400	1600	1500	600	1402	230	3050
EN VTS PEM 6G/10A ELC+S4/32	50	80 - F50	1¼"	997	1500	1600	1500	700	1403	230	3050
EN VTS PEM 6G/12A ELC+S4/32	50	80 - F50	1¼"	997	1500	1600	1500	700	1404	230	3050
EN VTS PEM 6C/4A ELC+S4/11	65	80 - F50	1¼"	1050	1400	1400	1300	600	1405	230	3050
EN VTS PEM 6C/6A ELC+S4/21	65	80 - F50	1¼"	1050	1400	1600	1500	600	1406	230	3050
EN VTS PEM 6C/8A ELC+S4/21	65	80 - F50	1¼"	1050	1500	1600	1500	700	1407	230	3050
EN VTS PEM 6C/10A ELC+S4/32	65	80 - F50	1¼"	1050	1500	1800	1700	700	1408	230	3050
EN VTS PEM 7L/3A ELC+S4/11	80	100 - F65	1¼"	1047	1400	1400	1300	600	1409	230	3050
EN VTS PEM 7L/4A ELC+S4/16	80	100 - F65	1¼"	1047	1400	1600	1500	600	1410	230	3050
EN VTS PEM 7L/5A ELC+S4/21	80	100 - F65	1¼"	1047	1500	1600	1500	700	1411	230	3050
EN VTS PEM 7L/6A ELC+S4/21	80	100 - F65	1¼"	1047	1500	1800	1700	700	1412	230	3050
EN VTS PEM 7L/7A ELC+S4/32	80	100 - F65	1¼"	1047	1500	1800	1700	700	1413	230	3050
EN VTS PEM 7L/8A EVC+S4/32	80	100 - F65	1¼"	1047	1500	1800	1700	700	1414	230	3050
EN VTS PEM 7L/9A EVC+S4/32	80	100 - F65	1¼"	1047	1500	1800	1700	700	1415	230	3050
EN VTS PEM 7C/2A ELC+S4/11	80	100 - F65	1¼"	1047	1400	1400	1300	600	1416	230	3050
EN VTS PEM 7C/3A ELC+S4/11	80	100 - F65	1¼"	1047	1500	1600	1500	700	1417	230	3050
EN VTS PEM 7C/4A ELC+S4/16	80	100 - F65	1¼"	1047	1500	1800	1700	700	1418	230	3050
EN VTS PEM 7C/5A EVC+S4/21	80	100 - F65	1¼"	1047	1500	1800	1700	700	1419	230	3050
EN VTS PEM 7C/6A EVC+S4/21	80	100 - F65	1¼"	1047	1500	1800	1700	700	1420	230	3050
EN VTS PEM 7C/7A EVC+S4/32	80	100 - F65	1¼"	1047	1500	1800	1700	700	1421	230	3050
EN VTS PEM 8B/2A ELC+S4/11	80	100 - F65	1¼"	1047	1400	1400	1300	600	1422	230	3050
EN VTS PEM 8B/3A ELC+S4/16	80	100 - F65	1¼"	1047	1500	1600	1500	700	1423	230	3050
EN VTS PEM 8B/4A ELC+S4/21	80	100 - F65	1¼"	1047	1500	1800	1700	700	1424	230	3050
EN VTS PEM 8B/5A EVC+S4/32	80	100 - F65	1¼"	1047	1500	1800	1700	700	1425	230	3050
EN VTS PEM 8B/6A EVC+S4/32	80	100 - F65	1¼"	1047	1500	1800	1700	700	1426	230	3050

IDROFIRE VTS PEM

DIMENSIONI DIMENSIONS

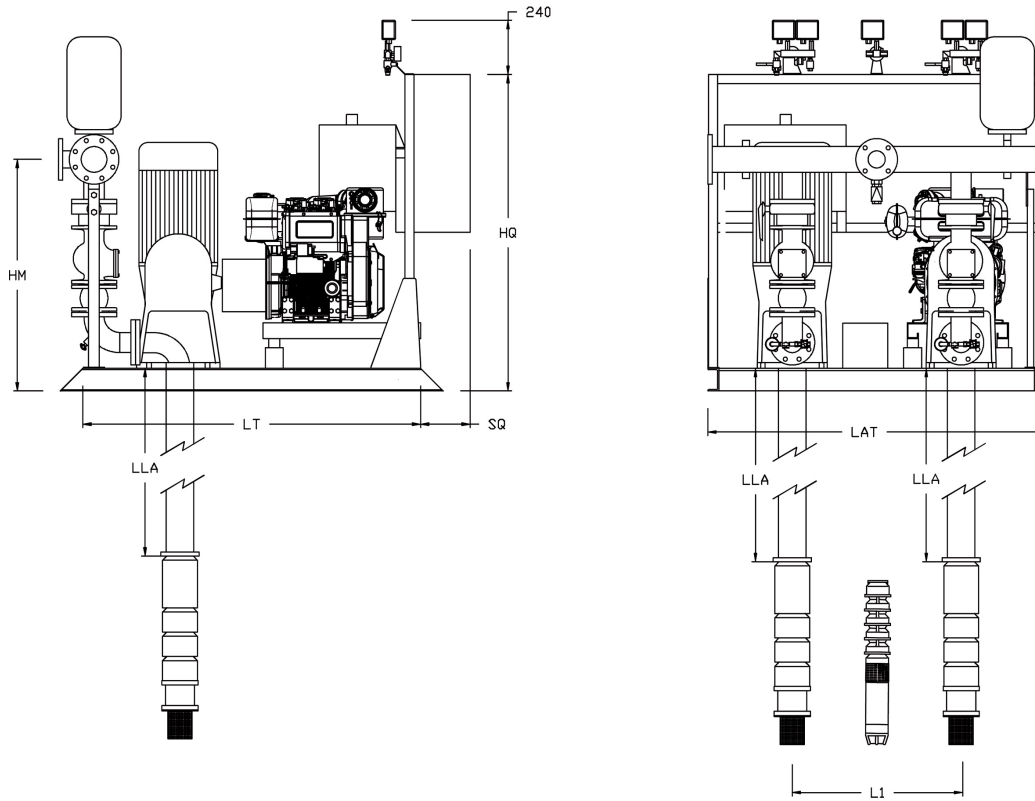

MODELLO GRUPPO	MANDATA kit valvole	collettore	PILOTA	HM	LAT	LT	LC	L1	HQ	SQ	LLA
MODEL GROUP	DELIVERY valves kit	manifold	JOCKEY PUMP	HM	LAT	LT	LC	L1	HQ	SQ	LLA
VTS PEM	DN	DN	DN AxM	mm	mm	mm	mm	mm	mm	mm	mm
EN VTS PEM 8F/2A ELC+S4/11	80	100 - F65	1¼"	1047	1400	1600	1500	600	1427	230	3050
EN VTS PEM 8F/3A ELC+S4/16	80	100 - F65	1¼"	1047	1500	1600	1500	700	1428	230	3050
EN VTS PEM 8F/4A ELC+S4/21	80	100 - F65	1¼"	1047	1500	1800	1700	700	1429	230	3050
EN VTS PEM 8F/5A EVC+S4/21	80	100 - F65	1¼"	1047	1500	1800	1700	700	1430	230	3050
EN VTS PEM 8F/6A EVC+S4/32	80	100 - F65	1¼"	1047	1500	1800	1700	700	1431	230	3050
EN VTS PEM 8L/2A ELC+S4/11	100	125 - F80	1¼"	1169	1400	1600	1500	600	1432	230	3050
EN VTS PEM 8L/3A ELC+S4/16	100	125 - F80	1¼"	1169	1500	1800	1700	700	1433	230	3050
EN VTS PEM 8L/4A EVC+S4/21	100	125 - F80	1¼"	1199	1500	2000	1900	700	1434	230	3050
EN VTS PEM 8L/5A EVC+S4/21	100	125 - F80	1¼"	1199	1500	2000	1900	700	1435	230	3050
EN VTS PEM 8L/6A EVC+S4/32	100	125 - F80	1¼"	1199	1500	2000	1900	700	1436	230	3050
EN VTS PEM 8C/2A ELC+S4/11	100	125 - F80	1¼"	1169	1500	1600	1500	700	1437	230	3050
EN VTS PEM 8C/3A EVC+S4/16	100	125 - F80	1¼"	1199	1500	2000	1900	700	1438	230	3050
EN VTS PEM 8C/4A EVC+S4/21	100	125 - F80	1¼"	1199	1500	2000	1900	700	1439	230	3050
EN VTS PEM 8C/5A EVC+S4/32	100	125 - F80	1¼"	1199	1500	2000	1900	700	1440	230	3050
EN VTS PEM 8C/6A EVC+S4/32	100	125 - F80	1¼"	1199	1500	2300	2200	700	1441	230	3050
EN VTS PEM 10F/1B EVC+S4/11	150	200 - F125	1¼"	1464	1500	2000	1900	700	1442	230	3050
EN VTS PEM 10F/1A EVC+S4/11	150	200 - F125	1¼"	1464	1500	2000	1900	700	1443	230	3050
EN VTS PEM 10F/2E EVC+S4/11	150	200 - F125	1¼"	1464	1500	2000	1900	700	1444	230	3050
EN VTS PEM 10F/2CD EVC+S4/16	150	200 - F125	1¼"	1464	1500	2300	2200	700	1445	230	3050
EN VTS PEM 10F/2BC EVC+S4/16	150	200 - F125	1¼"	1464	1500	2300	2200	700	1446	330	3050
EN VTS PEM 10F/3CD EVC+S4/21	150	200 - F125	1¼"	1464	1600	2500	2400	700	1447	330	3050
EN VTS PEM 10F/3B EVC+S4/21	150	200 - F125	1¼"	1464	1600	2500	2400	700	1448	330	3050
EN VTS PEM 12B/1B EVC+S4/11	150	200 - F125	1¼"	1464	1500	2000	1900	700	1449	230	3050
EN VTS PEM 12B/1A EVC+S4/11	150	200 - F125	1¼"	1464	1500	2000	1900	700	1450	230	3050
EN VTS PEM 12B/2C EVC+S4/21	150	200 - F125	1¼"	1464	1500	2300	2200	700	1451	330	3050
EN VTS PEM 12B/2B EVC+S4/21	150	200 - F125	1¼"	1464	1500	2500	2400	700	1452	330	3050
EN VTS PEM 12B/3C EVC+S4/32	150	200 - F125	1¼"	1464	1600	2500	2400	700	1453	330	3050

IDROFIRE VTS P2M

N.1 MOTOPOMPA DI SERVIZIO + N.1 MOTOPOMPA DI RISERVA + PILOTA

NR.1 MAIN DIESEL MOTORPUMP + NR.1 BACKUP DIESEL MOTOR PUMP + JOCKEY PUMP

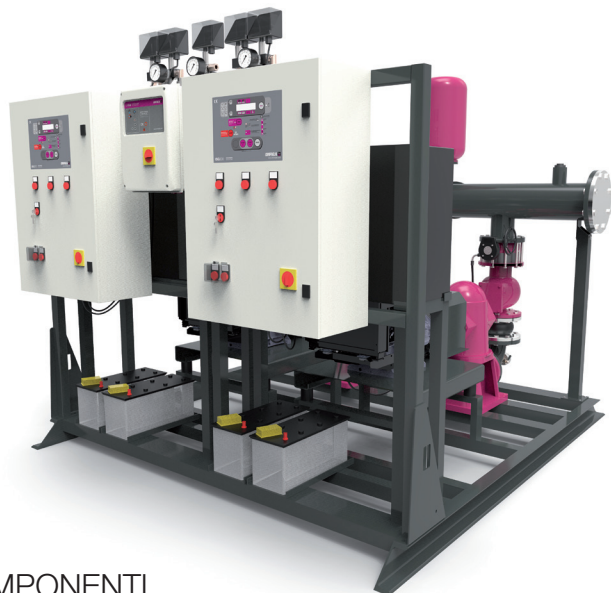

ELENCO COMPONENTI COMPONENT LIST

- | | |
|---|---|
| <ol style="list-style-type: none"> 1. Pompa di servizio del tipo verticale 1A. Pompa di riserva del tipo verticale 2. Linea d'asse per pompa di servizio e pompa di riserva 3. Gruppo di comando con rinvio ad angolo per collegamento tra pompe e motore Diesel 4. Motore Diesel per alimentazione pompa di servizio e di riserva 5. Elettropompa pilota sommersa 6. Valvola di ritegno a clapet 7. Valvola di intercettazione lucchettabile 8. Valvola di ritegno 9. Valvola di intercettazione a sfera con leva 10. Collettore di mandata reversibile completo di flangia cieca 11. Derivazione per collettore di prova di portata 12. Predisposizione per kit sprinkler 13. Kit avviamento per pompe principali composto da 2 pressostati 2-14 bar con pulsante di prova integrato, 1 manometro 0-16 bar e circuito by-pass 14. Kit avviamento per pompa pilota composto da 1 pressostato con pulsante di prova integrato, 1 manometro 15. Quadri elettrici di comando (uno per ogni pompa) 16. Kit diaframma di ricircolo completo di indicatore visivo di flusso 17. Manometro 0-16 bar 18. Serbatoio Autoclave 24 lt PN16 19. Giunto di compensazione in gomma 20. Curva 90° biflangiata 21. Serbatoio gasolio per motore Diesel 22. Giunti antivibranti in gomma 23. Telaio | <ol style="list-style-type: none"> 1. Service vertical pump 1A. Backup vertical pump 2. Shaft line for service and backup pump 3. Drive unit to link the pumps and diesel engine 4. Diesel engine for service pump and backup pump 5. Submersible jockey pump 6. Swing Check Valve ("Clapet" Valve) 7. Shut-off valve lockable 8. Check valve 9. Ball valve with level 10. Reversible delivery manifold with blind flange 11. Shunt for flow meter 12. Predisposition for sprinkler kit 13. Starting kit for main pump composed by 2 pressure switch 2-14 bar with integrated test button, 1 pressure gauge 0-16 bar and by-pass circuit 14. Starting kit for jockey electric pump composed by 1 pressure switch with integrated test button, 1 pressure gauge 15. Electrical control panels (one for each pump) 16. Kit recycling diaphragm complete with visual flow indicator 17. Pressure gauge 0-16 bar 18. Diaphragm pressure vessel 24LT PN16 19. Rubber strain neutralizer 20. biflanged 90° curve 21. Fuel tank for diesel engine 22. Rubber anti-vibration joints 23. Frame |
|---|---|

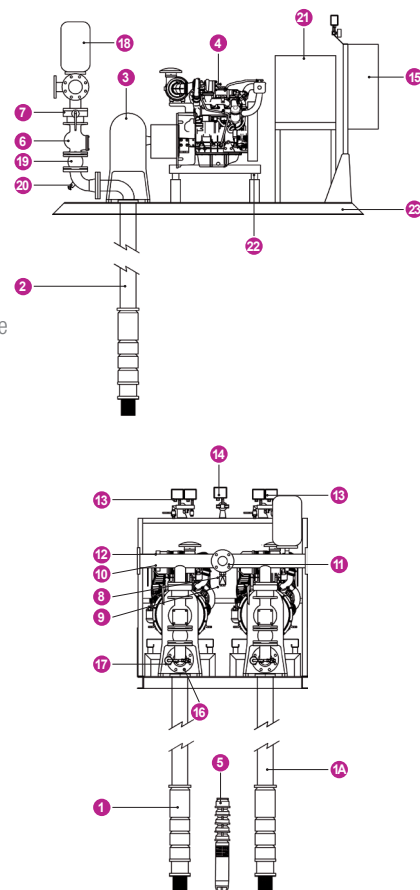

DROFIRE VTS P2M

DATI TECNICI TECHNICAL DATA

MODELLO GRUPPO	MOTOPOMPA					ELETTROPOMPA PILOTA		LINEA D'ASSE	KIT FLUSSIMETRO
	motore diesel			rinvio ad angolo		JOCKEY PUMP		LINESHAFT	FLOW METER KIT
MODEL GROUP	MOTOR PUMP			right angle drive unit					
	diesel engine								
VTS P2M	mod.	kW NA	kW NB	mod.	DN	mod.	kW	mod.	mod.
EN VTS P2M 6G/4A LC+S4/11	15LD440	6,2	6,7	R16/3L/20	80	S4/11	0,75	LA3/20	CM50 - V50
EN VTS P2M 6G/6A LC+S4/16	25LD425	10,4	11,5	R16/3L/20	80	S4/16	1,1	LA3/20	CM50 - V50
EN VTS P2M 6G/8A LC+S4/21	12LD477/2	13,6	15	R16/3L/20	80	S4/21	1,5	LA3/20	CM50 - V50
EN VTS P2M 6G/10A LC+S4/32	9LD625/2	17	18,9	R16/3L/20	80	S4/32	2,2	LA3/20	CM50 - V50
EN VTS P2M 6G/12A LC+S4/32	9LD625/2	17	18,9	R16/3L/20	80	S4/32	2,2	LA3/20	CM50 - V50
EN VTS P2M 6C/4A LC+S4/11	25LD425	10,4	11,5	R16/3L/20	80	S4/11	0,75	LA3/20	CM65 - V50
EN VTS P2M 6C/6A LC+S4/21	12LD477/2	13,6	15	R16/3L/20	80	S4/21	1,5	LA3/20	CM65 - V50
EN VTS P2M 6C/8A LC+S4/21	9LD625/2	17	18,9	R16/3L/20	80	S4/21	1,5	LA3/20	CM65 - V50
EN VTS P2M 6C/10A LC+S4/32	11LD626/3	24	26	R16/3L/24	80	S4/32	2,2	LA3/24	CM65 - V50
EN VTS P2M 7L/3A LC+S4/11	25LD425	10,4	11,5	R16/3L/20	80	S4/11	0,75	LA3/20	CM65 - V65
EN VTS P2M 7L/4A LC+S4/16	12LD477/2	13,6	15	R16/3L/20	80	S4/16	1,1	LA3/20	CM65 - V65
EN VTS P2M 7L/5A LC+S4/21	9LD625/2	17	18,9	R16/3L/20	80	S4/21	1,5	LA3/20	CM65 - V65
EN VTS P2M 7L/6A LC+S4/21	11LD626/3	24	26	R16/3L/20	80	S4/21	1,5	LA3/20	CM65 - V65
EN VTS P2M 7L/7A LC+S4/32	11LD626/3	24	26	R16/3L/24	80	S4/32	2,2	LA3/24	CM65 - V65
EN VTS P2M 7L/8A VC+S4/32	D703LE0	33	37	R16/3L/24	80	S4/32	2,2	LA3/24	CM65 - V65
EN VTS P2M 7L/9A VC+S4/32	D703LE0	33	37	R16/3L/24	80	S4/32	2,2	LA3/24	CM65 - V65
EN VTS P2M 7C/2A LC+S4/11	25LD425	10,4	11,5	R16/4L/20	100	S4/11	0,75	LA4/20	CM80 - V65
EN VTS P2M 7C/3A LC+S4/11	9LD625/2	17	18,9	R16/4L/20	100	S4/11	0,75	LA4/20	CM80 - V65
EN VTS P2M 7C/4A LC+S4/16	11LD626/3	24	26	R16/4L/20	100	S4/16	1,1	LA4/20	CM80 - V65
EN VTS P2M 7C/5A VC+S4/21	D703LE0	33	37	R26/4L/24	100	S4/21	1,5	LA4/24	CM80 - V65
EN VTS P2M 7C/6A VC+S4/21	D703LE0	33	37	R26/4L/24	100	S4/21	1,5	LA4/24	CM80 - V65
EN VTS P2M 7C/7A VC+S4/32	D703LTE0	48	53	R26/4L/24	100	S4/32	2,2	LA4/24	CM80 - V65
EN VTS P2M 8B/2A LC+S4/11	25LD425	10,4	11,5	R16/3L/20	80	S4/11	0,75	LA3/20	CM65 - V65
EN VTS P2M 8B/3A LC+S4/16	9LD625/2	17	18,9	R16/3L/20	80	S4/16	1,1	LA3/20	CM65 - V65
EN VTS P2M 8B/4A LC+S4/21	11LD626/3	24	26	R16/3L/20	80	S4/21	1,5	LA3/20	CM65 - V65
EN VTS P2M 8B/5A VC+S4/32	D703LE0	33	37	R26/3L/24	80	S4/32	2,2	LA3/24	CM65 - V65
EN VTS P2M 8B/6A VC+S4/32	D703LE0	33	37	R26/3L/24	80	S4/32	2,2	LA3/24	CM65 - V65
EN VTS P2M 8F/2A LC+S4/11	12LD477/2	13,6	15	R16/4L/20	100	S4/11	0,75	LA4/20	CM80 - V65
EN VTS P2M 8F/3A LC+S4/16	9LD625/2	17	18,9	R16/4L/20	100	S4/16	1,1	LA4/20	CM80 - V65
EN VTS P2M 8F/4A LC+S4/21	11LD626/3	24	26	R26/4L/24	100	S4/21	1,5	LA4/24	CM80 - V65
EN VTS P2M 8F/5A VC+S4/21	D703LE0	33	37	R26/4L/24	100	S4/21	1,5	LA4/24	CM80 - V65
EN VTS P2M 8F/6A VC+S4/32	D703LTE0	48	53	R26/4L/24	100	S4/32	2,2	LA4/24	CM80 - V65
EN VTS P2M 8L/2A LC+S4/11	12LD477/2	13,6	15	R16/5/20	125	S4/11	0,75	LA5/20	CM80 - V80
EN VTS P2M 8L/3A LC+S4/16	11LD626/3	24	26	R16/5/20	125	S4/16	1,1	LA5/20	CM80 - V80
EN VTS P2M 8L/4A VC+S4/21	D703LE0	33	37	R26/5/24	125	S4/21	1,5	LA5/24	CM80 - V80
EN VTS P2M 8L/5A VC+S4/21	D703LE0	33	37	R26/5/24	125	S4/21	1,5	LA5/24	CM80 - V80
EN VTS P2M 8L/6A VC+S4/32	D703LTE0	48	53	R26/5/24	125	S4/32	2,2	LA5/24	CM80 - V80
EN VTS P2M 8C/2A LC+S4/11	9LD625/2	17	18,9	R16/5/20	125	S4/11	0,75	LA5/20	CM100 - V80
EN VTS P2M 8C/3A VC+S4/16	D703LE0	33	37	R26/5/24	125	S4/16	1,1	LA5/24	CM100 - V80
EN VTS P2M 8C/4A VC+S4/21	D703LTE0	48	53	R26/5/24	125	S4/21	1,5	LA5/24	CM100 - V80
EN VTS P2M 8C/5A VC+S4/32	D703LTE0	48	53	R42/5/30	125	S4/32	2,2	LA5/30	CM100 - V80
EN VTS P2M 8C/6A VC+S4/32	D754TPE2	65	73	R42/5/30	125	S4/32	2,2	LA5/30	CM100 - V80
EN VTS P2M 10F/1B VC+S4/11	D703LE0	33	37	R26/6/24	125	S4/11	0,75	LA6/24	CM150 - V125
EN VTS P2M 10F/1A VC+S4/11	D703LTE0	48	53	R26/6/30	150	S4/11	0,75	LA6/30	CM150 - V125
EN VTS P2M 10F/2E VC+S4/11	D703LTE0	48	53	R42/6/30	150	S4/11	0,75	LA6/30	CM150 - V125
EN VTS P2M 10F/2CD VC+S4/16	D754TPE2	65	73	R42/6/30	150	S4/16	1,1	LA6/30	CM150 - V125
EN VTS P2M 10F/2BC VC+S4/16	D754TPE2	65	73	R42/6/30	150	S4/16	1,1	LA6/30	CM150 - V125
EN VTS P2M 10F/3CD VC+S4/21	D756IPE2	100	110	R75/6/30	150	S4/21	1,5	LA6/30	CM150 - V125
EN VTS P2M 10F/3B VC+S4/21	D756IPE2	100	110	R75/6/30	150	S4/21	1,5	LA6/30	CM150 - V125
EN VTS P2M 12B/1B VC+S4/11	D703LTE0	48	53	R26/7/30	175	S4/11	0,75	LA7/30	CM125 - V125
EN VTS P2M 12B/1A VC+S4/11	D703LTE0	48	53	R42/7/30	175	S4/11	0,75	LA7/30	CM125 - V125
EN VTS P2M 12B/2C VC+S4/21	D754TPE2	65	73	R75/7/30	175	S4/21	1,5	LA7/30	CM125 - V125
EN VTS P2M 12B/2B VC+S4/21	D756IPE2	100	110	R75/7/30	175	S4/21	1,5	LA7/30	CM125 - V125
EN VTS P2M 12B/3C VC+S4/32	D756IPE2	100	110	R75/7/30	175	S4/32	2,2	LA7/30	CM125 - V125

IDROFIRE VTS P2M

DIMENSIONI DIMENSIONS

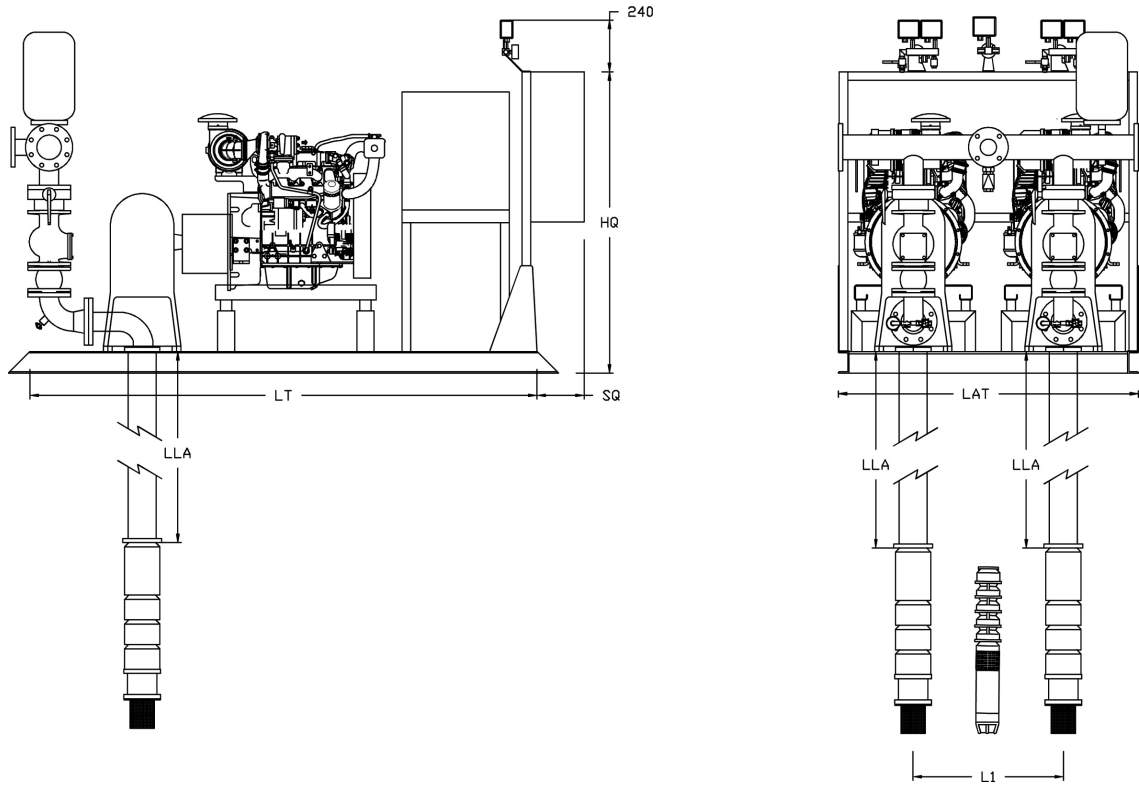

MODELLO GRUPPO	MANDATA kit valvole	collettore	PILOTA	HM	LAT	LT	LC	L1	HQ	SQ	LLA
MODEL GROUP	DELIVERY valves kit	manifold	JOCKEY PUMP	HM	LAT	LT	LC	L1	HQ	SQ	LLA
VTS P2M	DN	DN	DN AxM	mm	mm	mm	mm	mm	mm	mm	mm
EN VTS P2M 6G/4A LC+S4/11	50	80 - F50	1¼"	997	1400	1600	1300	600	1400	230	3050
EN VTS P2M 6G/6A LC+S4/16	50	80 - F50	1¼"	997	1400	1800	1300	600	1401	230	3050
EN VTS P2M 6G/8A LC+S4/21	50	80 - F50	1¼"	997	1400	200	1300	600	1402	230	3050
EN VTS P2M 6G/10A LC+S4/32	50	80 - F50	1¼"	997	1500	2000	1400	700	1403	230	3050
EN VTS P2M 6G/12A LC+S4/32	50	80 - F50	1¼"	997	1500	2000	1400	700	1404	230	3050
EN VTS P2M 6C/4A LC+S4/11	65	80 - F50	1¼"	1050	1400	1800	1300	600	1405	230	3050
EN VTS P2M 6C/6A LC+S4/21	65	80 - F50	1¼"	1050	1400	2000	1300	600	1406	230	3050
EN VTS P2M 6C/8A LC+S4/21	65	80 - F50	1¼"	1050	1500	2000	1400	700	1407	230	3050
EN VTS P2M 6C/10A LC+S4/32	65	80 - F50	1¼"	1050	1500	2300	1400	700	1408	230	3050
EN VTS P2M 7L/3A LC+S4/11	80	100 - F65	1¼"	1047	1400	1800	1300	600	1409	230	3050
EN VTS P2M 7L/4A LC+S4/16	80	100 - F65	1¼"	1047	1400	2000	1300	600	1410	230	3050
EN VTS P2M 7L/5A LC+S4/21	80	100 - F65	1¼"	1047	1500	2000	1400	700	1411	230	3050
EN VTS P2M 7L/6A LC+S4/21	80	100 - F65	1¼"	1047	1500	2300	1400	700	1412	230	3050
EN VTS P2M 7L/7A LC+S4/32	80	100 - F65	1¼"	1047	1500	2300	1400	700	1413	230	3050
EN VTS P2M 7L/8A VC+S4/32	80	100 - F65	1¼"	1047	1500	2300	1400	700	1414	230	3050
EN VTS P2M 7L/9A VC+S4/32	80	100 - F65	1¼"	1047	1500	2300	1400	700	1415	230	3050
EN VTS P2M 7C/2A LC+S4/11	80	100 - F65	1¼"	1047	1400	1800	1300	600	1416	230	3050
EN VTS P2M 7C/3A LC+S4/11	80	100 - F65	1¼"	1047	1500	2000	1400	700	1417	230	3050
EN VTS P2M 7C/4A LC+S4/16	80	100 - F65	1¼"	1047	1500	2300	1400	700	1418	230	3050
EN VTS P2M 7C/5A VC+S4/21	80	100 - F65	1¼"	1047	1500	2300	1400	700	1419	230	3050
EN VTS P2M 7C/6A VC+S4/21	80	100 - F65	1¼"	1047	1500	2300	1400	700	1420	230	3050
EN VTS P2M 7C/7A VC+S4/32	80	100 - F65	1¼"	1047	1500	2300	1400	700	1421	230	3050
EN VTS P2M 8B/2A LC+S4/11	80	100 - F65	1¼"	1047	1400	1800	1300	600	1422	230	3050
EN VTS P2M 8B/3A LC+S4/16	80	100 - F65	1¼"	1047	1500	2000	1400	700	1423	230	3050
EN VTS P2M 8B/4A LC+S4/21	80	100 - F65	1¼"	1047	1500	2300	1400	700	1424	230	3050
EN VTS P2M 8B/5A VC+S4/32	80	100 - F65	1¼"	1047	1500	2300	1400	700	1425	230	3050
EN VTS P2M 8B/6A VC+S4/32	80	100 - F65	1¼"	1047	1500	2300	1400	700	1426	230	3050

IDROFIRE VTS P2M

DIMENSIONI DIMENSIONS

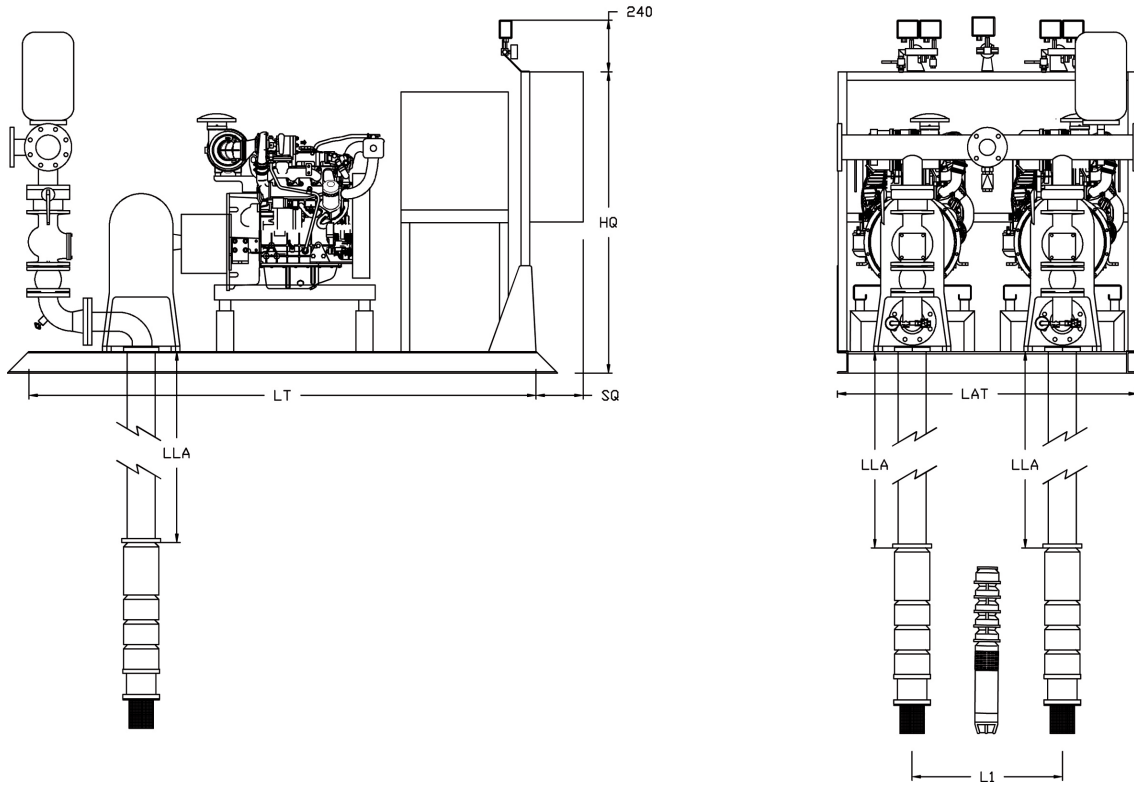

MODELLO GRUPPO	MANDATA kit valvole	collettore	PILOTA	HM	LAT	LT	LC	L1	HQ	SQ	LLA
MODEL GROUP	DELIVERY valves kit	manifold	JOCKEY PUMP	HM	LAT	LT	LC	L1	HQ	SQ	LLA
VTS P2M	DN	DN	DN AxM	mm	mm	mm	mm	mm	mm	mm	mm
EN VTS P2M 8F/2A LC+S4/11	80	100 - F65	1¼"	1047	1400	2000	1300	600	1427	230	3050
EN VTS P2M 8F/3A LC+S4/16	80	100 - F65	1¼"	1047	1500	2000	1400	700	1428	230	3050
EN VTS P2M 8F/4A LC+S4/21	80	100 - F65	1¼"	1047	1500	2300	1400	700	1429	230	3050
EN VTS P2M 8F/5A VC+S4/21	80	100 - F65	1¼"	1047	1500	2300	1400	700	1430	230	3050
EN VTS P2M 8F/6A VC+S4/32	80	100 - F65	1¼"	1047	1500	2300	1400	700	1431	230	3050
EN VTS P2M 8L/2A LC+S4/11	100	125 - F80	1¼"	1169	1400	2000	1300	600	1432	230	3050
EN VTS P2M 8L/3A LC+S4/16	100	125 - F80	1¼"	1169	1500	2300	1400	700	1433	230	3050
EN VTS P2M 8L/4A VC+S4/21	100	125 - F80	1¼"	1169	1500	2300	1400	700	1434	230	3050
EN VTS P2M 8L/5A VC+S4/21	100	125 - F80	1¼"	1169	1500	2300	1400	700	1435	230	3050
EN VTS P2M 8L/6A VC+S4/32	100	125 - F80	1¼"	1169	1500	2300	1400	700	1436	230	3050
EN VTS P2M 8C/2A LC+S4/11	100	125 - F80	1¼"	1169	1500	2000	1400	700	1437	230	3050
EN VTS P2M 8C/3A VC+S4/16	100	125 - F80	1¼"	1169	1500	2300	1400	700	1438	230	3050
EN VTS P2M 8C/4A VC+S4/21	100	125 - F80	1¼"	1169	1500	2300	1400	700	1439	230	3050
EN VTS P2M 8C/5A VC+S4/32	100	125 - F80	1¼"	1199	1500	2500	1400	700	1440	230	3050
EN VTS P2M 8C/6A VC+S4/32	100	125 - F80	1¼"	1199	1500	2500	1400	700	1441	230	3050
EN VTS P2M 10F/1B VC+S4/11	150	200 - F125	1¼"	1434	1500	2500	1400	700	1442	230	3050
EN VTS P2M 10F/1A VC+S4/11	150	200 - F125	1¼"	1464	1500	2500	1400	700	1443	230	3050
EN VTS P2M 10F/2E VC+S4/11	150	200 - F125	1¼"	1464	1500	2500	1400	700	1444	230	3050
EN VTS P2M 10F/2CD VC+S4/16	150	200 - F125	1¼"	1464	1500	2700	1400	700	1445	230	3050
EN VTS P2M 10F/2BC VC+S4/16	150	200 - F125	1¼"	1464	1500	2700	1400	700	1446	230	3050
EN VTS P2M 10F/3CD VC+S4/21	150	200 - F125	1¼"	1464	1600	3000	1500	700	1447	230	3050
EN VTS P2M 10F/3B VC+S4/21	150	200 - F125	1¼"	1464	1600	3000	1500	700	1448	230	3050
EN VTS P2M 12B/1B VC+S4/11	150	200 - F125	1¼"	1464	1500	2500	1400	700	1449	230	3050
EN VTS P2M 12B/1A VC+S4/11	150	200 - F125	1¼"	1464	1500	2500	1400	700	1450	230	3050
EN VTS P2M 12B/2C VC+S4/21	150	200 - F125	1¼"	1464	1500	2700	1400	700	1451	230	3050
EN VTS P2M 12B/2B VC+S4/21	150	200 - F125	1¼"	1464	1500	3000	1400	700	1452	230	3050
EN VTS P2M 12B/3C VC+S4/32	150	200 - F125	1¼"	1464	1600	3000	1500	700	1453	230	3050



IDROFIRE SM P1E



IDROFIRE SM P2E

VOCE DI CAPITOLATO

Fornitura e posa in opera di gruppo di pressurizzazione antincendio, tipo IDROFOGLIA a norma EN12845 modello Hydrofire SM con elettropompe sommerse, composto da:

Sezione Elettropompa pilota

n.1 elettropompa pilota del tipo sommersa, per il mantenimento della pressione all'interno dell'anello antincendio, con elementi in fusione di acciaio inossidabile, giranti radiali, albero pompa e giunto di trasmissione in acciaio inossidabile, accoppiata a motore elettrico sommerso asincrono trifase con rotore in corto circuito, flangiatura Nema, 2 poli, grado di protezione IP 68, classe di isolamento B. La pompa pilota è corredata in mandata di una valvola di ritegno, una valvola a sfera, un vaso di espansione 20 litri PN16, e raccordi per il collegamento al quadro di comando. La pompa è comandata in automatico da un quadro in lamiera zincata con applicato un pressostato di avviamento regolabile con grado di protezione IP55, manometro e circuito di prova del pressostato. L'elettropompa pilota è comandata da un quadro di controllo indipendente costruito secondo norma EN12845, in lamiera verniciata con grado di protezione IP55 ad avviamento diretto, così composto:

- interruttore blocco porta fusibilitato
- contattore e relè termico
- selettore Manuale – 0 – Automatico a chiave
- lampada di avviamento, di blocco, di presenza rete
- trasformatore 400/24/12V per circuito ausiliario
- fusibili per circuito ausiliario
- morsettiera e pressacavi
- alimentazione 400 (3F) 50 Hz

Sezione Elettropompa di servizio

n.1 elettropompa di servizio del tipo sommersa, radiale e semiassiale, con albero pompa pompa e giunto in acciaio inossidabile, girante e diffusore in resina termoplastica o ghisa, accoppiata a motore elettrico sommerso riavvolgibile, asincrono trifase, accoppiamento a parti idrauliche Nema, 2 poli. La pompa di servizio è corredata in mandata di un giunto in gomma di compensazione, un aumento flangiato per garantire una velocità dell'acqua pari a 6 m/s, un diaframma calibrato in ottone da 3/8" per il ricircolo e lo scarico dell'aria della pompa, un manometro, una valvola di non ritorno ispezionabile, un diaframma zincato con uscita da 1/2" per il collegamento al quadro di avviamento della pompa e una valvola a farfalla d'intercettazione. La pompa è comandata in automatico da un pannello di controllo in lamiera zincata, collegato al diaframma mediante un tubo RILSAN 2034 15/12.5 pa12, dove si trovano 2 pressostati di avviamento regolabili con grado di protezione IP55, manometro e circuito di prova dei pressostati. Sul collettore di mandata vi è la predisposizione per il collettore di prova, il collettore è sorretto da 2 gambe collegate al telaio principale, per garantire la stabilità e la continuità del servizio anche se si interviene su di una pompa. L'elettropompa principale è comandata da un quadro di controllo indipendente costruito secondo norma EN12845, in lamiera verniciata con grado di protezione IP55 ad avviamento diretto (fino a 9,2 kW) ed avviamento stella-triangolo (da 11 kW) così composto:

- interruttore blocco porta
- scheda elettronica di gestione programmabile con spie e led di segnalazione
- prova settimanale integrata
- presa interbloccata di servizio monofase 16 A
- selettore Manuale – 0 – Automatico a chiave
- pulsanti di marcia e arresto
- relè mancanza fase e sequenza fase
- batteria a tampone con carica batteria
- trasformatore 400/24/12V per circuiti ausiliari
- fusibili per circuito ausiliario e generali
- n. 3 contattori
- temporizzatore di scambio
- amperometro e voltmetro con commutatore voltmetrico;
- lampeggiante con avvisatore acustico
- morsettiera
- alimentazione 400 (3F+N) 50 Hz

Quadri, e valvolame sono installati su un telaio realizzato in acciaio zincato.

ACCESSORI A CORREDO

- Kit Flussimetro adeguatamente dimensionato, composto da:
 - Flussimetro a lettura rinviata
 - Collettore in acciaio zincato
 - Valvola di intercettazione
- Quadro allarme acustico-luminoso di remotazione allarme
- Camicia di raffreddamento in acciaio zincato per elettropompa di servizio
- Camicia di raffreddamento in acciaio zincato per posizionamento elettropompa pilota

PROJECT DESCRIPTION

Fire Fighting Unit IDROFOGLIA with pressurization unit according to EN12845 HYDRO-FIRE SM model with submersible pumps, composed by:

Jockey Pump Section

Nr. 1 submersible jockey pump for the maintenance of the proper water pressure into the firewater ring main, with parts made of stainless steel, radiant impellers, stainless steel shaft and shaft coupling, coupled with submersible asynchronous electrical engine with squirrel-cage armature, Nema flange, 2 poles, IP68 protection, B insulation class.

The jockey pump is equipped on delivery with one check valve, one ball valve, a 20 liters expansion tank PN16, and fittings for control panel connection.

The pump is automatically controlled by a galvanized control panel with an adjustable starting pressure switch IP55 protection level, gauge and pressure switch testing circuit. The jockey electric pump is controlled by an independently control panel manufactured according to EN 12845 norm, with painted IP55 protection level sheet metal, automatic starter, composed by:

- door locking switch
- contactor and overload relay
- manual selector lever 0 automatic with key
- starting signal light, block signal light, main present signal light
- transformer 400/24/12V for auxiliary circuits
- auxiliary circuit fuses
- terminal board and cable glands
- power input 400 (3F) 50 Hz

Service Electric Pump Section

Nr. 1 submersible electric pump, radial and semi-axial, stainless steel shaft and shaft coupling, thermoplastic resin other cast iron impeller and nozzle, coupled with electrical submersible and rewinding engine, asynchronous and three phase, Nema hydraulic parts coupling, 2 poles.

The service pump has a flanged rubber joint, a taper pipe flanged to guarantee 6 m/s, a brass orifice plate of 3/8" air pump recycle and reject, a manometer, an inspected non return valve, a galvanized diaphragm with 1/2" output for pump started panel connection and a shut-off butterfly valve.

The pumps are automatically controlled by galvanized control panel, connected to the diaphragm by RILSAN 2034 15/12.5 pa12 hose, where there are 2 adjustable starting pressure with IP55 level protection, gauge and pressure circuit test.

The main electric pump is controlled by and independently control panel manufactured according to EN 12845 norm, with painted IP55 protection level sheet metal, automatic starter (until 9,2 kW) and star delta starting (from 11 kW) composed by:

- door lock switches
- programmable electronic management with indicator led and light
- integrated weekly test
- interlocked mono-phase 16A service power point
- manual selector level 0 automatic with key
- start and stop buttons
- phase failure and phase sequence relay
- buffer battery with charger
- transformer 400/24/12V for auxiliary circuits
- auxiliary circuit fuses and general fuses
- nr. 3 contactors
- swap timer
- ampere meter, voltmeter with voltmeter switch
- flashing with buzzer
- terminal board
- power input 400 (3F+N) 50 Hz

Panels and valves are installed on a stainless steel frame.

ACCESSORIES

- Flow meter Kit adequately sized, composed by:
 - Postponed reading flow meter;
 - Galvanized steel manifold;
 - Shut off valve
- Control panel for alarm maintaining with remote control. Control panel for A and B alarms grouping with the possibility to connect sirens and to interface it, through clean contacts, with the eventual supervision system;
- Stainless steel cooling chambers to position the service electro pump
- Stainless steel cooling chambers to position the jockey electro pump

PRESTAZIONI POMPE PUMPS PERFORMANCES

DATI TECNICI TECHNICAL DATA

PUMP MODEL	kW	m ³ /h l/min	hydraulic performance									
			0	5,4	6,3	7,2	8,1	9	10,2	11,4	12,6	13,8
EN ... 4T20 6/230	1,5	H (m.c.a)	56	51	49	46	43	40	35	29	22	15
EN ... 4TH30 9/230	2,2		84	75	72	68	64	59	52	44	34	24
EN ... 4T40 11/230	3		103	93	90	85	80	74	66	56	45	33

PUMP MODEL	kW	m ³ /h l/min	hydraulic performance										
			0	9	10,2	11,4	12,6	13,2	14,7	15,6	16,8	18	19,8
EN ... 4T40 7/330	3	H (m.c.a)	68	57	55	52	49	45	42	39	34	29	20
EN ... 4T55 9/330	4		89	74	71	66	62	56	52	47	41	34	24
EN ... 4T55 10/330	4		102	86	82	77	72	66	62	57	50	42	29
EN ... 6TA75 12/330	5,5		121	101	96	90	84	77	71	65	57	48	33

PUMP MODEL	kW	m ³ /h l/min	hydraulic performance								
			0	11,4	13,8	15,6	18	19,8	21,6	24	27
EN ... 4T55 6/400	4	H (m.c.a)	75	63	59	55	50	46	41	34	25
EN ... 6TA75 7/400	5,5		90	74	69	65	59	54	48	40	29
EN ... 6TA10 8/400	7,5		105	85	80	76	69	63	56	47	34
EN ... 6TA10 10/400	7,5		130	107	100	94	86	78	70	58	42

PUMP MODEL	kW	m ³ /h l/min	hydraulic performance										
			0	18	19,8	21,6	24	27	30	33	36	39	42
EN ... 6TA75 5/700	5,5	H (m.c.a)	68	59	57	55	51	46	41	35	28	21	14
EN ... 6TA10 6/700	7,5		84	68	66	63	59	54	48	42	34	27	17
EN ... 6TA125 8/700	9,2		113	93	91	87	83	76	69	60	50	40	29
EN ... 6TA15 10/700	11		141	116	114	110	104	96	86	75	62	50	36

PRESTAZIONI POMPE
PUMPS PERFORMANCES

DATI TECNICI TECHNICAL DATA

PUMP MODEL	kW	hydraulic performance											
		m ³ /h	0	24	27	30	33	36	39	42	48	54	60
		l/min	0	400	450	500	550	600	650	700	800	900	1000
EN ... 6TA125 5/900	9,2	H (m.c.a)	70	63	61	59	56	54	51	48	42	33	23
EN ... 6TA15 6/900	11		86	76	73,5	71	68	65	62	59	51	41	29
EN ... 6TA20 8/900	15		114	101	98	95	91	87	83	78	68	55	38

PUMP MODEL	kW	hydraulic performance									
		m ³ /h	0	30	36	42	48	60	72	84	90
		l/min	0	500	600	700	800	1000	1200	1400	1500
EN ... 6TA15 3/1500	11	H (m.c.a)	60	54	52	50	47	41	32	23	17
EN ... 6TA20 4/1500	15		79	72	69	66	62	54	43	30	23
EN ... 6TA25 5/1500	18,5		98	89	85	81	77	67	54	38	28
EN ... 6TA30 6/1500	22		117	107	103	98	93	80	65	46	35

PUMP MODEL	kW	hydraulic performance													
		m ³ /h	0	39,5	46,8	54	57,6	64,8	72	79,2	86,4	90	93,6	97,2	100,8
		l/min	0	658	780	900	960	1080	1200	1320	1440	1500	1560	1620	1680
EN ... E8S55/3A	15	H (m.c.a)	66	59	58	56	56	54	51	48	44,5	42	40	37,5	35
EN ... E8S55/4A	18,5		87	78	76	74	73	70	67	62	57	55	52	48,5	45
EN ... E8S55/5I	22		107	94	93	90	88	85	80	75	68	65	61	57	53
EN ... E8S55/5A	26		110	99	97	94	93	89	85	79	73	70	66	62	58

PUMP MODEL	kW	hydraulic performance													
		m ³ /h	0	72	90	108	115,2	122,4	129,6	136,8	144	151,2	154,8	158,4	162
		l/min	0	1200	1500	1800	1920	2040	2160	2280	2400	2520	2580	2640	2700
EN ... E8S64/3A	22	H (m.c.a)	73	63	58	54	52	49	46,5	43,5	40,5	37	35	33	32
EN ... E8S64/4K	26		89	74	68	62	58	55	52	45	42,5	37,5	35	32,5	30
EN ... E8S64/4A	30		97	83	78	72	67	65	61	57	52	48	45,5	43	41

IDROFIRE SM P1E

N.1 ELETTROPOMPA DI SERVIZIO + PILOTA
NR.1 MAIN ELECTRIC PUMP + JOCKEY PUMP



ELENCO COMPONENTI COMPONENT LIST

- | | |
|---|--|
| <ol style="list-style-type: none"> 1. Elettropompa di servizio Sommersa 2. Elettropompa Pilota Sommersa 3. Valvola di ritegno a clapet 4. Valvola di intercettazione lucchettabile 5. Valvola di ritegno 6. Valvola di intercettazione a sfera con leva 7. Collettore di mandata reversibile completo di flangia cieca 8. Derivazione per collettore di prova di portata 9. Predisposizione per kit sprinkler 10. Kit avviamento per pompe principali composto da 2 pressostati 2-14 bar con pulsante di prova integrato, 1 manometro 0-16 bar e circuito by-pass 11. Kit avviamento per pompa pilota composto da 1 pressostato con pulsante di prova integrato, 1 manometro 12. Quadri elettrici di comando (uno per ogni pompa) 13. Kit diaframma di ricircolo completo di indicatore visivo di flusso 14. Manometro 0-16 bar 15. Serbatoio Autoclave 24 lt PN16 16. Telaio | <ol style="list-style-type: none"> 1. Main submersible electric pump 2. Jockey submersible electric pump 3. Swing Check Valve ("Clapet" Valve) 4. Shut-off valve lockable 5. Check valve 6. Ball valve with level 7. Reversible delivery manifold with blind flange 8. Shunt for flow meter 9. Predisposition for sprinkler kit 10. Starting kit for main pump composed by 2 pressure switch 2-14 bar with integrated test button, 1 pressure gauge 0-16 bar and by-pass circuit 11. Starting kit for jockey electric pump composed by 1 pressure switch with integrated test button, 1 pressure gauge 12. Electrical control panels (one for each pump) 13. Kit recycling diaphragm complete with visual flow indicator 14. Pressure gauge 0-16 bar 15. Diaphragm pressure vessel 24LT PN16 16. Frame |
|---|--|

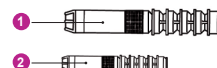
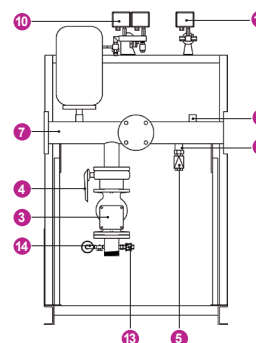
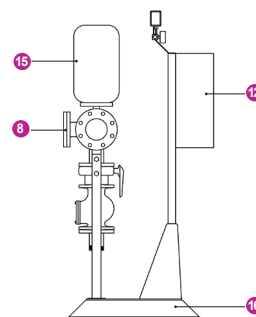

IDROFIRE SM P1E

DIMENSIONI DIMENSIONS

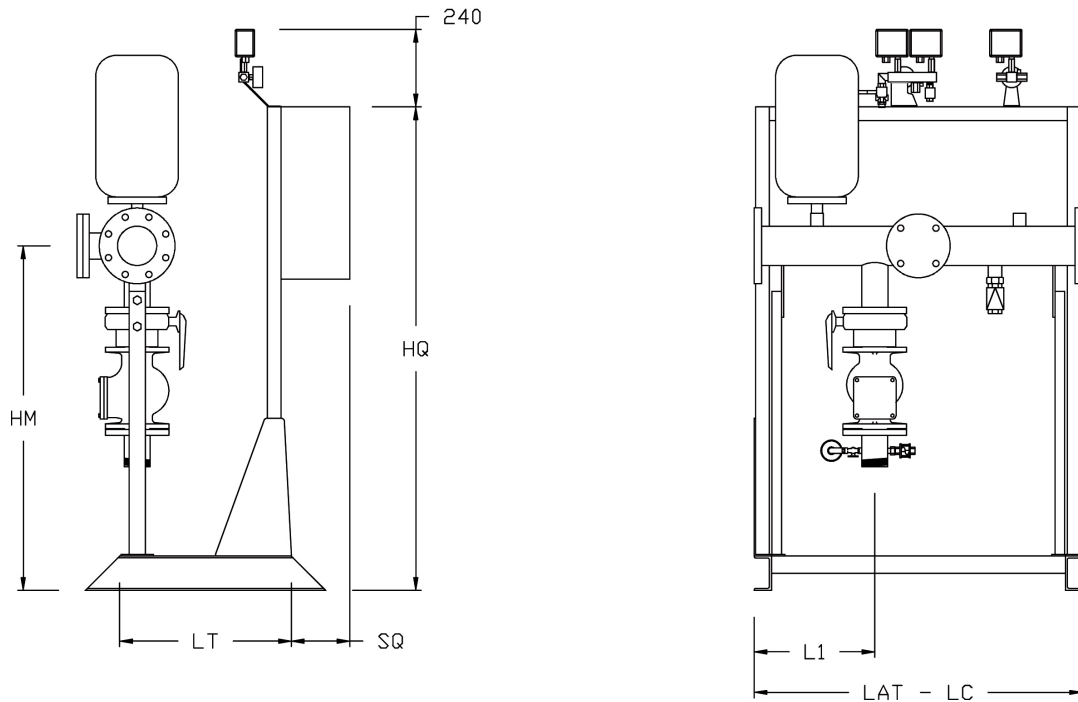

DATI TECNICI TECHNICAL DATA

MODELLO GRUPPO	POMPA PRINCIPALE			POMPA PILOTA			COLLETTORE DI MANDATA	KIT FLUSSIMETRO	DIMENSIONI MM								
	lung. cavo	kit valvole		mot. el.	lung. cavo				DIMENSION MM								
MODEL GROUP	MAIN PUMP length cable	valves kit		JOCKEY PUMP el. engine	length cable		DELIVERY MANIFOLD	FLOW METER KIT									
SM P1E	kW	m	DN	mod.	kW	m		mod.	bocca1	bocca2	Hq	Hm	La-Tc	Lt	L1	Lf	Sq
EN SM P1E 4T20 6/230+S12/60	1,5	2	50	S12/60	0,55	2	DN80 - F50	CM50 - V50	2"	1½"	1400	1000	800	700	300	400	70
EN SM P1E 4TH30 9/230+S15/60	2,2	2	50	S15/60	0,75	2	DN80 - F50	CM50 - V50	2"	1½"	1400	1000	800	700	300	400	70
EN SM P1E 4T40 11/230+S18/100	3	2	50	S18/100	1,5	2	DN80 - F50	CM50 - V50	2"	1½"	1400	1000	800	700	300	400	70
EN SM P1E 4T40 7/330+S15/60	3	2	50	S15/60	0,75	2	DN80 - F50	CM50 - V50	2"	1½"	1400	1000	800	700	300	400	70
EN SM P1E 4T55 9/330+S18/100	4	2	50	S18/100	1,5	2	DN80 - F50	CM50 - V50	2"	1½"	1400	1000	800	700	300	400	70
EN SM P1E 4T55 10/330+S18/100	4	2	50	S18/100	1,5	2	DN80 - F50	CM50 - V50	2"	1½"	1400	1000	800	700	300	400	70
EN SM P1E 6TA75 12/330+S23/60	5,5	3	50	S23/60	1,1	2	DN80 - F50	CM50 - V50	2"	1½"	1400	1000	800	700	300	400	70
EN SM P1E 4T55 6/400+S15/60	4	2	50	S15/60	0,75	2	DN80 - F50	CM50 - V50	3"	1½"	1400	1000	800	700	300	400	70
EN SM P1E 6TA75 7/400+S18/100	5,5	3	50	S18/100	1,5	2	DN80 - F50	CM50 - V50	3"	1½"	1400	1000	800	700	300	400	70
EN SM P1E 6TA10 8/400+S18/100	7,5	3	50	S18/100	1,5	2	DN80 - F50	CM50 - V50	3"	1½"	1400	1000	800	700	300	400	70
EN SM P1E 6TA10 10/400+S23/60	7,5	3	50	S23/60	1,1	2	DN80 - F50	CM50 - V50	3"	1½"	1400	1000	800	700	300	400	70
EN SM P1E 6TA75 5/700+S15/60	5,5	3	50	S15/60	0,75	2	DN80 - F50	CM50 - V50	3"	1½"	1400	1000	800	700	300	400	70
EN SM P1E 6TA10 6/700+S18/100	7,5	3	50	S18/100	1,5	2	DN80 - F50	CM50 - V50	3"	1½"	1400	1000	800	700	300	400	70
EN SM P1E 6TA125 8/700+S23/60	9,2	3	50	S23/60	1,1	2	DN80 - F50	CM50 - V50	3"	1½"	1400	1000	800	700	300	400	70
EN SM P1E 6TA15 10/700+S27/100	11	3	50	S27/100	2,2	2	DN80 - F50	CM50 - V50	3"	1½"	1400	1000	800	700	300	400	70
EN SM P1E 6TA125 5/900+S15/60	9,2	3	65	S15/60	0,75	2	DN80 - F50	CM65 - V50	3"	1½"	1400	1000	800	700	300	400	70
EN SM P1E 6TA15 6/900+S18/100	11	3	65	S18/100	1,5	2	DN80 - F50	CM65 - V50	3"	1½"	1400	1000	800	700	300	400	70
EN SM P1E 6TA20 8/900+S23/60	15	3	65	S23/60	1,1	2	DN80 - F50	CM65 - V50	3"	1½"	1400	1000	900	700	350	450	120
EN SM P1E 6TA15 3/1500+S12/60	11	3	65	S12/60	0,55	2	DN80 - F50	CM65 - V50	4"	1½"	1400	1000	800	700	300	400	70
EN SM P1E 6TA20 4/1500+S15/60	15	3	65	S15/60	0,75	2	DN80 - F50	CM65 - V50	4"	1½"	1400	1000	900	700	350	450	120
EN SM P1E 6TA25 5/1500+S18/100	18,5	3	65	S18/100	1,5	2	DN80 - F50	CM65 - V50	4"	1½"	1400	1000	900	700	350	450	120
EN SM P1E 6TA30 6/1500+S23/60	22	3	65	S23/60	1,1	2	DN80 - F50	CM65 - V50	4"	1½"	1400	1000	900	700	350	450	120
EN SM P1E E8S55/3A+S30/11	15	1,5	100	S30/11	0,75	1,5	DN100 - F65	CM80 - V65	100	1¼"	1400	1000	900	700	350	450	120
EN SM P1E E8S55/4A+S30/16	18,5	1,5	100	S30/16	1,1	1,5	DN100 - F65	CM80 - V65	100	1¼"	1400	1000	900	700	350	450	120
EN SM P1E E8S55/5A+S30/16	22	1,5	100	S30/16	1,1	1,5	DN100 - F65	CM80 - V65	100	1¼"	1400	1000	900	700	350	450	120
EN SM P1E E8S55/5A+S30/16	26	1,5	100	S30/16	1,1	1,5	DN100 - F65	CM80 - V65	100	1¼"	1400	1000	900	700	350	450	120
EN SM P1E E8S64/3A+S30/11	22	1,5	100	S30/11	0,75	1,5	DN100 - F65	CM80 - V65	125	1¼"	1400	1000	900	700	350	450	120
EN SM P1E E8S64/4K+S30/16	26	1,5	100	S30/16	1,1	1,5	DN100 - F65	CM80 - V65	125	1¼"	1400	1000	900	700	350	450	120
EN SM P1E E8S64/4A+S30/16	30	1,5	100	S30/16	1,1	1,5	DN100 - F65	CM80 - V65	125	1¼"	1400	1000	900	700	350	450	120

IDROFIRE SM P2E

N.1 ELETTROPOMPA DI SERVIZIO + N.1 ELETTROPOMPA DI RISERVA + PILOTA
 NR.1 MAIN ELECTRIC PUMP + NR.1 BACKUP ELECTRIC PUMP + JOCKEY PUMP

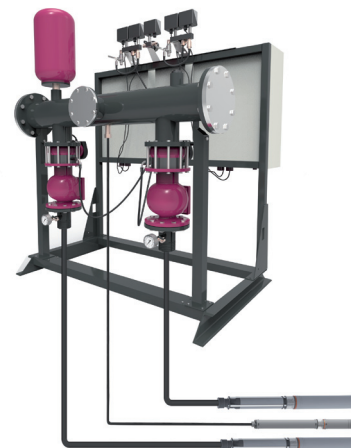

ELENCO COMPONENTI COMPONENT LIST

- | | |
|---|--|
| <ol style="list-style-type: none"> 1. Elettropompa di servizio Sommersa 2. Elettropompa di riserva Sommersa 3. Elettropompa Pilota Sommersa 4. Valvola di ritegno a clapet 5. Valvola di intercettazione lucchettabile 6. Valvola di ritegno 7. Valvola di intercettazione a sfera con leva 8. Collettore di mandata reversibile completo di flangia cieca 9. Derivazione per collettore di prova di portata 10. Predisposizione per kit sprinkler 11. Kit avviamento per pompe principali composto da 2 pressostati 2-14 bar con pulsante di prova integrato, 1 manometro 0-16 bar e circuito by-pass 12. Kit avviamento per pompa pilota composto da 1 pressostato con pulsante di prova integrato, 1 manometro 13. Quadri elettrici di comando (uno per ogni pompa) 14. Kit diaframma di ricircolo completo di indicatore visivo di flusso 15. Manometro 0-16 bar 16. Serbatoio Autoclave 24 lt PN16 17. Telaio | <ol style="list-style-type: none"> 1. Main submersible electric pump 2. Backup submersible electric pump 3. Jockey submersible electric pump 4. Swing Check Valve ("Clapet" Valve) 5. Shut-off valve lockable 6. Check valve 7. Ball valve with level 8. Reversible delivery manifold with blind flange 9. Shunt for flow meter 10. Predisposition for sprinkler kit 11. Starting kit for main pump composed by 2 pressure switch 2-14 bar with integrated test button, 1 pressure gauge 0-16 bar and by-pass circuit 12. Starting kit for jockey electric pump composed by 1 pressure switch with integrated test button, 1 pressure gauge 13. Electrical control panels (one for each pump) 14. Kit recycling diaphragm complete with visual flow indicator 15. Pressure gauge 0-16 bar 16. Diaphragm pressure vessel 24LT PN16 17. Frame |
|---|--|

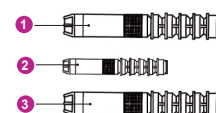
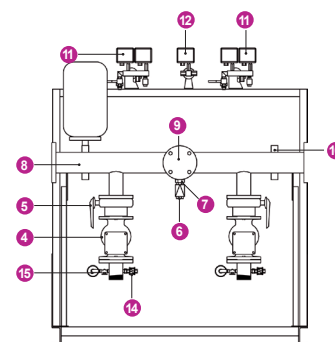
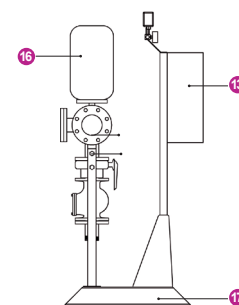

IDROFIRE SM P2E

DIMENSIONI DIMENSIONS

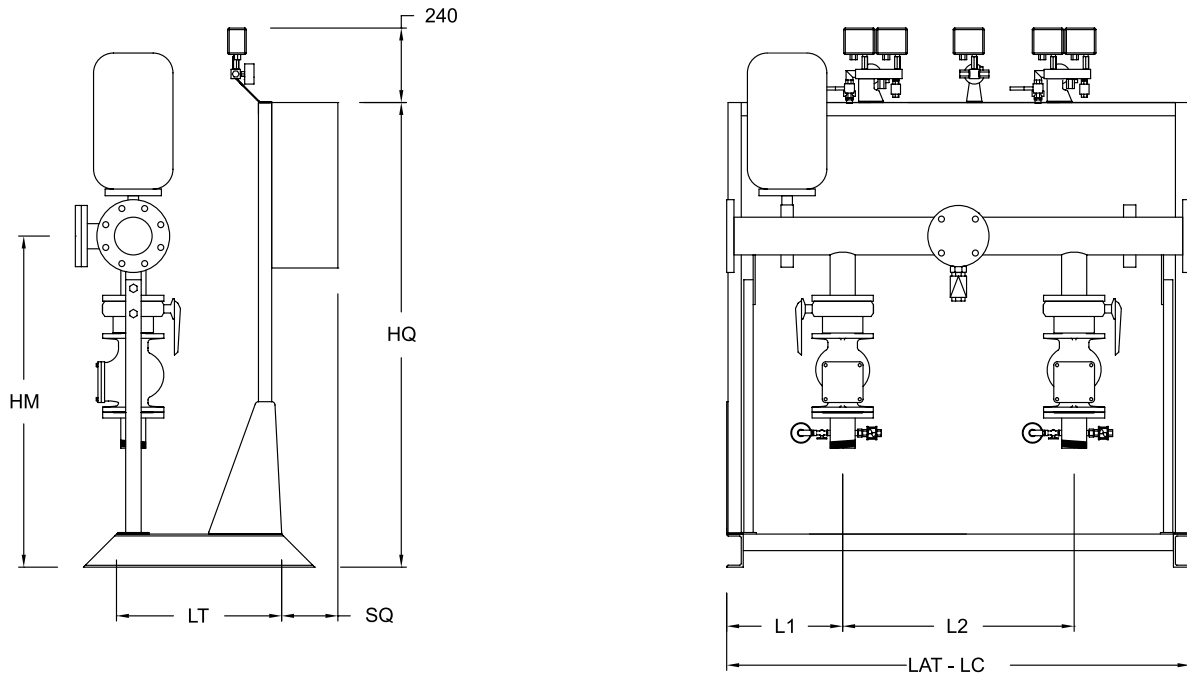

DATI TECNICI TECHNICAL DATA

MODELLO GRUPPO MODEL GROUP	POMPA PRINCIPALE MAIN PUMP			POMPA PILOTA el. engine			COLLETTORE DI MANDATA DELIVERY MANIFOLD	KIT FLUSSIMETRO FLOW METER KIT	DIMENSIONI MM DIMENSION MM									
	kW	mod.	DN	mod.	kW	m			bocca1	bocca2	Hq	Hm	LaT-Lc	Lt	L1	L2	Lf	Sq
EN SM P2E 4T20 6/230+S12/60	1,5	2	50	S12/60	0,55	2	DN80 - F50	CM50 - V50	2"	1½"	1400	1000	1200	700	300	600	600	70
EN SM P2E 4TH30 9/230+S15/60	2,2	2	50	S15/60	0,75	2	DN80 - F50	CM50 - V50	2"	1½"	1400	1000	1200	700	300	600	600	70
EN SM P2E 4T40 11/230+S18/100	3	2	50	S18/100	1,5	2	DN80 - F50	CM50 - V50	2"	1½"	1400	1000	1200	700	300	600	600	70
EN SM P2E 4T40 7/330+S15/60	3	2	50	S15/60	0,75	2	DN80 - F50	CM50 - V50	2"	1½"	1400	1000	1200	700	300	600	600	70
EN SM P2E 4T55 9/330+S18/100	4	2	50	S18/100	1,5	2	DN80 - F50	CM50 - V50	2"	1½"	1400	1000	1200	700	300	600	600	70
EN SM P2E 4T55 10/330+S18/100	4	2	50	S18/100	1,5	2	DN80 - F50	CM50 - V50	2"	1½"	1400	1000	1200	700	300	600	600	70
EN SM P2E 6TA75 12/330+S23/60	5,5	3	50	S23/60	1,1	2	DN80 - F50	CM50 - V50	2"	1½"	1400	1000	1200	700	300	600	600	70
EN SM P2E 4T55 6/400+S15/60	4	2	50	S15/60	0,75	2	DN80 - F50	CM50 - V50	3"	1½"	1400	1000	1200	700	300	600	600	70
EN SM P2E 6TA75 7/400+S18/100	5,5	3	50	S18/100	1,5	2	DN80 - F50	CM50 - V50	3"	1½"	1400	1000	1200	700	300	600	600	70
EN SM P2E 6TA10 8/400+S18/100	7,5	3	50	S18/100	1,5	2	DN80 - F50	CM50 - V50	3"	1½"	1400	1000	1200	700	300	600	600	70
EN SM P2E 6TA10 10/400+S23/60	7,5	3	50	S23/60	1,1	2	DN80 - F50	CM50 - V50	3"	1½"	1400	1000	1200	700	300	600	600	70
EN SM P2E 6TA75 5/700+S15/60	5,5	3	50	S15/60	0,75	2	DN80 - F50	CM50 - V50	3"	1½"	1400	1000	1200	700	300	600	600	70
EN SM P2E 6TA10 6/700+S18/100	7,5	3	50	S18/100	1,5	2	DN80 - F50	CM50 - V50	3"	1½"	1400	1000	1200	700	300	600	600	70
EN SM P2E 6TA125 8/700+S23/60	9,2	3	50	S23/60	1,1	2	DN80 - F50	CM50 - V50	3"	1½"	1400	1000	1200	700	300	600	600	70
EN SM P2E 6TA15 10/700+S27/100	11	3	50	S27/100	2,2	2	DN80 - F50	CM50 - V50	3"	1½"	1400	1000	1200	700	300	600	600	70
EN SM P2E 6TA125 5/900+S15/60	9,2	3	65	S15/60	0,75	2	DN80 - F50	CM65 - V50	3"	1½"	1400	1000	1200	700	300	600	600	70
EN SM P2E 6TA15 6/900+S18/100	11	3	65	S18/100	1,5	2	DN80 - F50	CM65 - V50	3"	1½"	1400	1000	1200	700	300	600	600	70
EN SM P2E 6TA20 8/900+S23/60	15	3	65	S23/60	1,1	2	DN80 - F50	CM65 - V50	3"	1½"	1400	1000	1400	700	350	700	700	120
EN SM P2E 6TA15 3/1500+S12/60	11	3	65	S12/60	0,55	2	DN80 - F50	CM65 - V50	4"	1½"	1400	1000	1200	700	300	600	600	70
EN SM P2E 6TA20 4/1500+S15/60	15	3	65	S15/60	0,75	2	DN80 - F50	CM65 - V50	4"	1½"	1400	1000	1400	700	350	700	700	120
EN SM P2E 6TA25 5/1500+S18/100	18,5	3	65	S18/100	1,5	2	DN80 - F50	CM65 - V50	4"	1½"	1400	1000	1400	700	350	700	700	120
EN SM P2E 6TA30 6/1500+S23/60	22	3	65	S23/60	1,1	2	DN80 - F50	CM65 - V50	4"	1½"	1400	1000	1400	700	350	700	700	120
EN SM P1E E8S55/3A+S30/11	15	1,5	100	S30/11	0,75	1,5	DN125 - F80	CM80 - V80	100	1¼"	1400	1000	1400	700	350	700	700	120
EN SM P1E E8S55/4A+S30/16	18,5	1,5	100	S30/16	1,1	1,5	DN125 - F80	CM80 - V80	100	1¼"	1400	1000	1400	700	350	700	700	120
EN SM P1E E8S55/5A+S30/16	22	1,5	100	S30/16	1,1	1,5	DN125 - F80	CM80 - V80	100	1¼"	1400	1000	1400	700	350	700	700	120
EN SM P1E E8S55/5A+S30/16	26	1,5	100	S30/16	1,1	1,5	DN125 - F80	CM80 - V80	100	1¼"	1400	1000	1400	700	350	700	700	120
EN SM P1E E8S64/3A+S30/11	22	1,5	100	S30/11	0,75	1,5	DN125 - F80	CM80 - V80	125	1¼"	1400	1000	1400	700	350	700	700	120
EN SM P1E E8S64/4K+S30/16	26	1,5	100	S30/16	1,1	1,5	DN125 - F80	CM80 - V80	125	1¼"	1400	1000	1400	700	350	700	700	120
EN SM P1E E8S64/4A+S30/16	30	1,5	100	S30/16	1,1	1,5	DN125 - F80	CM80 - V80	125	1¼"	1400	1000	1400	700	350	700	700	120



ACCESSORI

GAMMA BG - VTS - SM

ACCESSORIES

BG - VTS - SM RANGE

KIT FLUSSIMETRO

Il kit comprende:

- Flussimetro di derivazione a lettura rinviata.
Può essere installato sia in posizione verticale che orizzontale e va dimensionato in base alla portata massima dell'impianto.
- Collettore costruito in acciaio zincato con la funzione di un circuito dove convogliare l'acqua per effettuare la misurazione della portata. Va installato nell'apposita derivazione posta al centro del collettore di mandata
- Valvola di intercettazione lucchettabile tipo LUG posizionata tra il collettore e l'apposita derivazione del gruppo antincendio.



FLOWMETER KIT

The kit is composed by:

- Derivation flowmeter. It can be installed either horizontally or vertically.
It has to be dimensioned according to the maximum of the system
- The manifold is made of galvanized steel. It has the function to convey the water to the flowmeter to measure the capacity.
It has to be installed in the centre of the delivery manifold.
- LUG Lockable ball valve between the manifold and the appropriate derivation flange of the fire fighting unit



QUADRO DI ALLARME AUTOALIMENTATO CON BATTERIA A TAMPONE MOD. UNIT ALARM-EN

Quadro riporto allarmi da installare all'interno del locale di controllo degli sprinkler o nel locale pompe. Autoalimentato con batteria a tampone, segnala a distanza l'avviamento ed eventuali anomalie del gruppo. Obbligatorio come da norma EN12845.

SELF-POWERED CONTROL ALARM PANEL WITH BUFFER BATTERY MOD. UNIT ALARM-EN

Control alarm panel to be installed inside the sprinklers checking room or pumps room. It is self-powered with buffer battery and it has the remote start and default signals. It is mandatory as per EN12845 norm.



SIRENA ACUSTICO-LUMINOSA

Sirena acustico-luminosa da 90 dB. Come specifica la norma gli allarmi, devono essere trasmessi ad una postazione permanentemente presidiata, dentro o fuori dal fabbricato oppure ad una persona responsabile in modo tale che possa essere intrapresa immediatamente un'azione appropriata.

BEACON AND FLASHING ALARM

Beacon and flashing alarm 90 dB. As requested by the norm the alarms must be sent to a permanent overseen place, inside or outside the building or to a responsible person. Therefore the most appropriate action can be undertaken immediately.



GSM - MOD. MIKROS GSM

Combinatore telefonico GSM Dual Band multifunzione, particolarmente adatto a molteplici altre applicazioni quali l'attivazione da remoto di apparati elettrici in genere, così come la trasmissione di avvisi vocali, SMS o digitali di eventi tecnici o di allarme quali incendio, limiti di temperatura, assenza rete elettrica, soccorso ecc. ti avvisa con messaggi vocali, SMS o digitali.

GSM - MOD. MIKROS GSM

Automatic phone dialler GSM Dual Band multifunction,.

It is suitable for several other applications such as electrical devices remote start, SMS, vocal, digital alerts transmissions of technical information or alarms such us fire, temperature limits, electrical mains absence, assistance etc.



KIT SPRINKLER

- Sprinkler
 - Valvola di prova flussostato per verificare il funzionamento di esso
 - Scarico valvola di prova da scaricare singolarmente all'esterno o in vasca
 - Flussostato a paletta
- Adibito per la protezione del locale pompe in caso di incendio.

SPRINKLER KIT

- Sprinkler.
 - Water flow switch to check the functioning
 - Discharge test valve into the tank
 - Flow switch
- It is for the protection of the pumps room in case of fire
 Technical information or alarms such us fire, temperature limits, electrical mains absence, assistance etc.



GIUNTO DI COMPENSAZIONE

- Disponibile in tre diverse tipologie.
- Giunto in gomma di compensazione flangiato (obbligatorio in caso di motopompa).
 - Giunto in acciaio INOX.

RUBBER JOINT

- It is available in 3 different types:
- Flanged rubber joint (this is mandatory in case of motorpump)
 - Galvanized steel joint

ACCESSORI PER MOTOPOMPA

GAMMA BG - VTS

ACCESSORIES FOR MOTORPUMP

BG - VTS RANGE



KIT RICAMBI MOTORE DIESEL

Set kit manutenzione per motore diesel per 2 anni.

DIESEL ENGINE SPARE PART KIT

Maintenance kit for diesel engine for 2 years



SCAMBIATORE DI CALORE ACQUA-ACQUA PER MOTORI DIESEL RAFFREDDATI A LIQUIDO

Accessorio che viene applicato a motori diesel raffreddati a liquido, viene installato in sostituzione del radiatore tradizionale per facilitare e evitare la presenza di un convogliatore d'aria.

HEAT EXCHANGER FOR LIQUID COOLED DIESEL ENGINE

This is installed in stead of the standard cooler in order to avoid the presence of an air conveyor



VALVOLA DI SFIORO DI PRESSIONE

Valvola di sicurezza tarabile utilizzata per scaricare l'eccesso di pressione.

PRESSURE VENT VALVE

Adjustable safety valve to discharge the overpressure.

ACCESSORI PER ASPIRAZIONE POMPE

GAMMA BG

ACCESSORIES FOR SUCTION PUMP

BG RANGE

ACCESSORI PER GRUPPI INSTALLATI SOTTOBATTENTE

ACCESSORIES FOR BELOW HEAD SUCTION PUMP



KIT ASPIRAZIONE POMPE SOTTOBATTENTI

Come specificato nella norma EN12845, sull'aspirazione di ogni pompa che lavori sottobattente è obbligatorio installare:

- Una riduzione eccentrica bi flangiata in acciaio zincato per maggiorazione della sezione dell'impianto di aspirazione per far sì che l'acqua scorra ad una velocità Max di 1,8 m/sec.
- Una valvola a farfalla tipo LUG del DN maggiorato della riduzione eccentrica
- Valvola a sfera con giunto 3 pezzi (per pompa pilota).

ASPIRATION KIT FOR BELOW SUCTION PUMPS

As required in the norm EN12845, on the aspiration of each below suction pump, the below accessories are mandatory:

- Eccentric double flanged galvanized steel reduction to increase the diameter of the aspiration system piping in order to let the water flow with a maximum speed of 1,8 m/sec.
- LUG butterfly valve with the DN bigger than the one of the eccentric reduction.
- Ball valve with 3 pieces joint (for jockey pump)

ACCESSORI PER GRUPPI INSTALLATI SOPRABATTENTE

ACCESSORIES FOR ABOVE HEAD SUCTION PUMP

SERBATOIO DI ADESCAMENTO (n.1 per ogni pompa principale)

Serbatoio della capacità di 100 o 500 lt a seconda della classificazione di rischio dello stabilimento (par. 10.6.2.3 norma EN12845), costruito in polietilene lineare con la funzione di adescare le pompe quando il gruppo è installato soprabattente. Viene fornito provvisto di raccordi, valvole e tubazioni per consentirne il corretto funzionamento.

Per le versioni P1E (1 elettropompa+pilota) e P1M (1 motopompa+pilota), esiste la possibilità di installare il serbatoio a bordo macchina mediante un supporto in acciaio zincato applicato direttamente sul telaio.

In tal caso il collegamento del serbatoio con le pompe verrà effettuato c/o nostro stabilimento.

PRIMINING TANK (1 for each main pump)

100 or 500 lt tank according to the building classification of risk (par. 10.6.2.3 norma EN12845) with the function to prime the pump. It is made of linear polyethylene and is complete with connections, valves and piping to make it work properly. For the P1E (1electro pump + jockey) and P1M (1motor pump + jockey), the tank can also be installed on board through a galvanized steel support based on the frame. In this case the connection between the tank and the pump will be made in our premises.

- Ball valve with 3 pieces joint (for jockey pump)

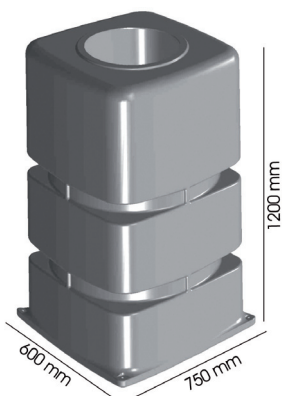

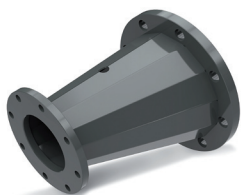

RIDUZIONE ECCENTRICA BIFLANGIATA

Come specificato nella norma EN12845, sull'aspirazione di ogni pompa che lavori soprabattente è obbligatorio installare:

- Una riduzione eccentrica biflangiata in acciaio zincato con pendenza max di 20° per aumentare la sezione dell'impianto di aspirazione per far sì che l'acqua scorra ad una velocità Max di 1,5 m/sec.

ECCENTRIC DOUBLE FLANGED REDUCTION

As required in the norm EN12845, on the aspiration of each above suction pump, the below accessories are mandatory:

- Eccentric double flanged galvanized steel reduction with a max slope of 20° to increase the diameter of the aspiration system piping in order to let the water flow with a maximum speed of 1,5 m/sec.



KIT ASPIRAZIONE POMPE SOTTOBATTENTI

- Una valvola di fondo con succheruola flangiata del DN maggiorato della riduzione eccentrica per pompe principali
- Una valvola di fondo con filtro, filettata per pompa pilota (opzionale)

ASPIRATION KIT FOR BELOW HEAD SUCTION PUMPS

- Flanged foot valve with strainer with a DN bigger than the one of the eccentric reduction of the main pumps
- Threaded foot valve with filter for jockey pump (optional)

ACCESSORI

GAMMA SM

ACCESSORIES

SM RANGE

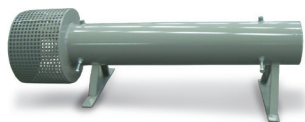

CAMICIA DI RAFFREDDAMENTO PER ELETTROPOMPA SOMMERSA

Composto da un tubo in acciaio zincato con dadi di centraggio e filtro per evitare l'aspirazione di scorie.

La tubazione è tenuta in obliquo grazie a dei supporti di diversa altezza e con predisposti due fori per il fissaggio della camicia sul fondo del serbatoio. Consigliato per elettropompe sommerse.

COOLING CHAMBER FOR SUBMERSIBLE ELECTRO PUMP

It is composed by a galvanized steel pipe with centring pins and filter to avoid the aspiration of slag.

The piping is oblique thanks to supports of different height and it has 2 locks to fix the chamber at the bottom of the tank. It is advisable for submersible electro pump.



SUPPORTO AD ANELLO PER ELETTROPOMPA SOMMERSA

Costruiti con anelli di larghezza 5 cm in acciaio zincato, con saldati 3 dadi per permettere il centraggio delle pompe.

Vengono utilizzati per elettropompe sommerse in caso di installazione orizzontale, al contrario della camicia di raffreddamento viene utilizzato solo come supporto.

RING SUPPORTS FOR SUBMERSIBLE ELECTRO PUMP

The 5 cm galvanized steel rings have 3 welded nuts to centre the pumps. They are used for the submersible electro pump with horizontal installation only like supports.

INFORMAZIONI TECNICHE

ASPIRAZIONE POMPE GAMMA BG

TECHNICAL INFORMATION

BG RANGE PUMP SUCTION

INSTALLAZIONE SOTTOBATTENTE

Rif. Accessorio - Kit aspirazione sottobattente mod. P (DN) - S (DN1)
(Giunto di compensazione obbligatorio solo in caso di motopompa)

BELOW HEAD INSTALLATION

Rif. Accessory - aspiration kit below head suction pump mod. P (DN) - S (DN1)
(Flanged rubber joint mandatory only in case of motor pump)

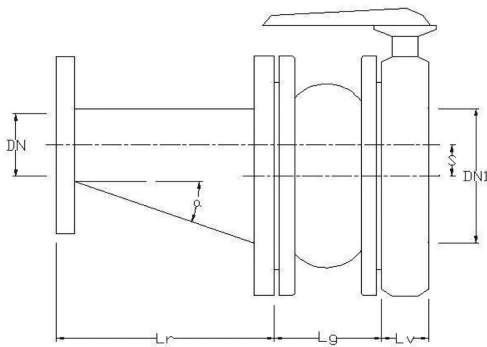

INSTALLAZIONE SOPRABATTENTE

Rif. Accessorio - Riduzione eccentrica mod. DN x DN1
(Giunto di compensazione obbligatorio solo in caso di motopompa)

ABOVEHEAD INSTALLATION

Rif. Accessory - eccentric double flanged mod. DN x DN1
(Eccentric double wall reduction mandatory only in case of motor pump)

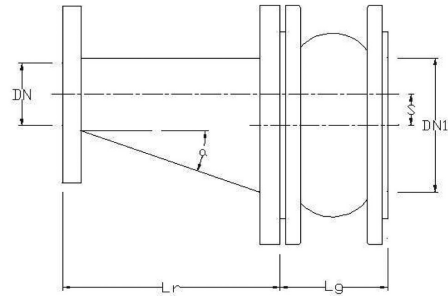

DATI TECNICI TECHNICAL DATA

DN	DN1	Lr	Lg	Lv	s
50	65	155	115	46	7,5
50	80	160	130	46	15
50	100	190	135	52	27,5
65	80	190	130	46	7,5
65	100	220	135	52	20
65	125	220	170	56	32,5
65	150	315	180	56	49
80	100	225	135	52	12,5
80	125	225	170	56	25
80	150	265	180	56	40
80	200	405	205	60	65
80	250	562	245	68	94,5
100	150	250	180	56	25,5
100	200	340	205	60	52,5
100	250	495	245	68	80
125	200	300	205	60	40
125	250	440	245	68	67,5
125	300	565	260	78	92,5
125	350	680	265	78	112,5
150	200	350	205	60	27,5
150	250	360	245	68	52,5
150	300	485	260	78	77,5
150	350	600	265	78	97,5
150	400	765	265	102	127,5
200	300	460	260	78	55
200	350	480	265	78	75
200	400	630	265	102	102,5
200	450	740	265	114	122,5
250	350	570	265	78	40
250	400	570	265	102	72,5
250	450	580	265	114	92,5

LEGENDA LEGEND

a: angolo massimo 20° come da par.10.6.2.1 della UNI EN 12845:2009

Tolleranze Lunghezza: +/- 5 mm

Tolleranze: +/- 5 mm

DN: Diametro Aspirazione lato pompa

DN1: Diametro Aspirazione dimensionato come da norma EN12845 par. 10.6.2

Lr: Lunghezza riduzione eccentrica

Lg: Lunghezza giunto di compensazione

Lv: Lunghezza Valvola di intercettazione

s: disassamento

a: maximum 20° as per par.10.6.2.1 of the UNI EN 12845:2009

Lenght tolerances : +/- 5 mm

TS tolerances : +/- 5 mm

DN: Diameter aspiration pump side

DN1: Aspiration diameter dimensioned according to EN12845 par. 10.6.2

Lr: Eccentric double flanged reduction lenght

Lg: Flanged rubber joint lenght

Lv: Ball valve lenght

s: offset

INFORMAZIONI TECNICHE

TIPO DI INSTALLAZIONE

TECHNICAL INFORMATION

INSTALLATION TYPE

INSTALLAZIONE SOTTOBATTENTE

- DN minimo 65 (par. 10.6.2.2 - EN12845)
- Velocità acqua 1.8 m/s (par. 10.6.2.2 - EN12845)
- Nel caso di serbatoi aperti applicare un filtro all'esterno del serbatoio.
- Tra serbatoio e filtro installare una valvola d'intercettazione (par. 9.3.6 - EN12845)
- Aspirazioni interconnesse con valvole d'intercettazione (par. 10.6.2.2 - EN12845)

BELOWHEAD INSTALLATION

- Minimum DN 65DN (par. 10.6.2.2 - EN12845)
- Water speediness 1.8 m/s (par. 10.6.2.2 - EN12845)
- In case of open tank, you should put an external filter outside the tank
- An intercept valve has to be installed between the tank and the filter
- Interconnected aspirations with intercept valves (par. 10.6.2.2 - EN12845)

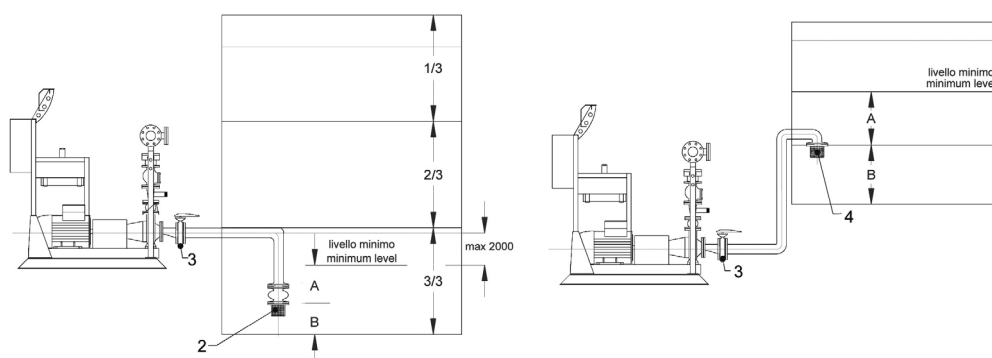

INSTALLAZIONE SOPRABATTENTE

- DN minimo 80 (par. 10.6.2.3 - EN12845)
- Velocità acqua 1.5 m/s (par. 10.6.2.3 - EN12845)
- In aspirazione applicare una valvola di fondo con a monte un filtro da poter pulire senza svuotare il serbatoio (par. 9.3.6 - EN12845)
- Aspirazioni singole per ogni pompa (par. 10.6.2.3 - EN12845)
- Ogni pompa deve essere dotata di un serbatoio di adescamento automatico (par. 10.6.2.4 - EN12845)

ABOVEHEAD INSTALLATION

- Minimum DN 80 (par. 10.6.2.3 - EN12845)
- Water speediness 1.5 m/s (par. 10.6.2.3 - EN12845)
- Aspiration shut-down valve with a filter installed at the end of it. It has to be possible to clean the filter without empty the tank (par. 9.3.6 - EN12845)
- Single aspiration for each pump (par. 10.6.2.3 - EN12845)
- Each pump has to be equipped with a priming automatic tank (par. 10.6.2.4 - EN12845)

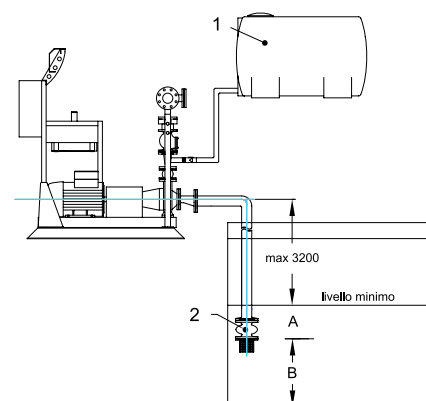

DATI TECNICI TECHNICAL DATA

Ø nominale tubo di aspirazione	h A minimo	h B minimo	Dim. minima piastra antivortice
Nominal Ø aspiration pipe	Minimum h A	Minimum h B	Minimum dimensions for the anivortex plate
mm	m	m	m
65	65	0.08	0.20
80	80	0.08	0.20
100	100	0.10	0.40
150	150	0.10	0.60
200	200	0.15	0.80
250	250	0.20	1.00
300	300	0.20	1.20
400	400	0.30	1.20
500	500	0.35	1.20

Classe di pericolo	Capacità min. del serbatoio	Ø tubazione minima
Hazard Class	Minimum tank capacity	Minimum pipe Ø
	lt	mm
LH	100	25
OH-HHP-HHS	500	50

LEGENDA LEGEND

- 1: serbatoio adescamento
 - 2: valvola di fondo con filtro
 - 3: valvola d'intercettazione
 - 4: filtro
- A: distanza tra livello min.ed aspirazione
 B: distanza dall'aspirazione al fondo.
 Se applicata una piastra antivortice a=0.1 m (par. 9.3.5 - EN12845)
- 1: priming tank
 - 2: shut-down valve with filter
 - 3: intercept valve
 - 4: filter
- A: distance between aspiration and min. level
 B: Distance between aspiration and bottom.
 In case there is the antivortex plate a=0.1 m (par. 9.3.5 - EN12845)

INFORMAZIONI TECNICHE

SCHEMI IDRAULICI

TECHNICAL INFORMATION

HYDRAULIC DIAGRAMS

● SCHEMA MONTAGGIO GRUPPO ANTINCENDIO EN12845 INSTALLAZIONE SOTTOBATTENTE FIRE FIGHTING UNIT ASSEMBLY DIAGRAM EN12845 UNDER HEAD SUCTION INSTALLATION

1 POMPA 1 PUMP

2 POMPE 2 PUMPS

-  VALVOLA DI CHIUSURA CLOSING VALVE
-  MANOMETRO MANOMETER
-  MANOVUOTOMETRO VACUUM GAUGES
-  VALVOLA NON RITORNO CHEK VALVE
-  PRESSOSTATO PRESSURE SWITCH
-  DIAFRAMMA DI RICIRCOLO RECYCLE DIAPHRAGM
-  VASO ESPANSIONE EXPANSION VESSEL

-  POMPA PUMP
-  MISURATORE DI PORTATE FLOW METER
-  ATTACCO 1" PER SPRINKLER 1" SPRINKLER CONNECTION
-  FLUSSOSTATO FLOW SWITCH
-  ANELLO ANTINCENDIO FIRE RING
-  RIDUZIONE ECCENTRICA REDUCTION ECCENTRIC

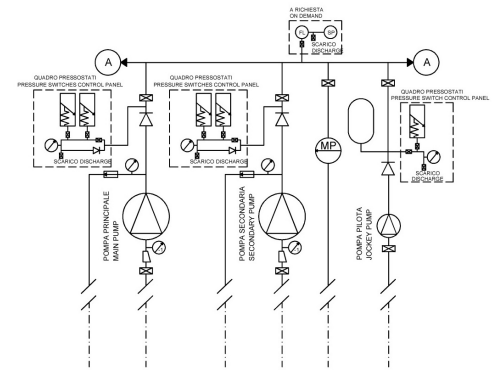
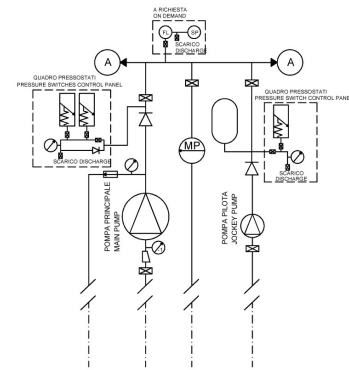

● SCHEMA MONTAGGIO GRUPPO ANTINCENDIO EN12845 INSTALLAZIONE SOPRABATTENTE FIRE FIGHTING UNIT ASSEMBLY DIAGRAM EN12845 OVER HEAD SUCTION INSTALLATION

1 POMPA 1 PUMP

2 POMPE 2 PUMPS

-  VALVOLA DI CHIUSURA CLOSING VALVE
-  MANOMETRO MANOMETER
-  MANOVUOTOMETRO VACUUM GAUGES
-  VALVOLA NON RITORNO CHEK VALVE
-  PRESSOSTATO PRESSURE SWITCH
-  DIAFRAMMA DI RICIRCOLO RECYCLE DIAPHRAGM
-  VASO ESPANSIONE EXPANSION VESSEL

-  MISURATORE DI PORTATE FLOW METER
-  ATTACCO 1" PER SPRINKLER 1" SPRINKLER CONNECTION
-  FLUSSOSTATO FLOW SWITCH
-  ANELLO ANTINCENDIO FIRE RING
-  RIDUZIONE ECCENTRICA REDUCTION ECCENTRIC
-  CISTERNA ADESCAMENTO PRIMING TANK
-  INTERRUITTORE DI LIVELLO LEVEL SWITCH
-  TROPPO PIENO OVERFLOW
-  SCARICO DISCHARGE
-  GALLEGGIANTE DI RIEMPIMENTO FILLING FLOATER

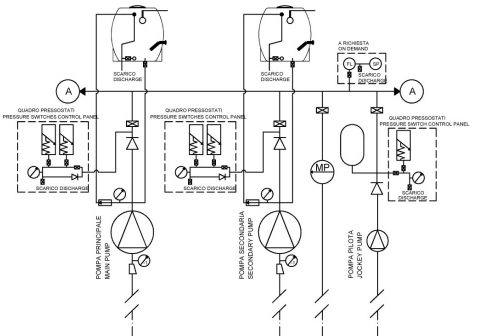
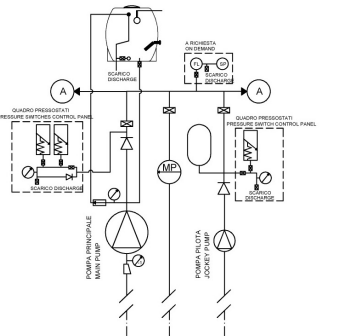





● SCHEMA MONTAGGIO GRUPPO ANTINCENDIO EN12845 CON POMPE SOMMERSE FIRE FIGHTING UNIT ASSEMBLY DIAGRAM EN12845 WITH SUBMERGED PUMP

1 POMPA 1 PUMP

2 POMPE 2 PUMPS

-  VALVOLA DI CHIUSURA CLOSING VALVE
-  MANOMETRO MANOMETER
-  VALVOLA NON RITORNO CHEK VALVE
-  PRESSOSTATO PRESSURE SWITCH
-  DIAFRAMMA DI RICIRCOLO RECYCLE DIAPHRAGM
-  VASO ESPANSIONE EXPANSION VESSEL

-  POMPA PUMP
-  MISURATORE DI PORTATE FLOW METER
-  ATTACCO 1" PER SPRINKLER 1" SPRINKLER CONNECTION
-  FLUSSOSTATO FLOW SWITCH
-  ANELLO ANTINCENDIO FIRE RING

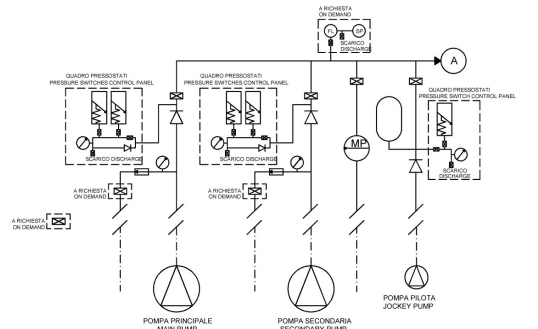
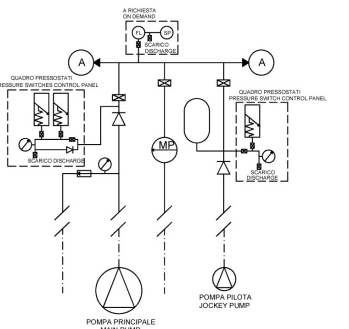

COMPONENTI PER IMPIANTI COMPONENTS FOR INSTALLATION

IMPIANTI AD IDRANTI HYDRANT INSTALLATIONS



Naspi DN25.
DN25 Fire hose.



Idranti DN45 a muro da interno e da esterno.
DN45 Internal and external Fire Hydrants.



Idranti soprasuolo DN70.
DN70 Overground hydrants.



Cassetta corredo idrante soprasuolo DN70.
DN70 Hose rack cabinet for overground hydrants.



Gruppi attacco autopompa di mandata.
Delivery coupling units.



Armadio corredo idrante sottosuolo.
Cabinets for underground hydrant.



Idranti sottosuolo con attacco baionetta o filettato.
Underground hydrants with bayonet coupling or threaded end.

IMPIANTI SPRINKLER SPRINKLERS INSTALLATIONS



Valvole di allarme Sprinkler ad umido assemblate.
Wet alarm sprinkler valve assembly.



Valvole di allarme Sprinkler a secco assemblate.
Dry alarm valve sprinkler assembly.



Valvole di allarme Sprinkler a diluio ad attuazione elettrica assemblate.
Deluge alarm valve sprinkler assembly.

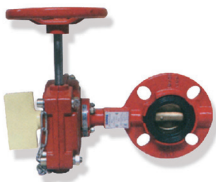

Valvole a farfalla PN10/16 - ANSI 125.
PN10/16 - ANSI 125 Butterfly valves.



Saracinesche a vite esterna UL/FM.
UL/FM Gate valves, outside screw.



Valvole di sicurezza UL/FM.
UL/FM Reliev valves.



Sprinkler Upright DN 15 K=80 1/2" NPT.
Upright DN 15 K=80 1/2" NPT Sprinklers.



Sprinkler per magazzini - ESFR.
Storage sprinklers - ESFR.



Sprinkler orizzontali.
Horizontal sprinklers.



Ugello nebulizzatore.
Atomizer nozzles.

IMPIANTI A SCHIUMA FOAM INSTALLATIONS



Gruppi mobili a schiuma.
Mobile foam groups.



Miscelatore variabile da 1% a 6%.
Miscelatore variabile da 1% a 6%.



Lancia schiuma media espansione.
Foam nozzles, medium expansion.



Lance schiuma bassa espansione.
Foam nozzles, low expansion.

Nella catalogo specifico **LOCALI E SISTEMI** illustreremo tutte le nostre soluzioni per ciò che riguarda sia l'alloggiamento dei gruppi antincendio all'interno dei locali tecnici che le riserve idriche.

In the other catalogue we show all our solutions for the fire fighting unit rooms and for the water storages.

LA GAMMA COMPLETA COMPLETE RANGE



UNISHELT: Locale tecnico da ESTERNO a norma UNI11292 per alloggio gruppi pompe della gamma BG.
UNISHELT: External room for the fire fighting units (BG, VTS e SM models) according to UNI11292 norm.

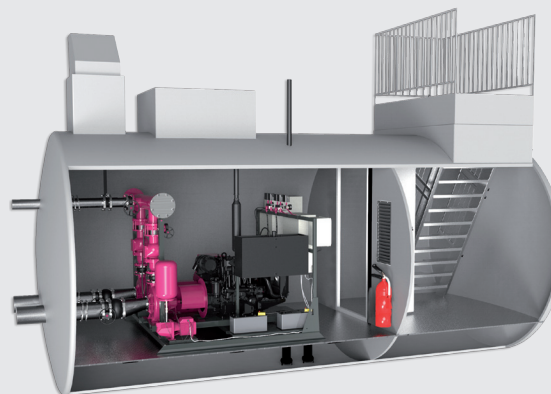

UNIVAIN: Locale tecnico da INTERRO a norma UNI11292 per alloggio gruppi pompe della gamma BG.
UNIVAIN: Underground room for the fire fighting units (BG models) according to UNI11292 norm.

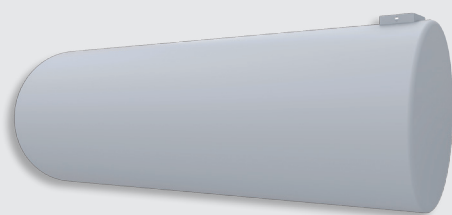

Riserve idriche per impianti antincendio da interro o da esterno, nella versione in acciaio o in polietilene.
Polyethylen and steel water storage for underground and external fire fighting units.

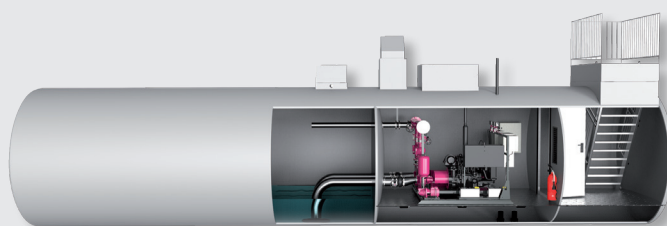

Sistemi integrati da interro o da esterno a norma UNI11292.
Underground and externa integrated systems accordin to UNI11292 norm.

Per tutte le informazioni consultare la sezione dedicata del nostro catalogo.
For any information please look at appropriate catalogue.





CATALOGO SISTEMI ANTINCENDIO UNI EN 12845
UNI EN 12845 FIRE FIGHTING SYSTEMS CATALOGUE



CATALOGO LOCALI TECNICI E SISTEMI INTEGRATI UNI 11292
PER GRUPPI ANTINCENDIO
UNI 11292 TECHNICAL PREMISES AND INTEGRATED SYSTEMS
FOR FIRE FIGHTING UNITS CATALOGUE



CATALOGO GRUPPI DI PRESSURIZZAZIONE
PRESSURIZATION UNITS CATALOGUE

MEMBER OF



CATALOGO TECNICO TECHNICAL CATALOGUE



IDROFOGLIA srl

Via Provinciale, 14 / 61026 Lunano (PU) Italy
phone +39 0722.700311 / fax +39 0722.700309
www.idrofogliasafety.com / staff@idrofoglia.com



MADE IN ITALY